

# ELITE 350B180

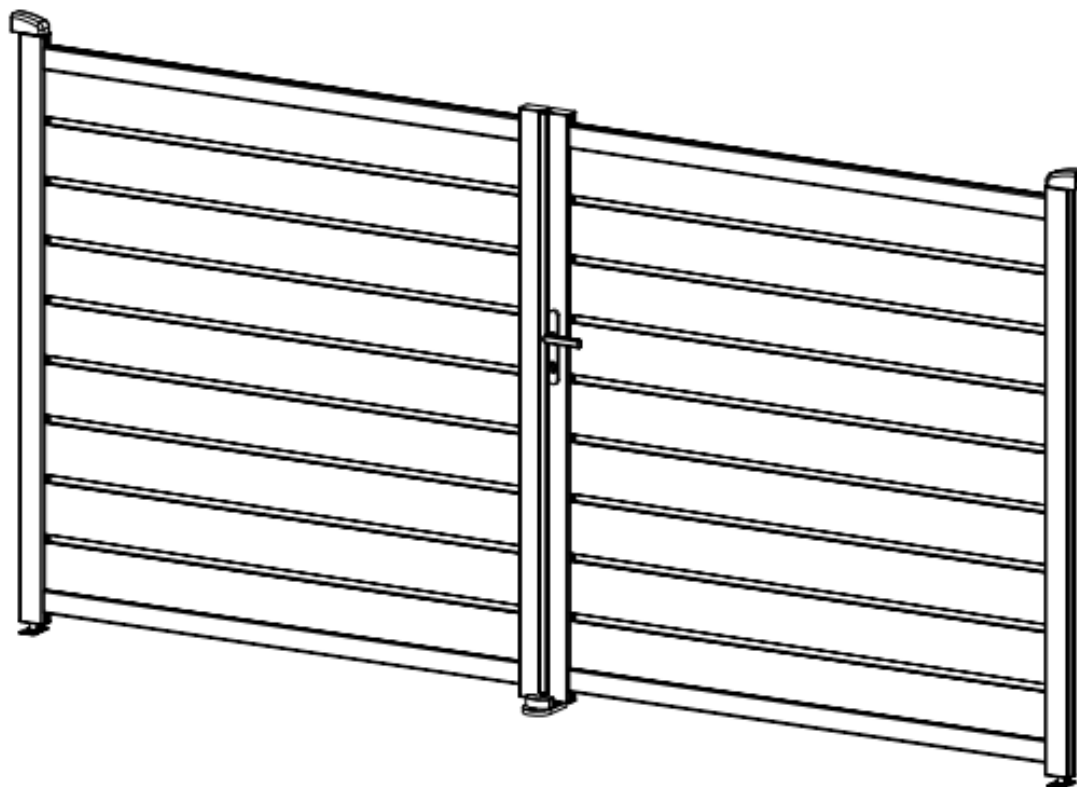

Manual de instrucciones

CE



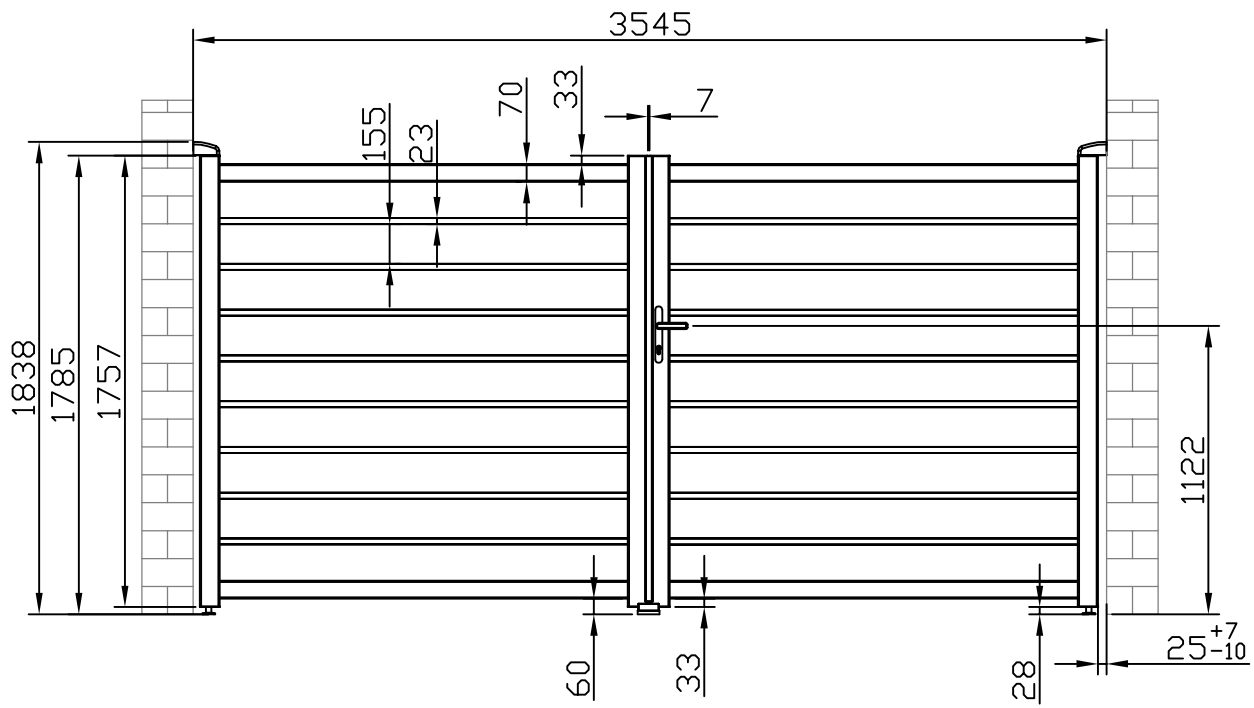

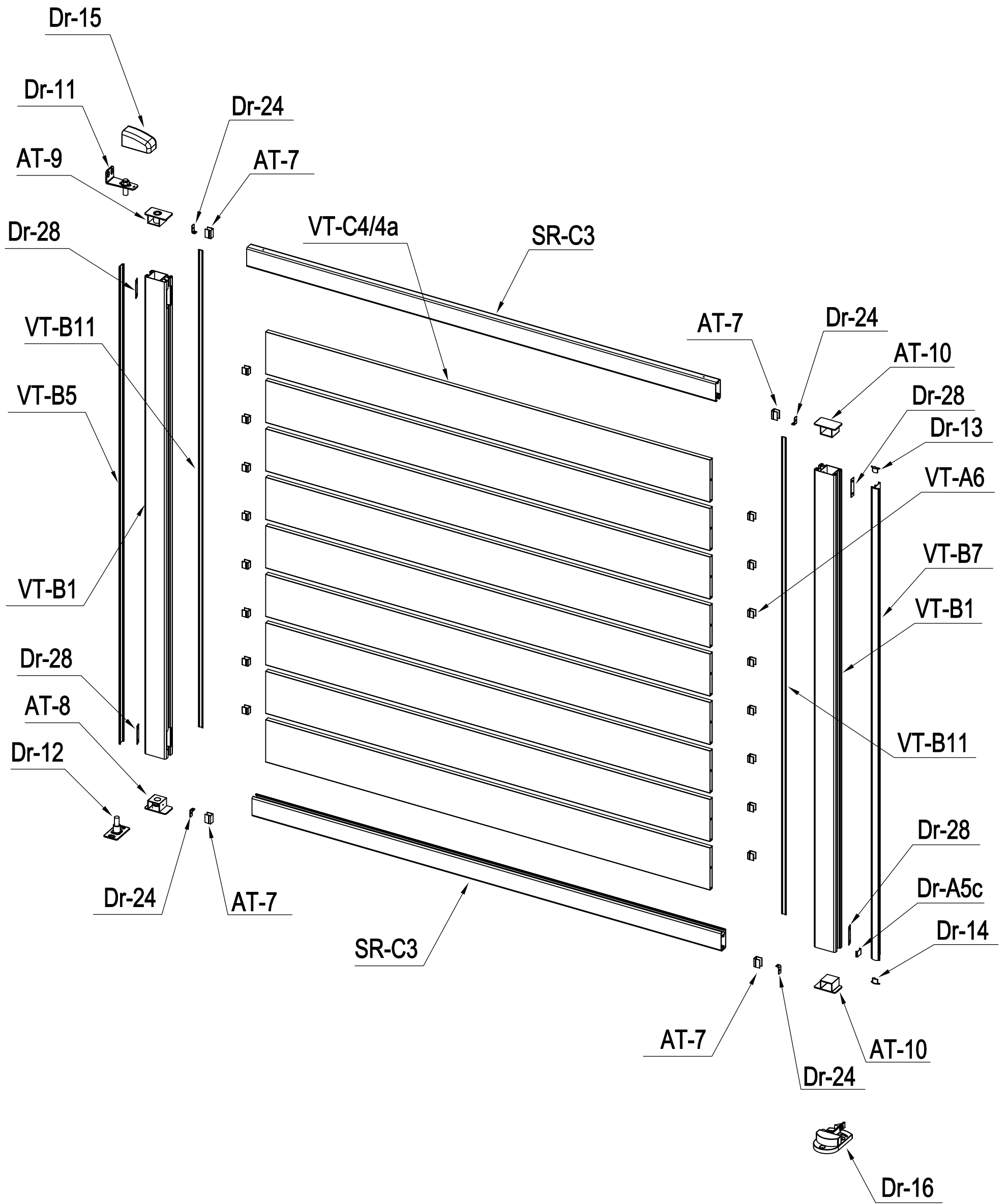

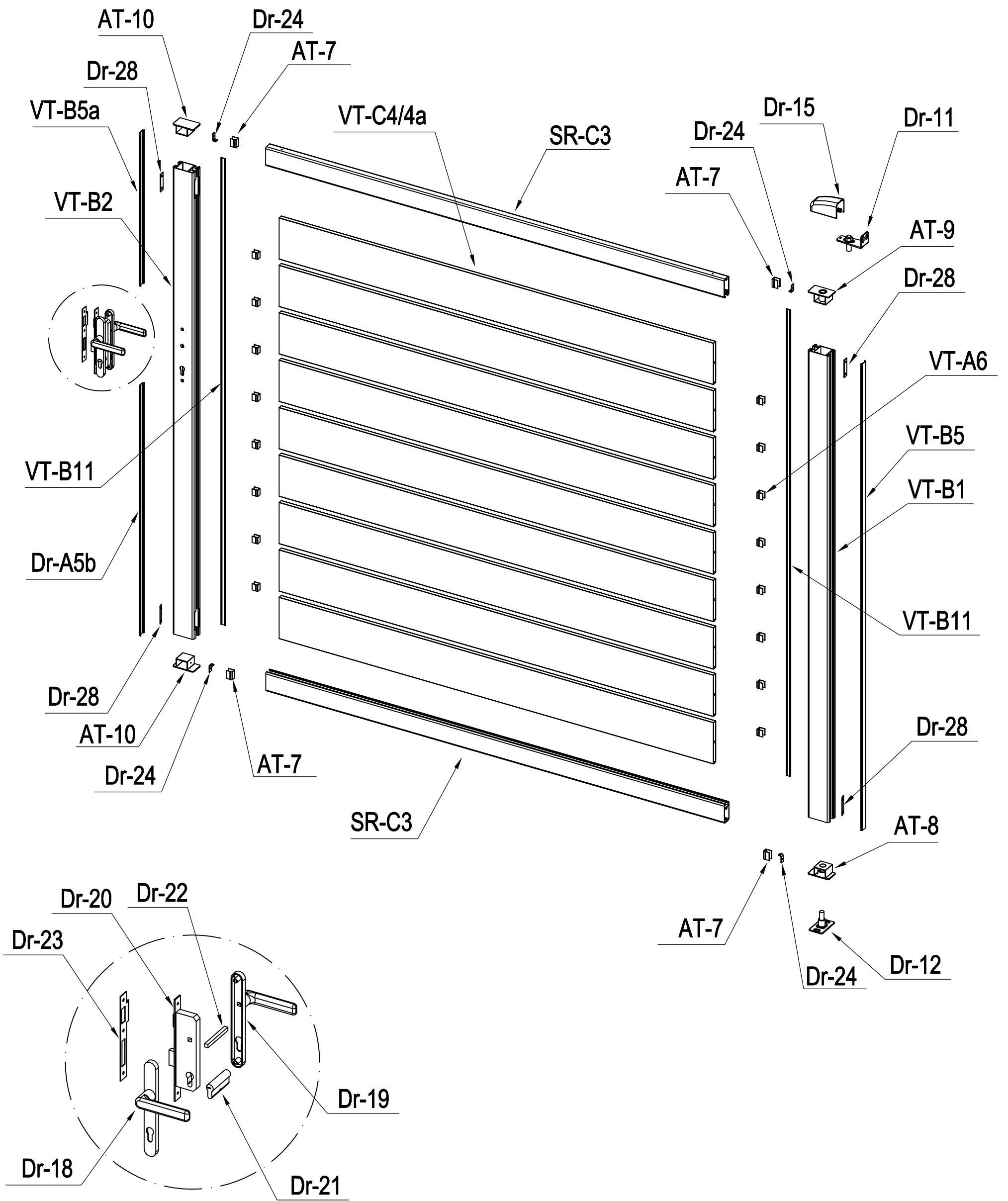



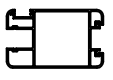
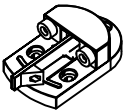



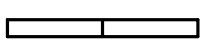
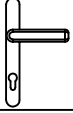

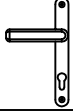
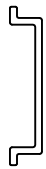



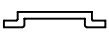
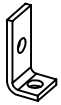





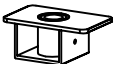



**motic**



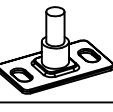
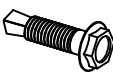



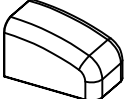

# PART LIST

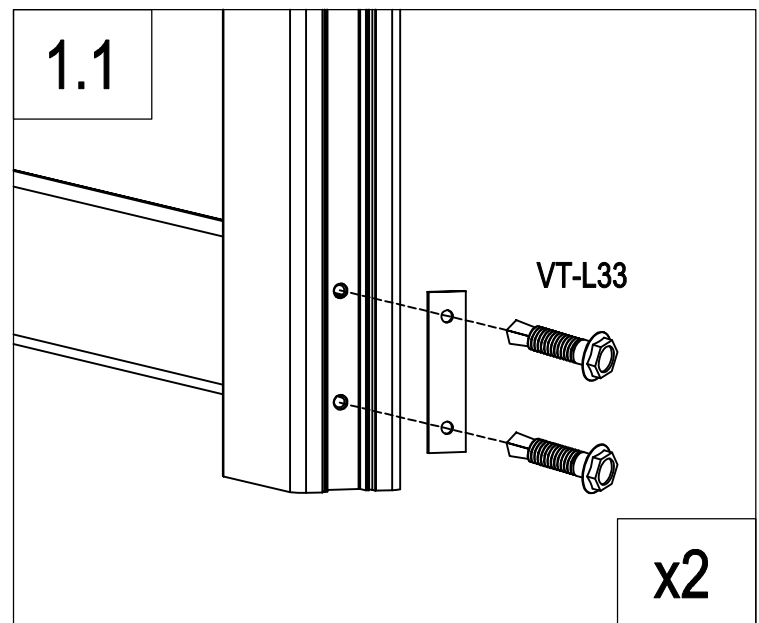
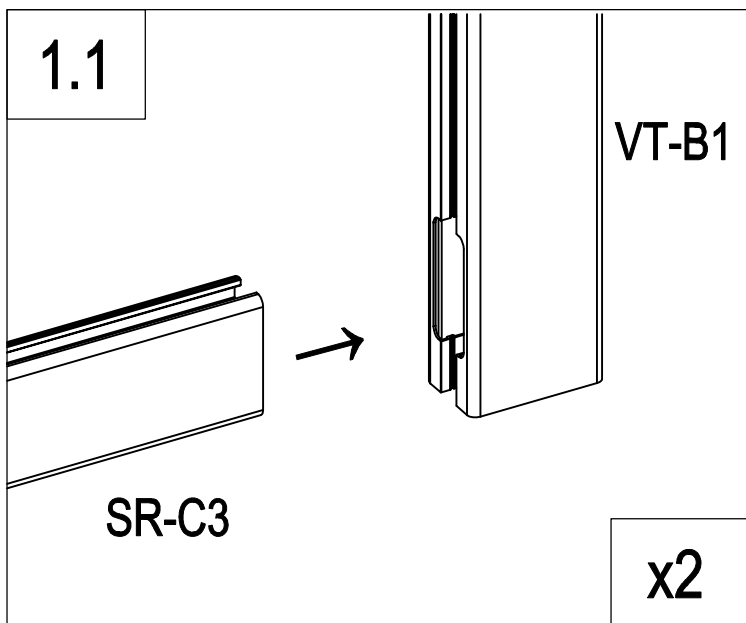
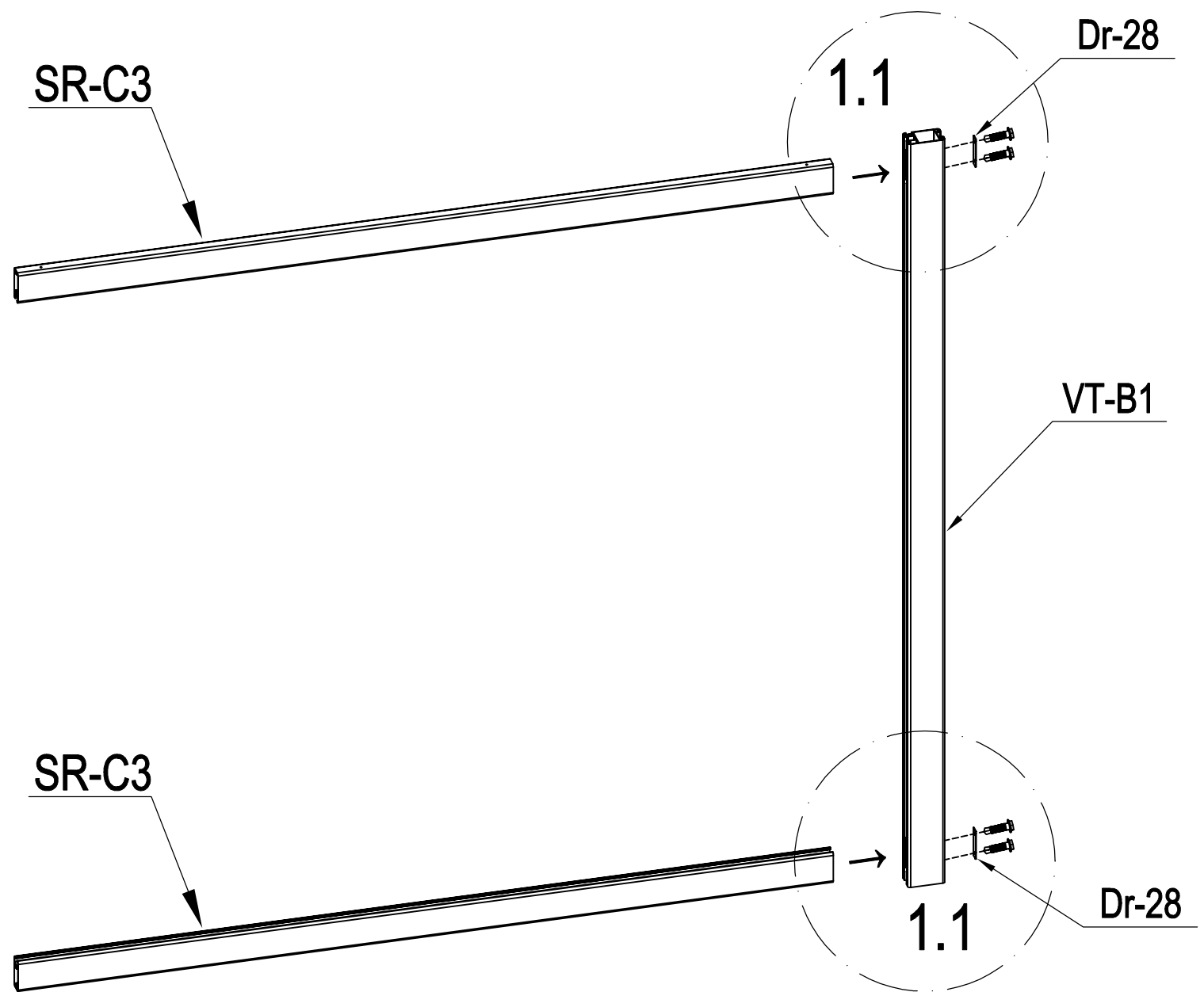
IMAGE	NO.	L.(mm)	QTY	IMAGE	NO.	L.(mm)	QTY
	VT-B1	1751	3		Dr-16		1
	VT-B2	1751	1			Dr-17	
	SR-C3	1721	4			Dr-31	
	VT-C4	1630	16		Dr-18		1
	VT-C4a (+SR-C15)	1630	2		Dr-19		1
	VT-B5	1751	2		Dr-20		1
	VT-B5a	573.5	1		Dr-21		1
	Dr-A5b	937	1		Dr-22		1
	Dr-A5c	19.5	1		Dr-23		1
	VT-B11	1751	4		Dr-24		8
	VT-A6	23	32		Dr-25		1
	AT-7	29.5	8		Dr-25a		2
	VT-B7	1731	1		Dr-26		3
	AT-8		2		Dr-27		2
	AT-9		2		VT-L30		8
	AT-10		4		VT-L31		8
	Dr-11		2		VT-L32		12
	Dr-12		2		VT-L33		16
	Dr-13		1		VT-L34		3
	Dr-14		1		VT-L35		3
	Dr-15		2		VT-L36		72
					Dr-28		8

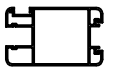
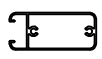

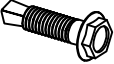
	VT-B1	1
	SR-C3	2
	Dr-28	2
	VT-L33	4

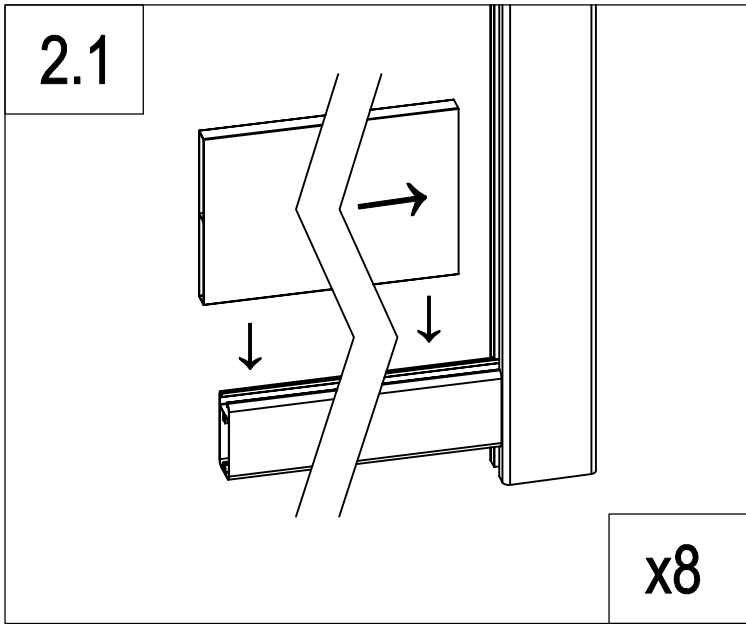
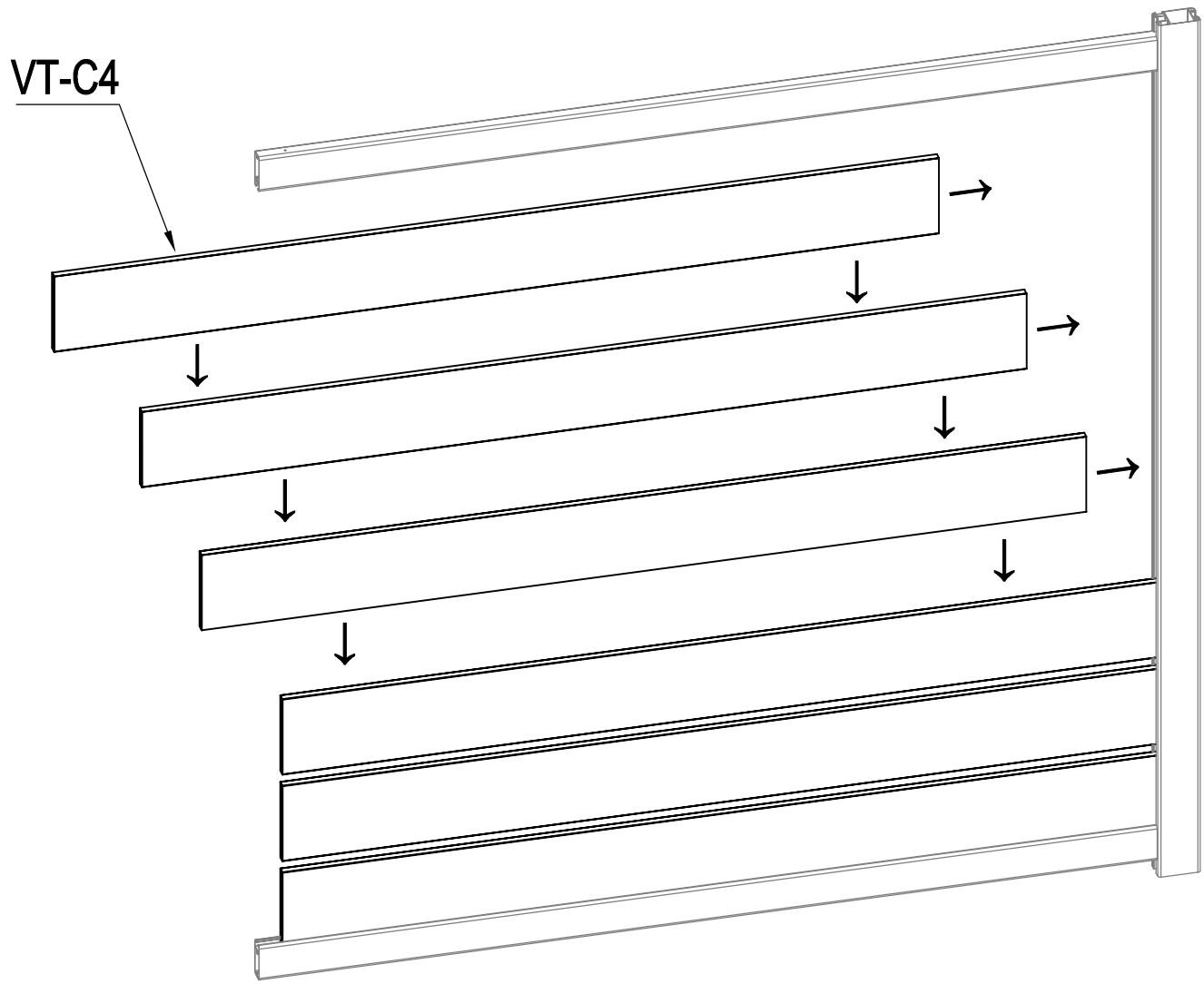

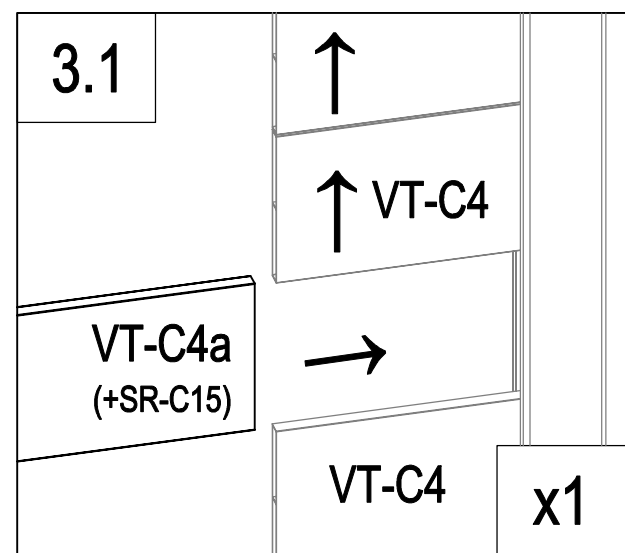
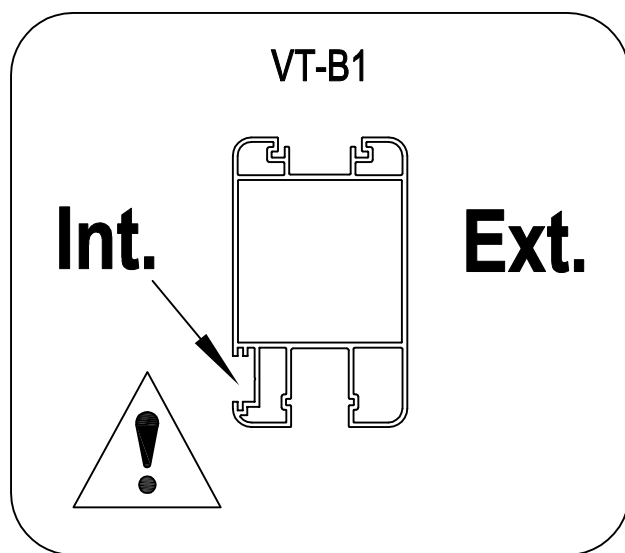
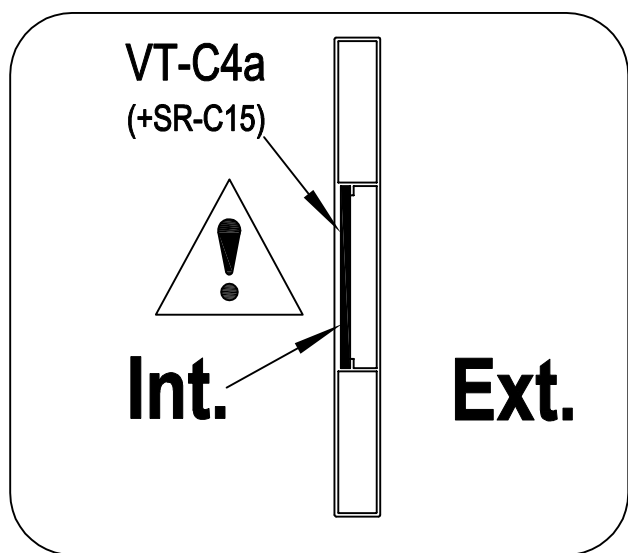
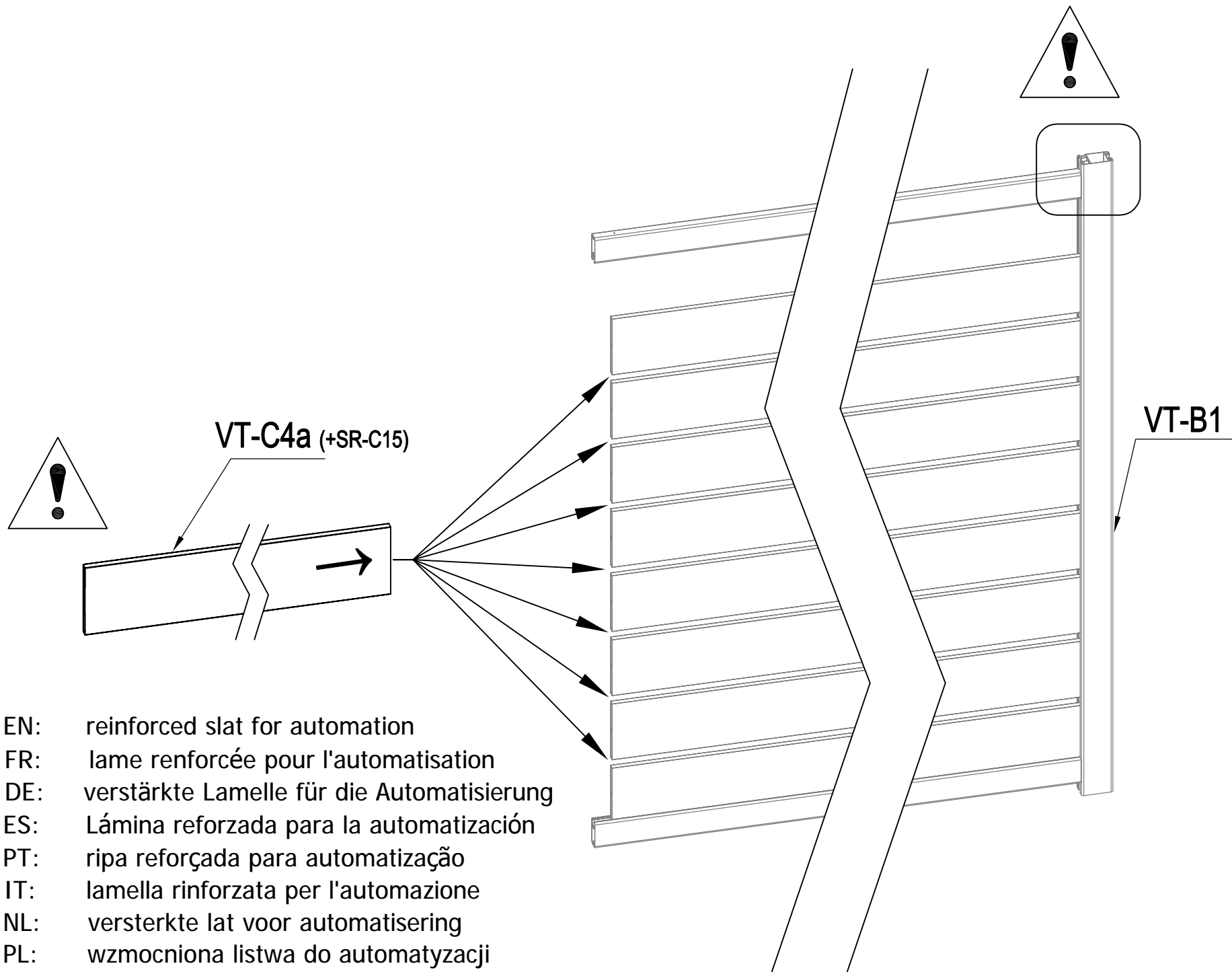

	VT-C4	8
---	-------	---

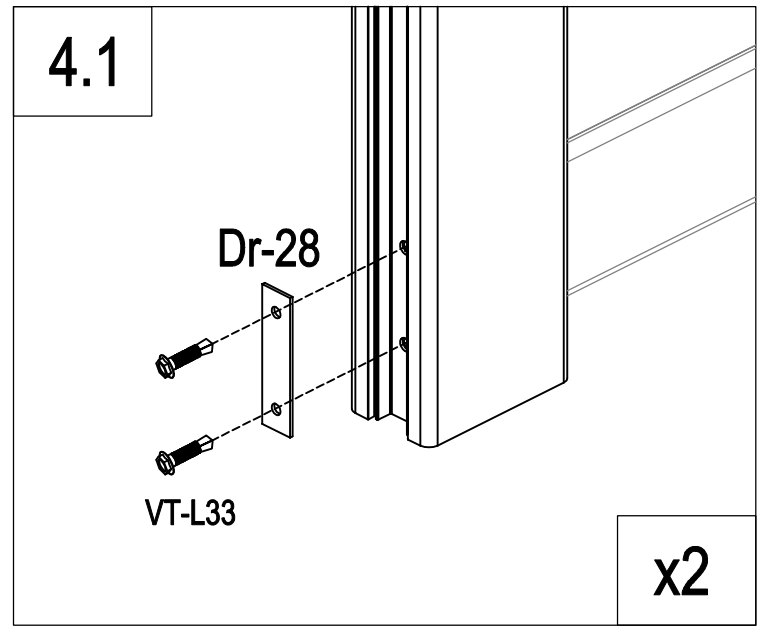
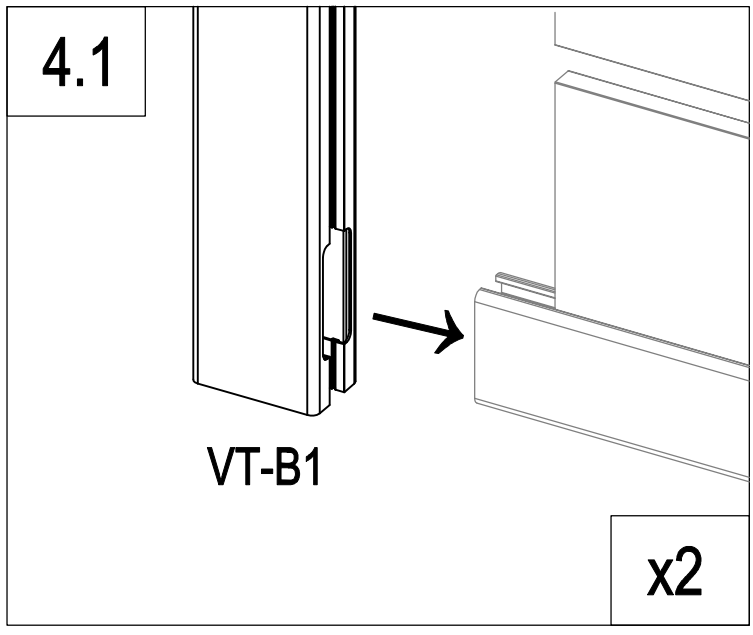
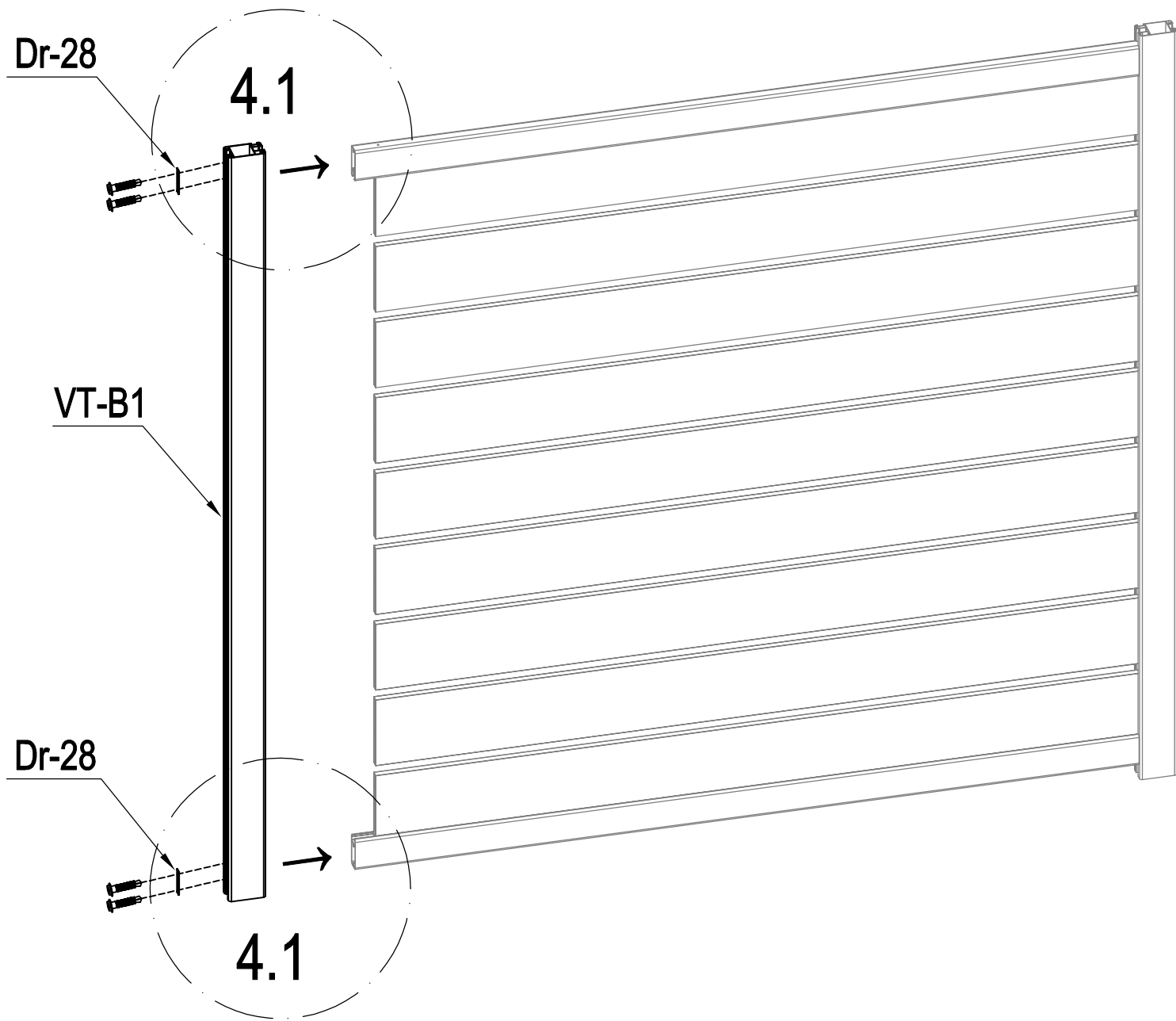

	VT-C4a (+SR-C15)	1
--	------------------	---

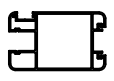

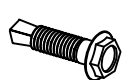
	VT-B1	1
	Dr-28	2
	VT-L33	4

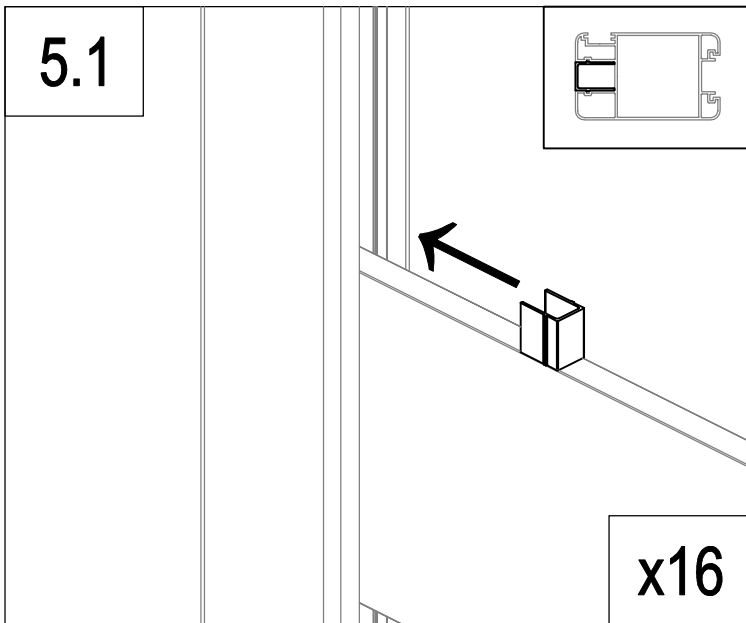
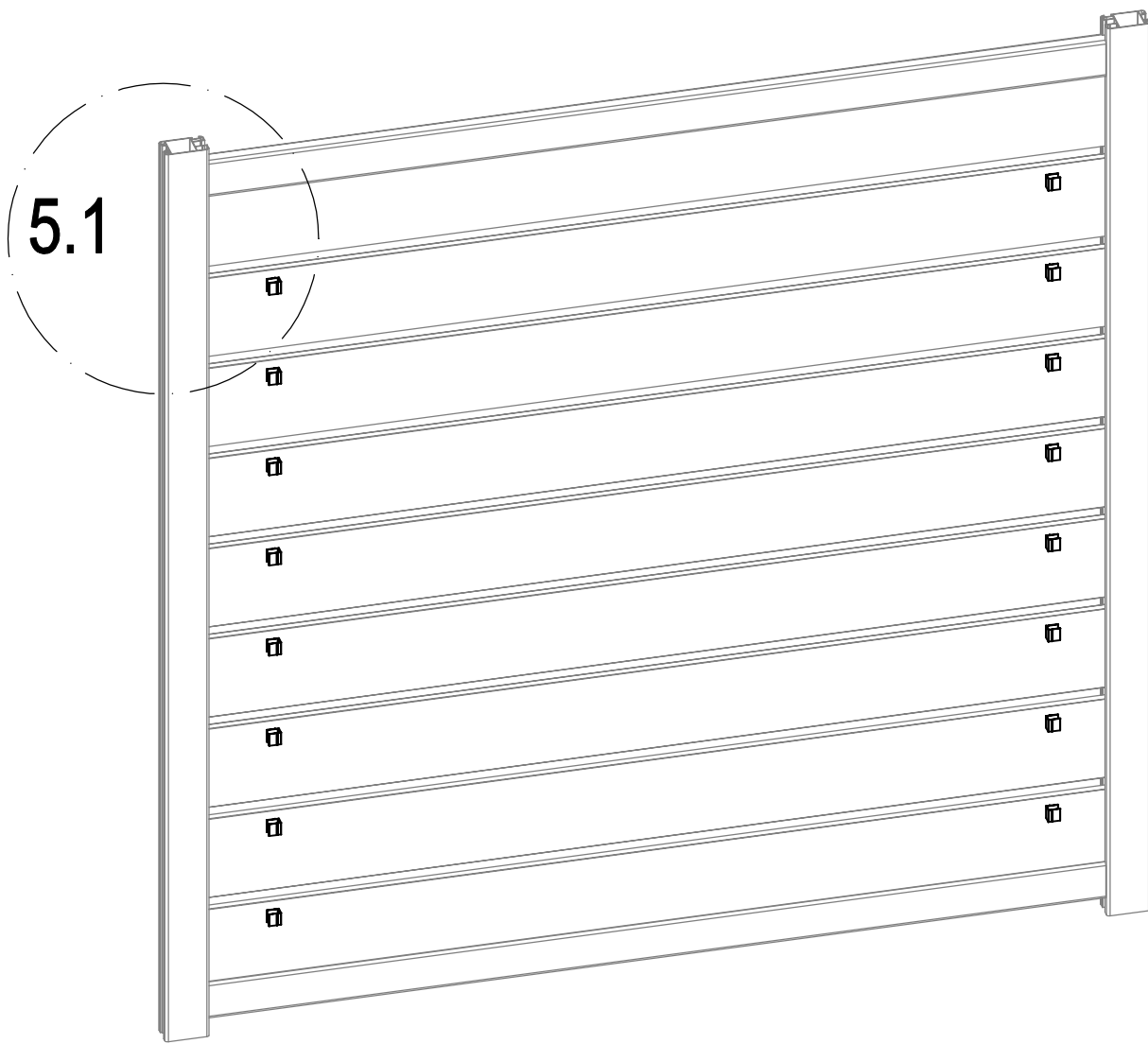

	VT-A6	16
---	-------	----

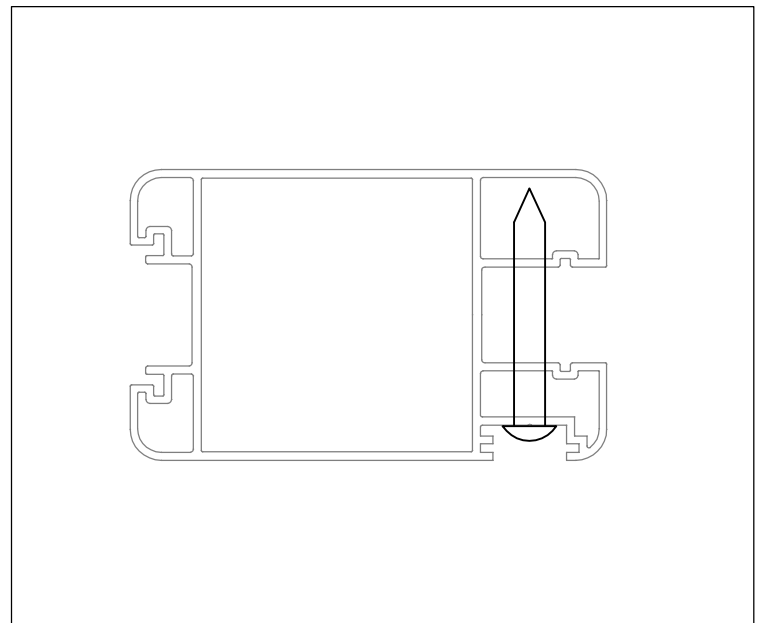
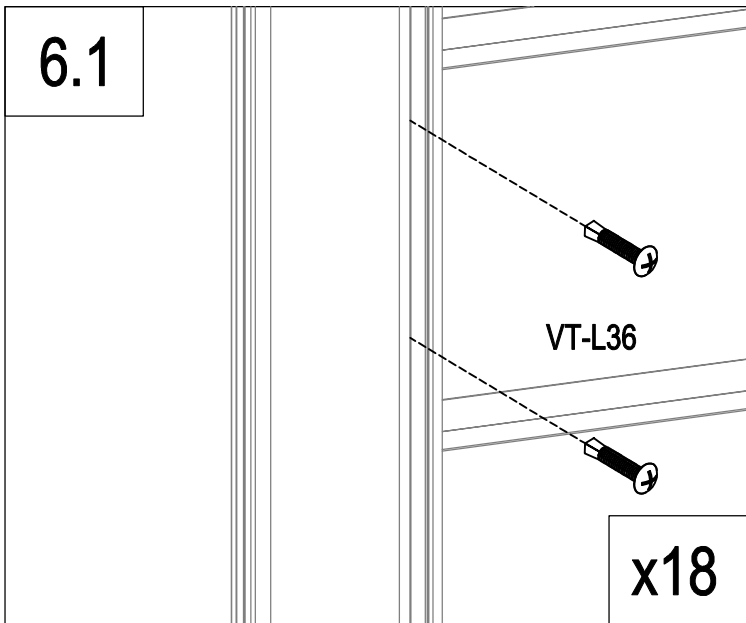
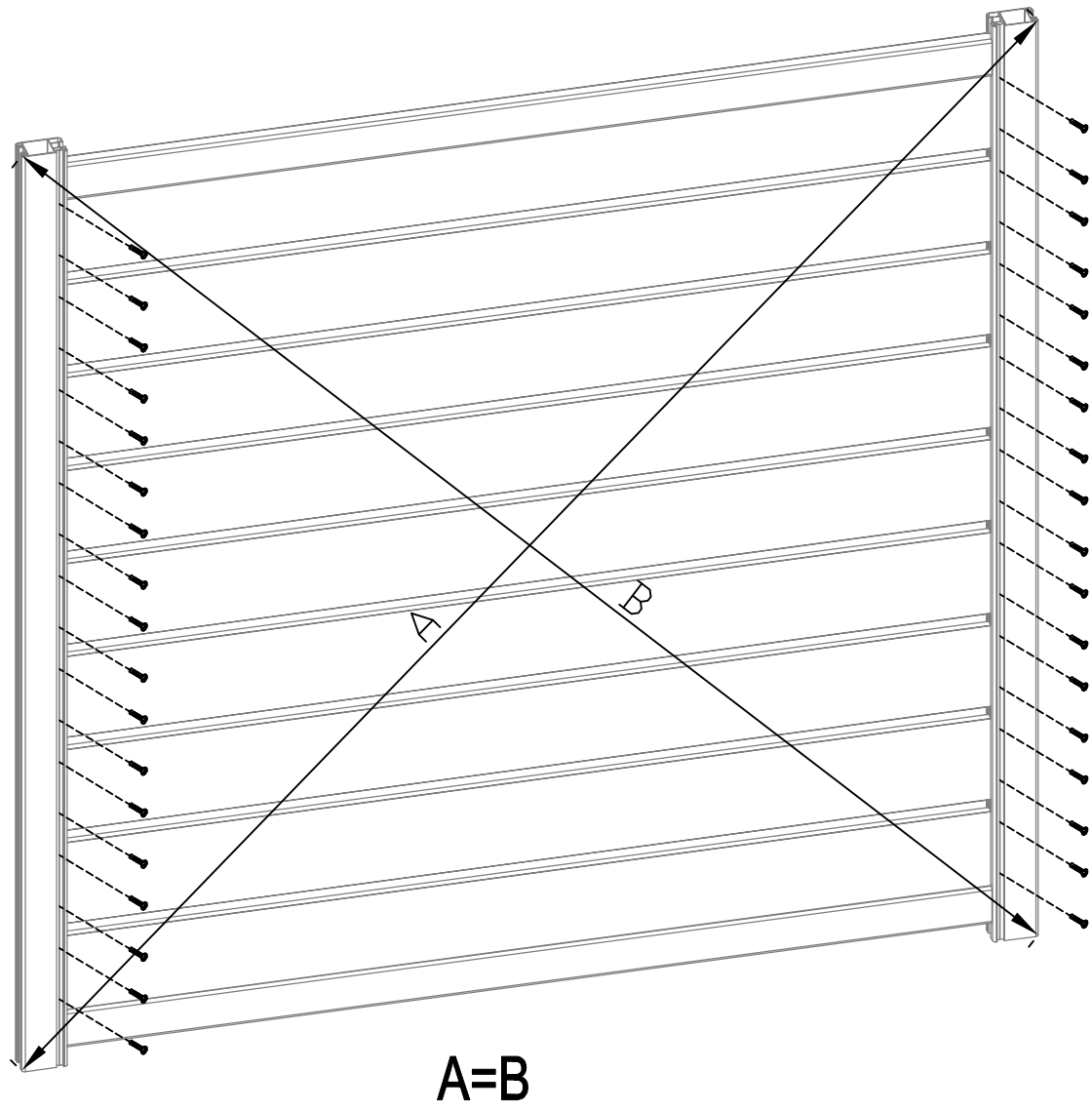
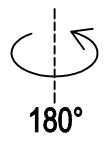

	VT-L36	36
--	--------	----

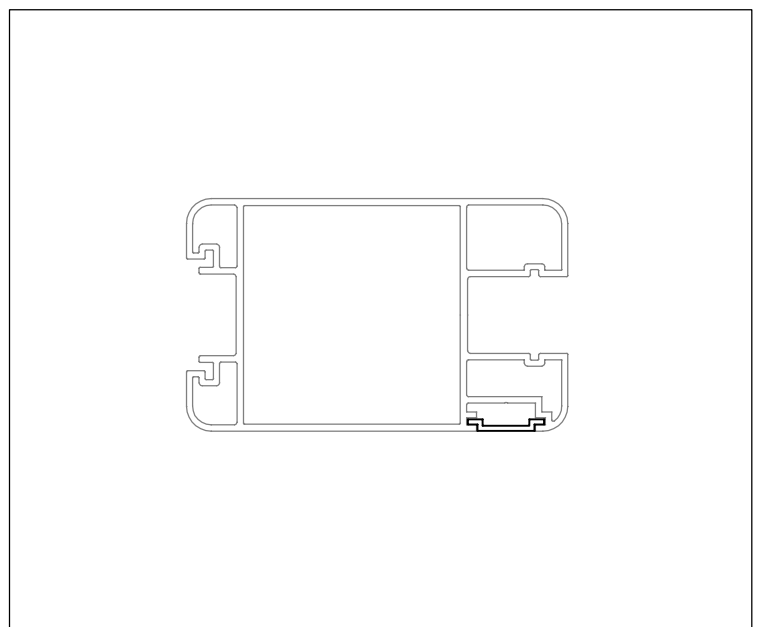
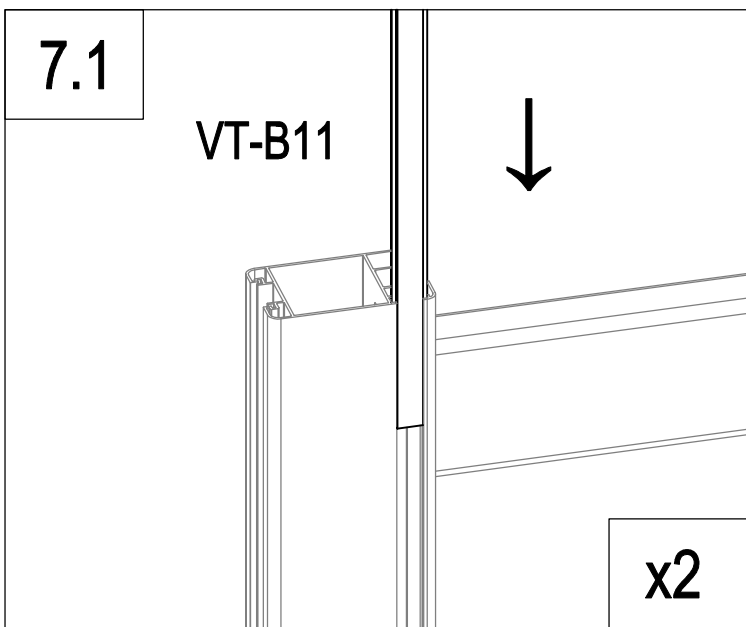
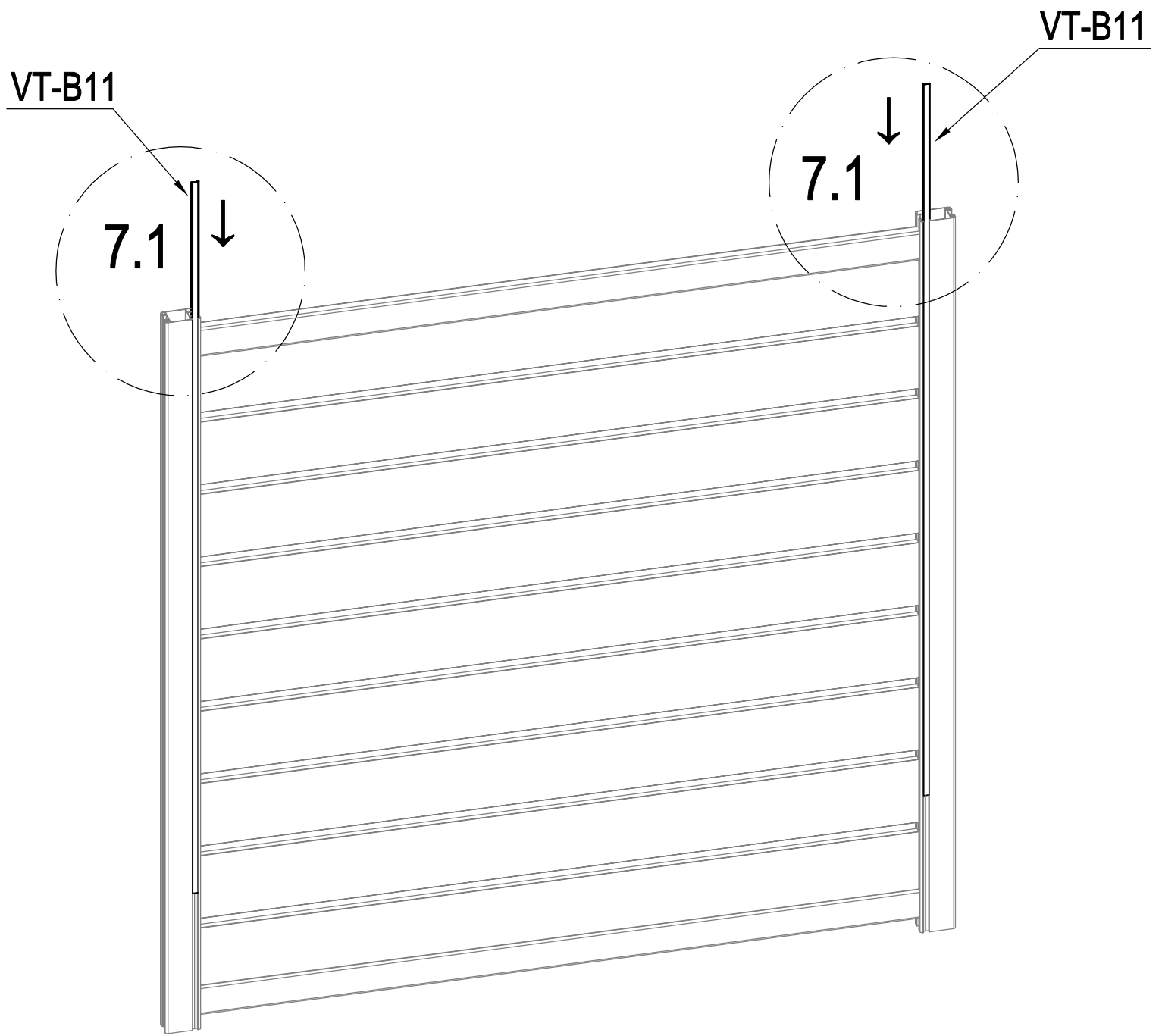

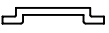
	VT-B11	2
---	--------	---

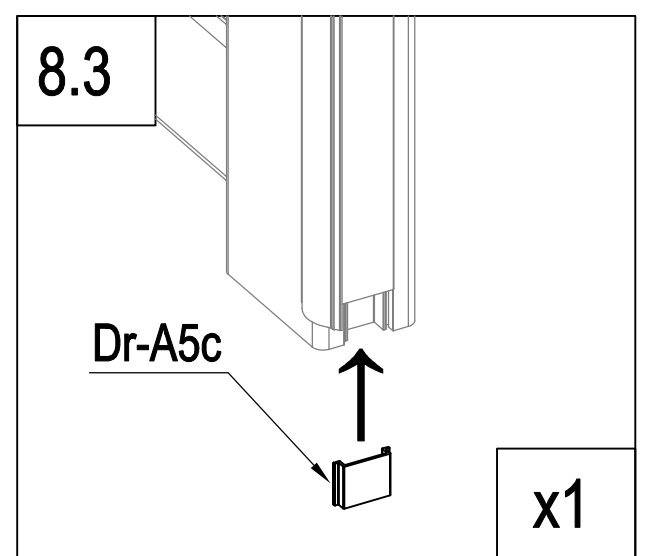
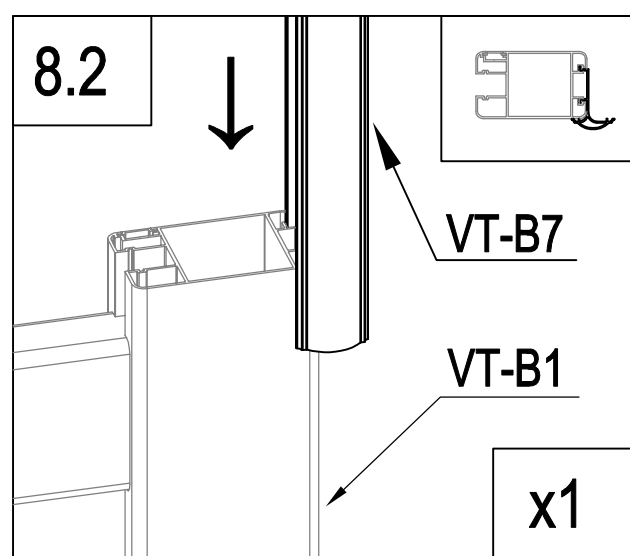
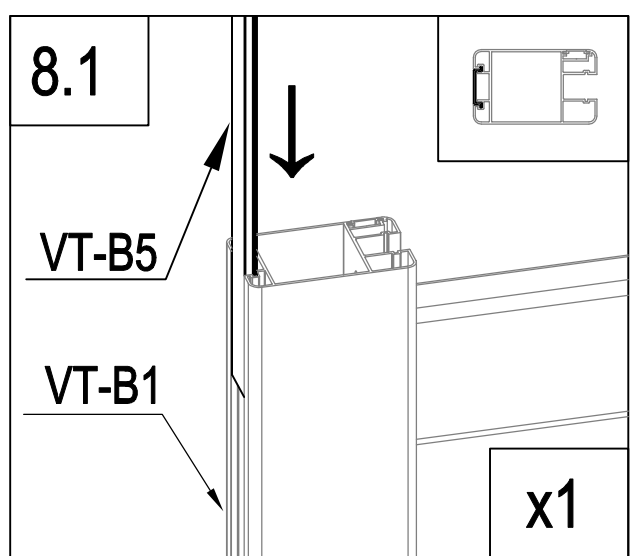
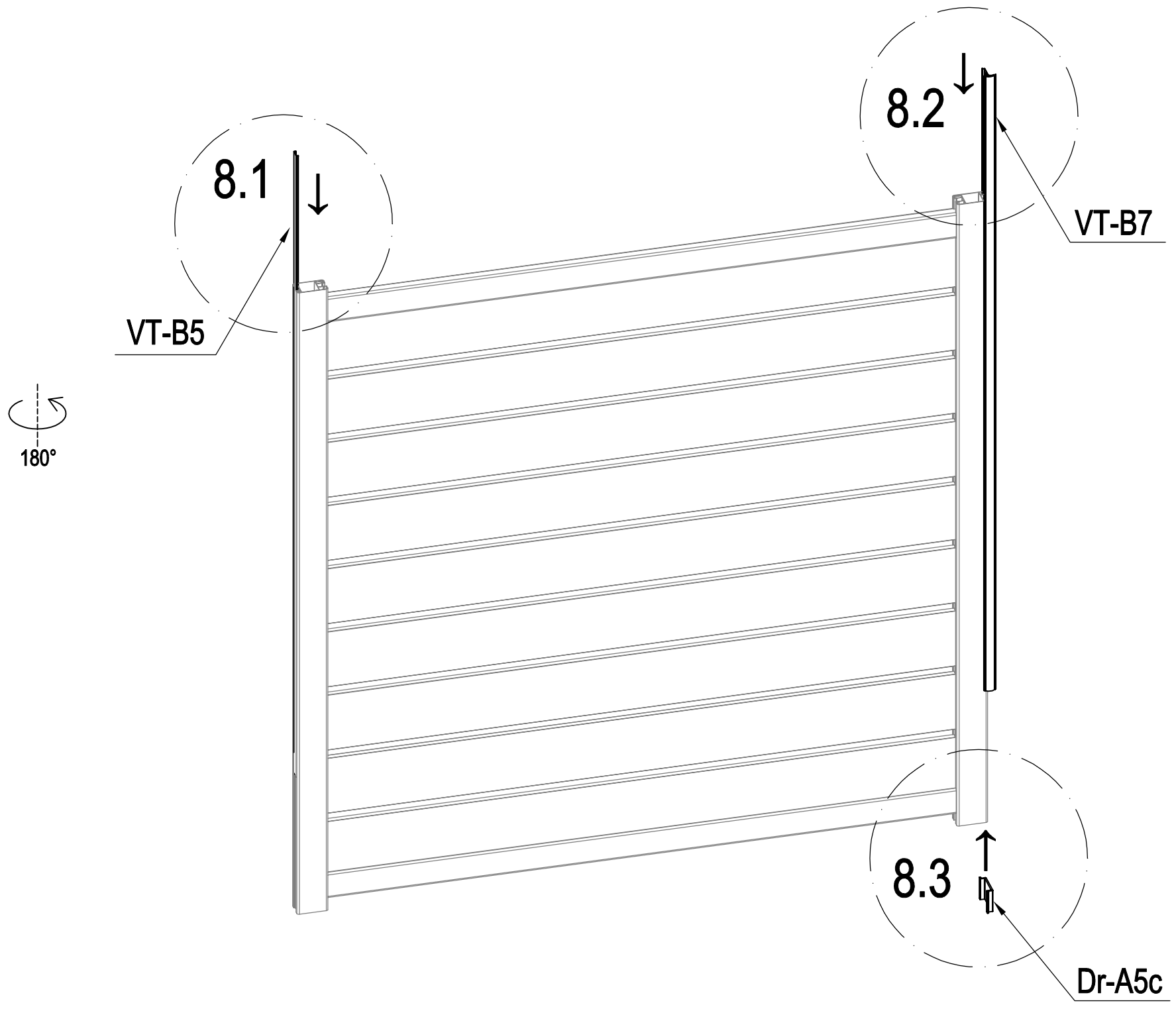

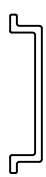
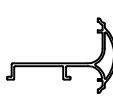
	VT-B5	1
	Dr-A5c	1
	VT-B7	1

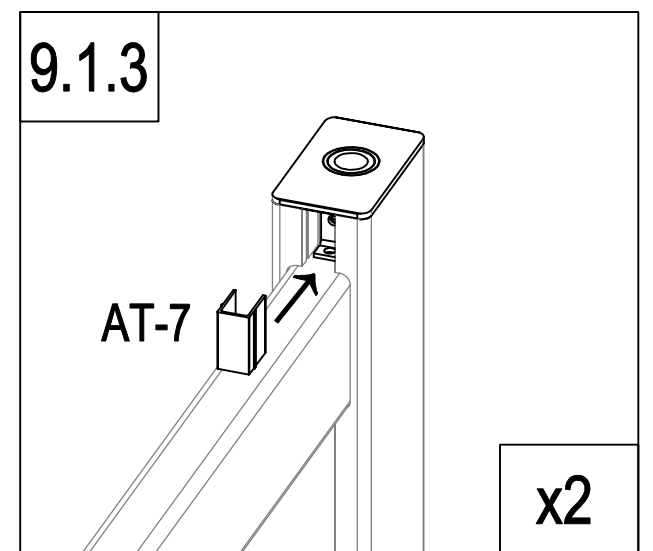
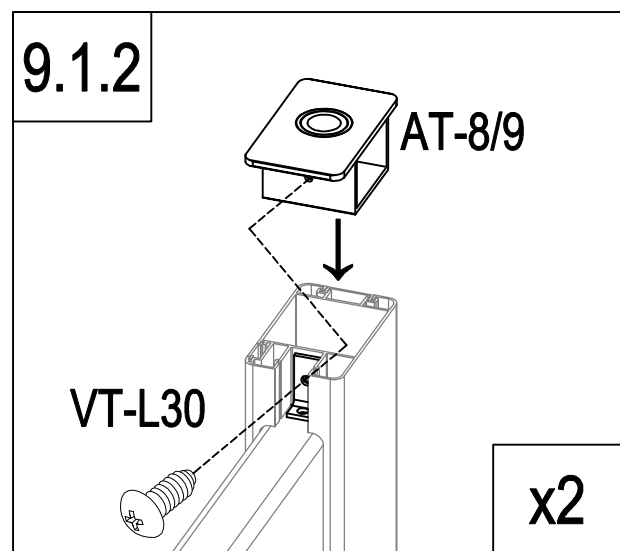
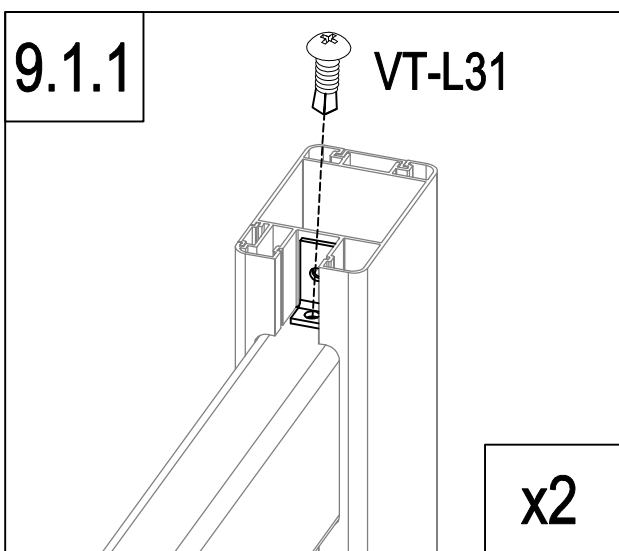
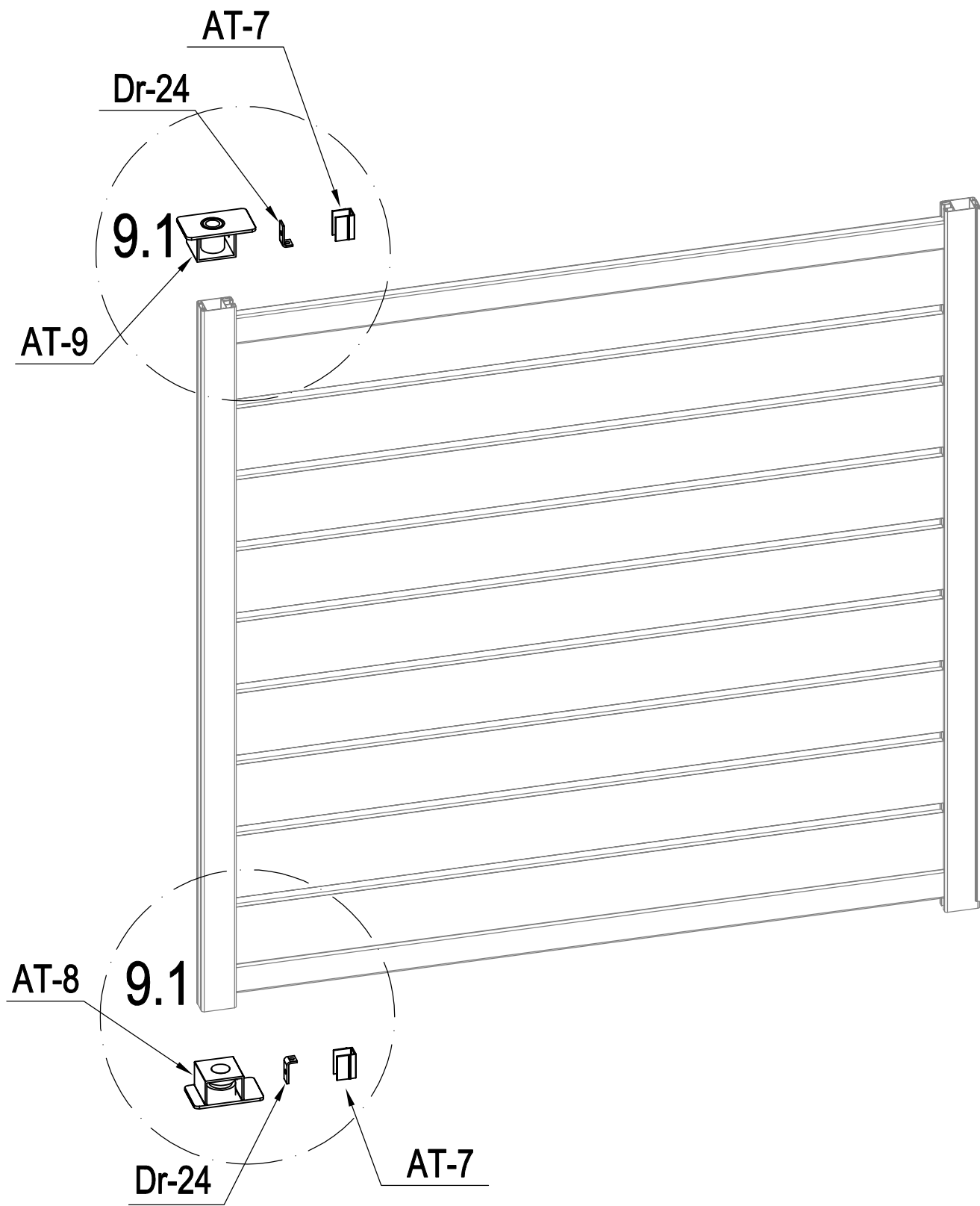

	AT-8	1
	AT-9	1
	Dr-24	2

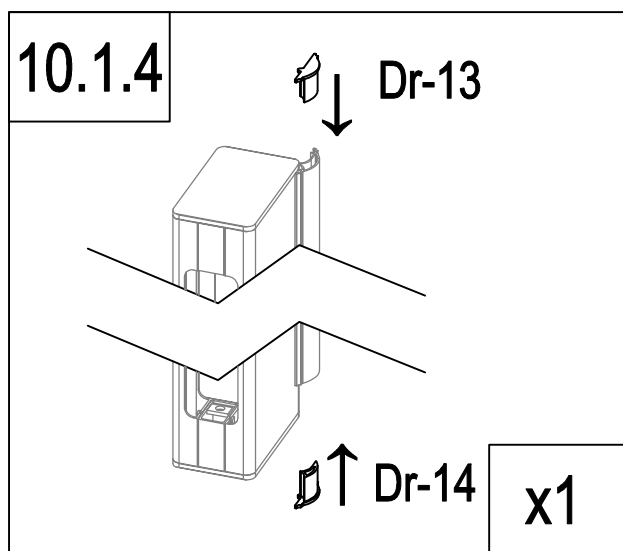
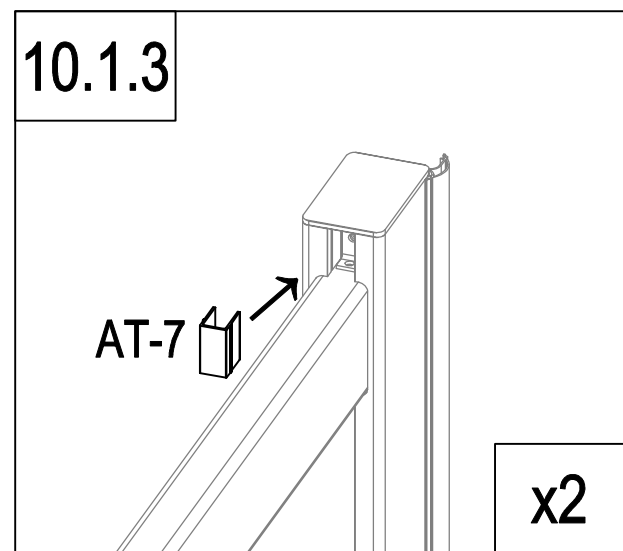
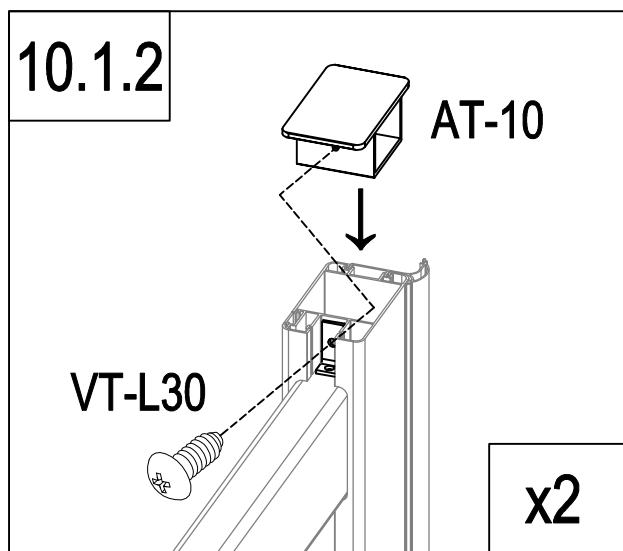
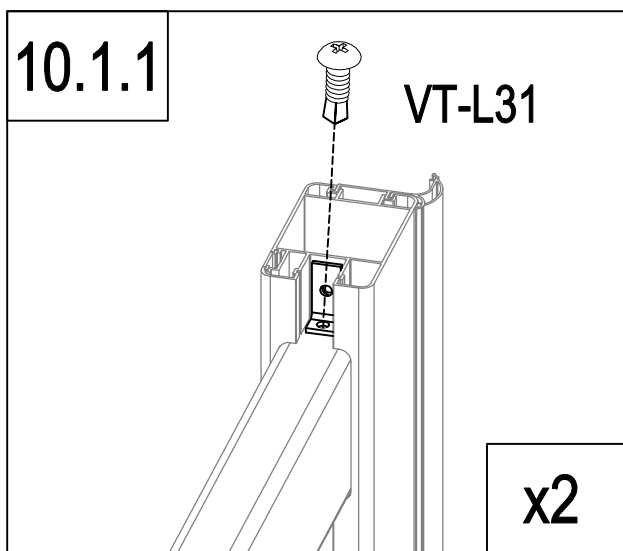
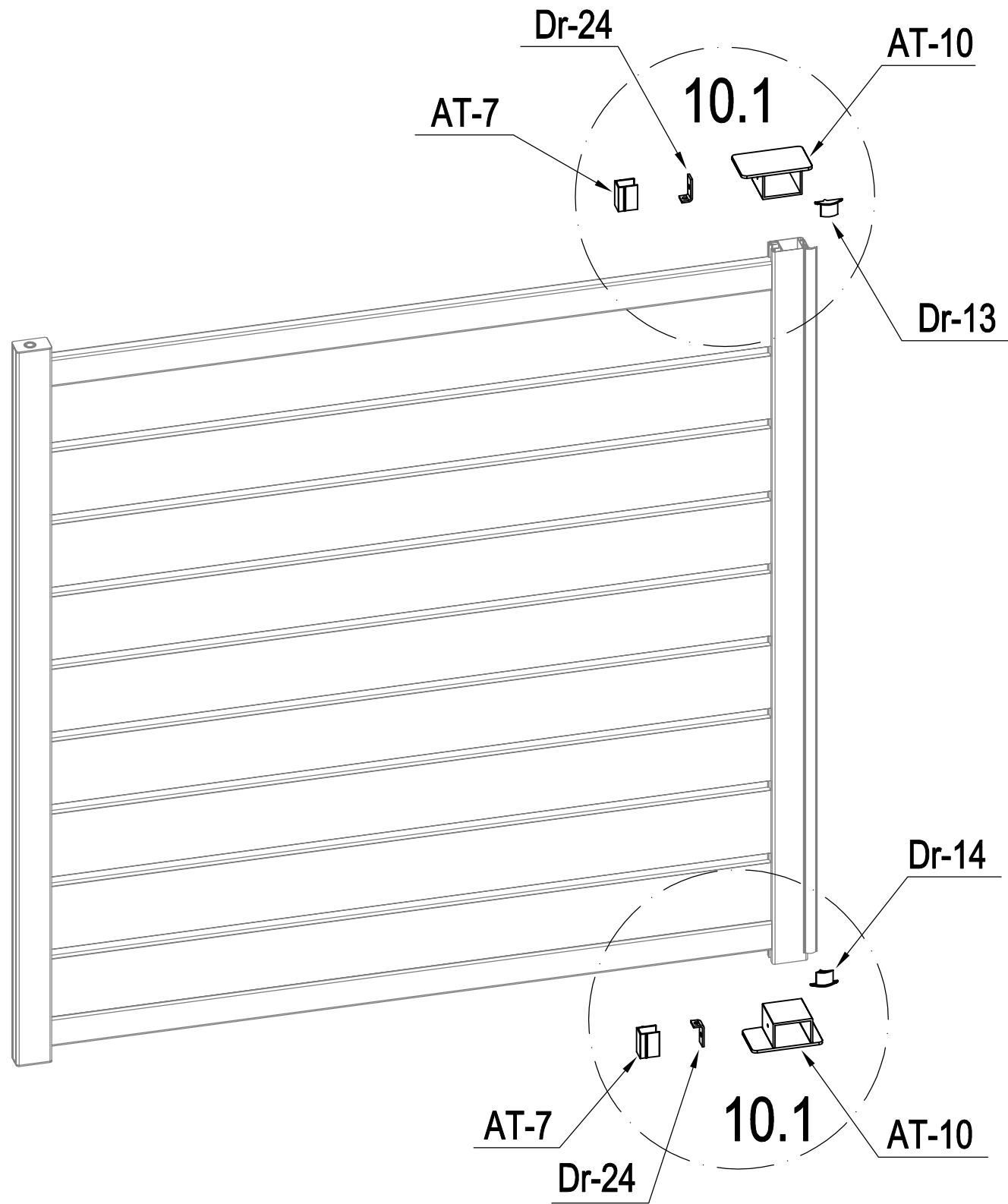

	AT-7	2
	VT-L30	2
	VT-L31	2



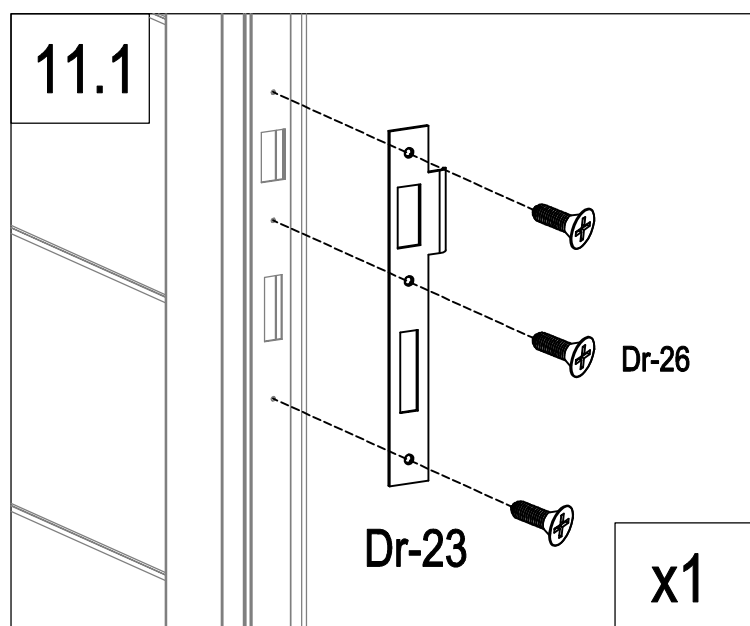
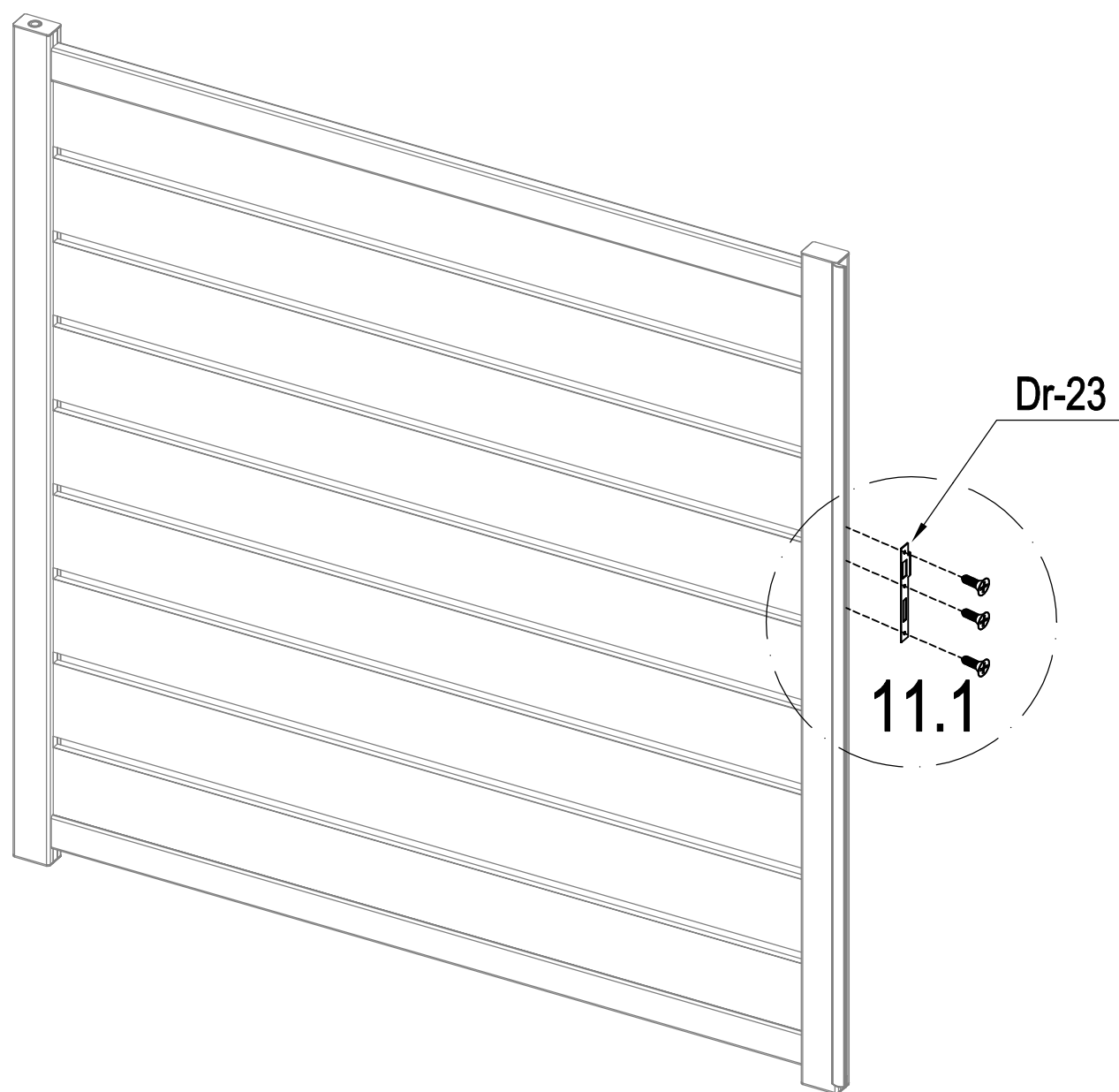

	AT-10	2
	Dr-24	2
	AT-7	2
	Dr-13	1

	Dr-14	1
	VT-L30	2
	VT-L31	2

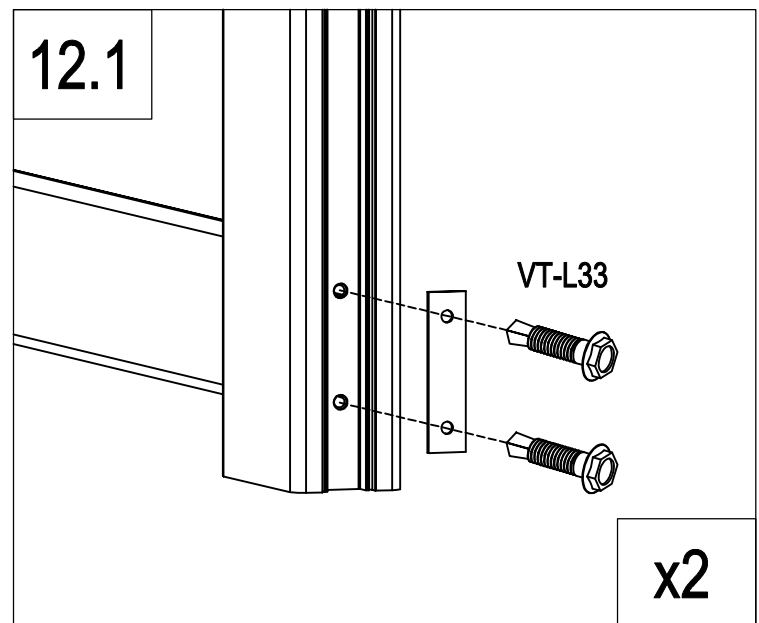
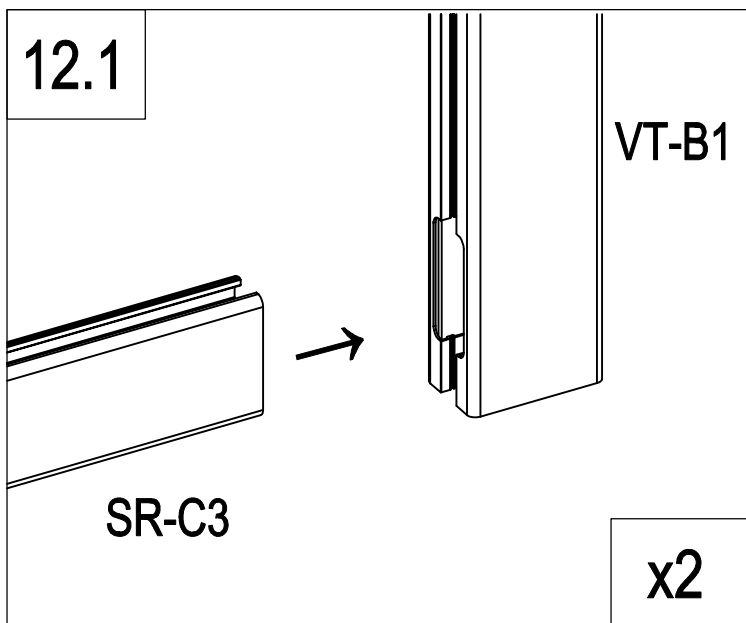
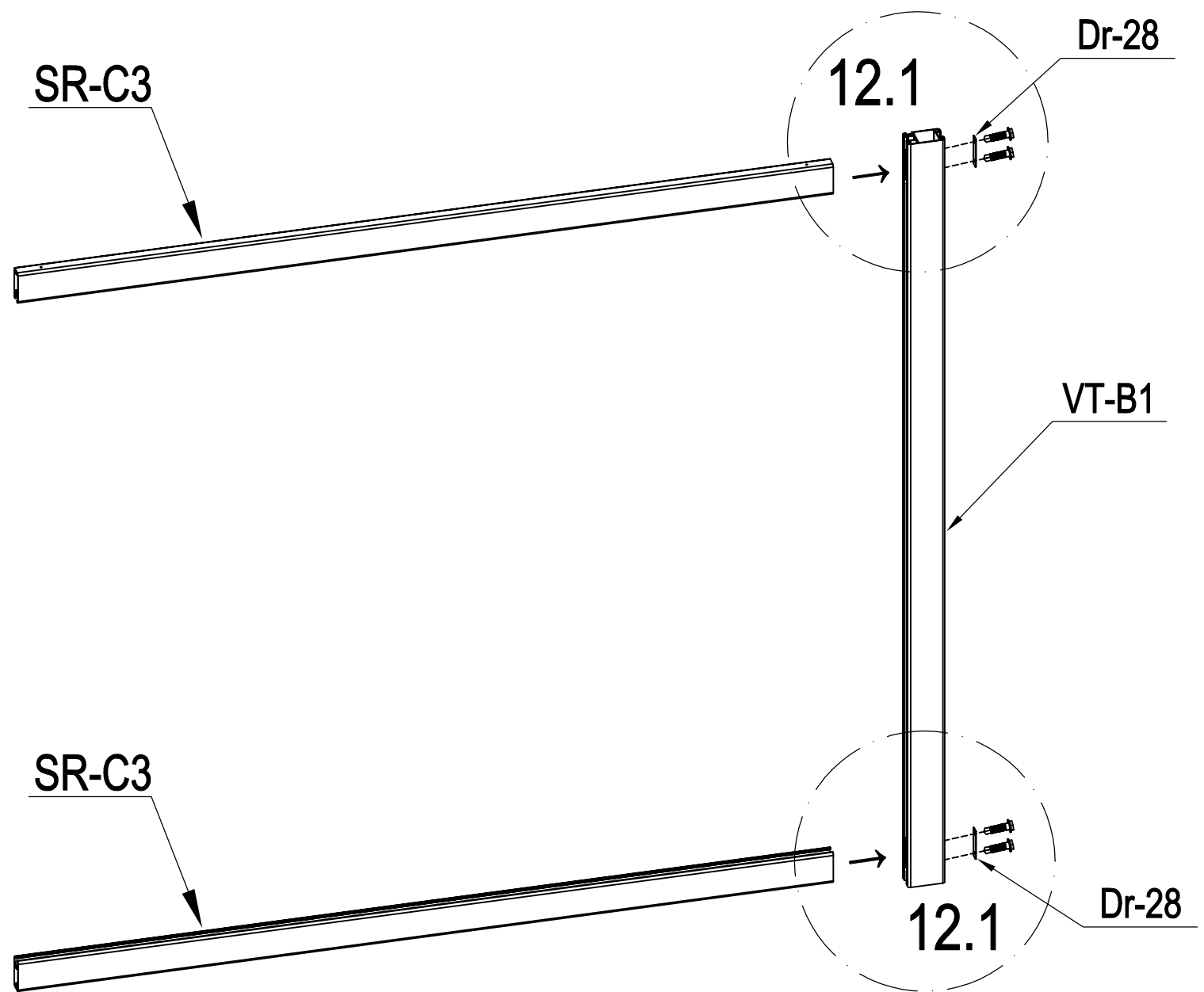

	Dr-23	1
	Dr-26	3

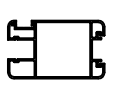
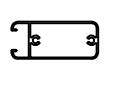

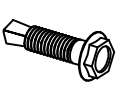
	VT-B1	1
	SR-C3	2
	Dr-28	2
	VT-L33	4

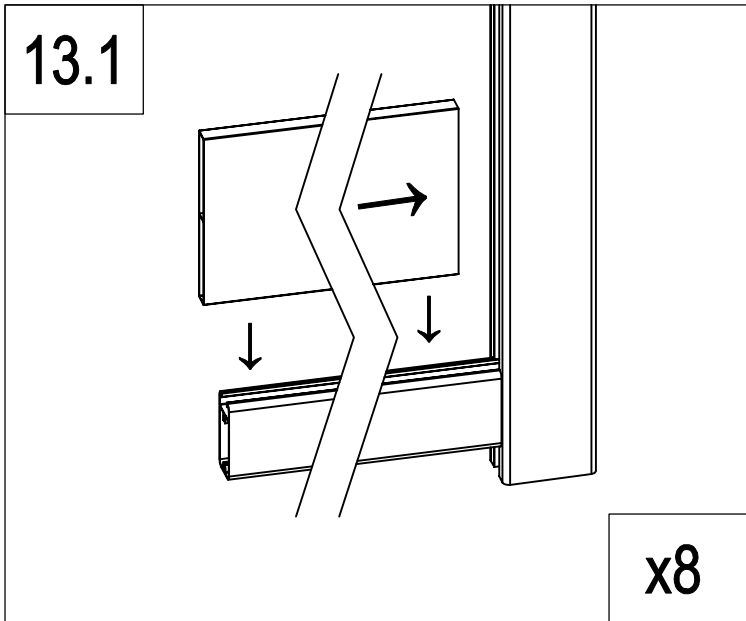
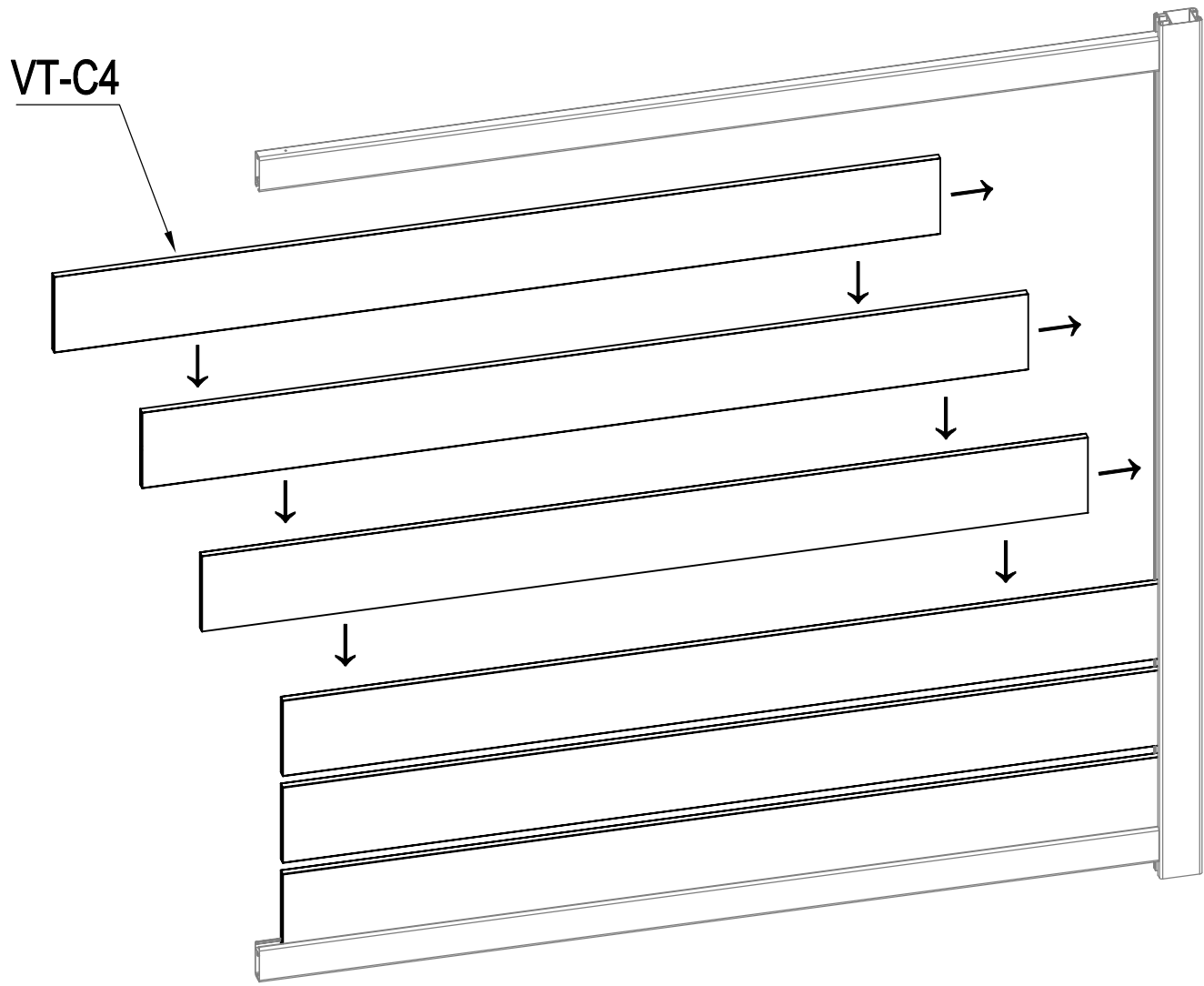

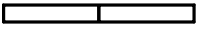

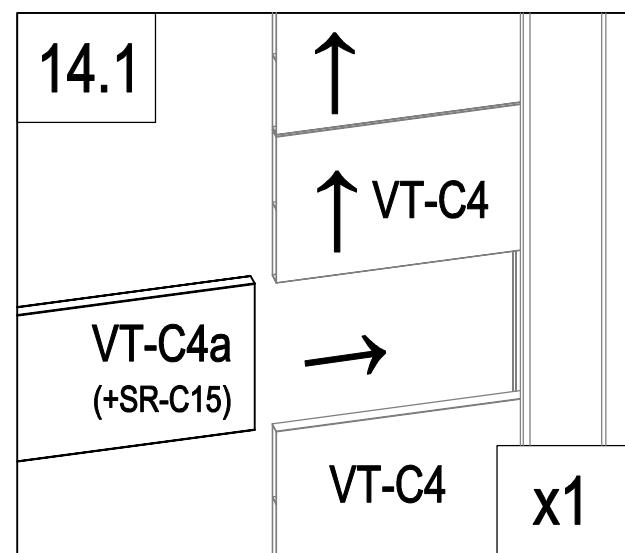
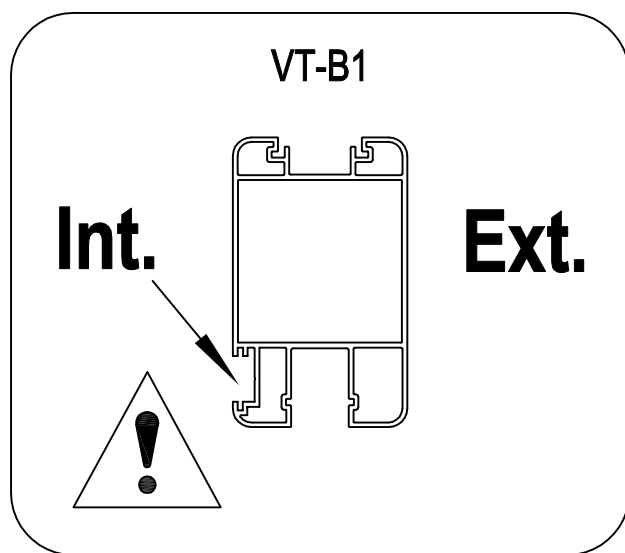
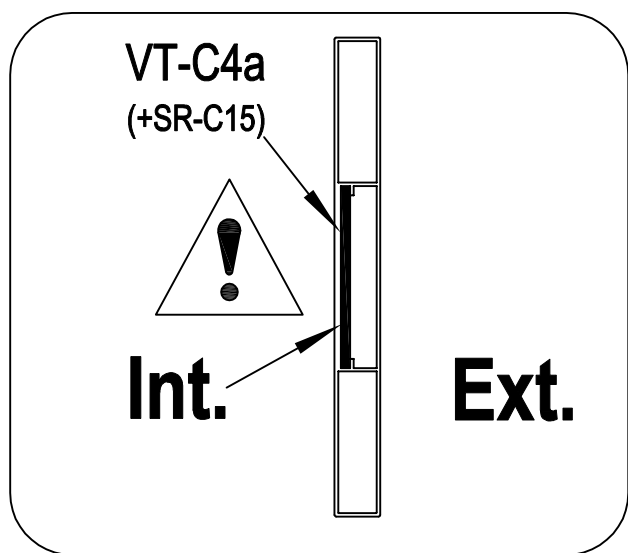
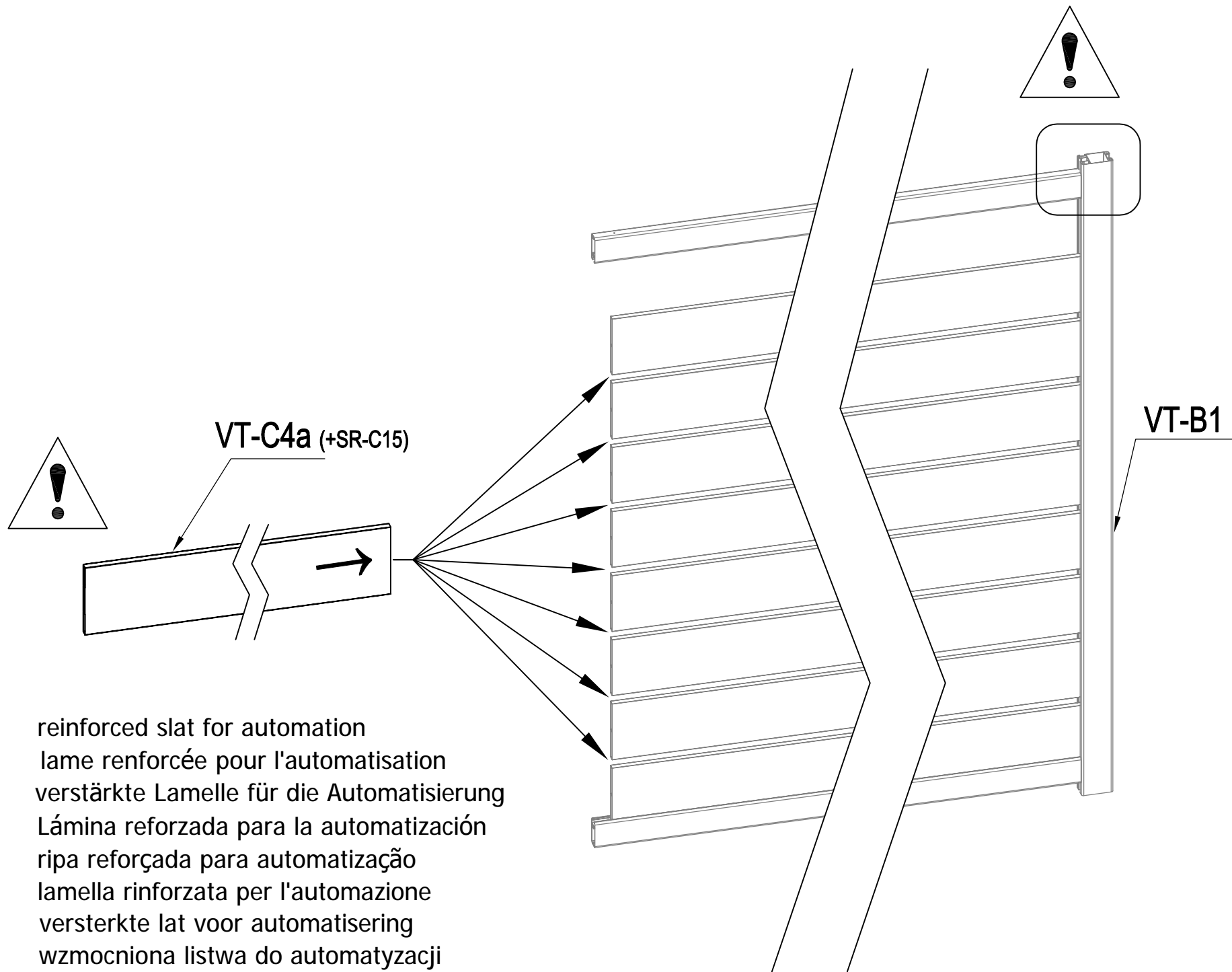
	VT-C4	8
---	-------	---

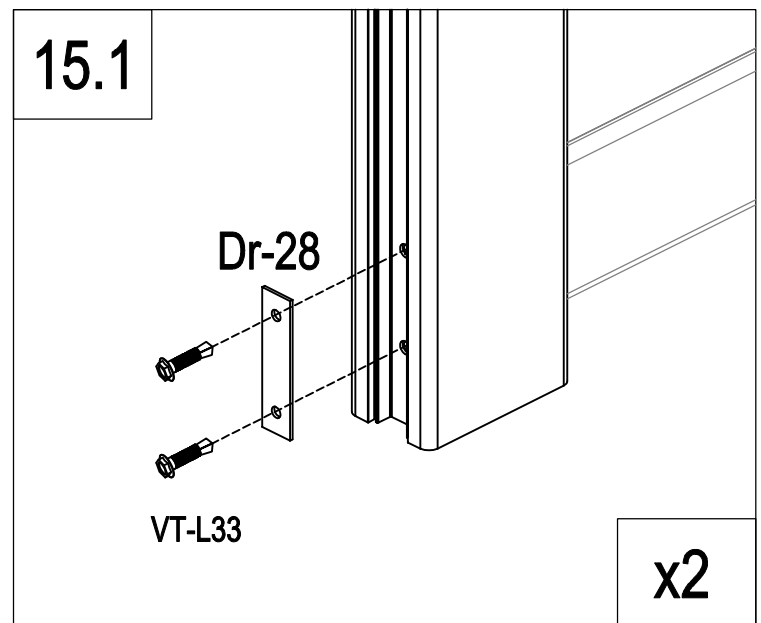
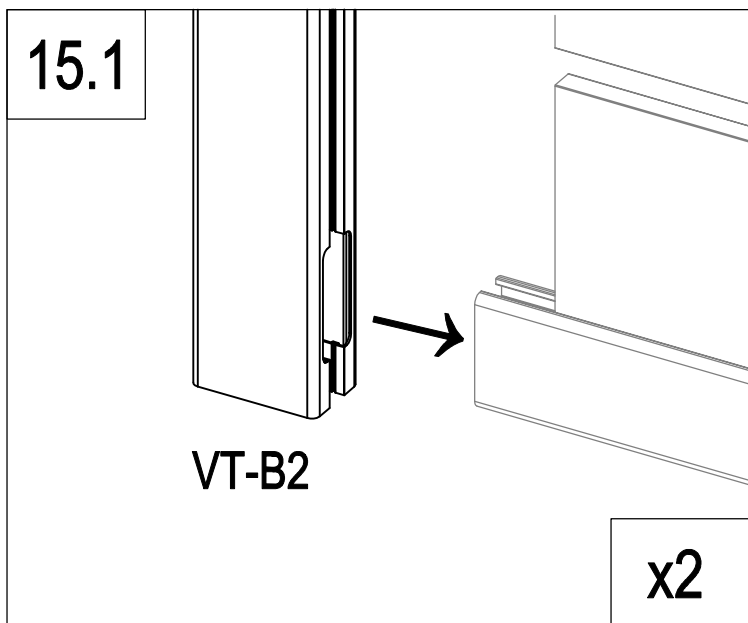
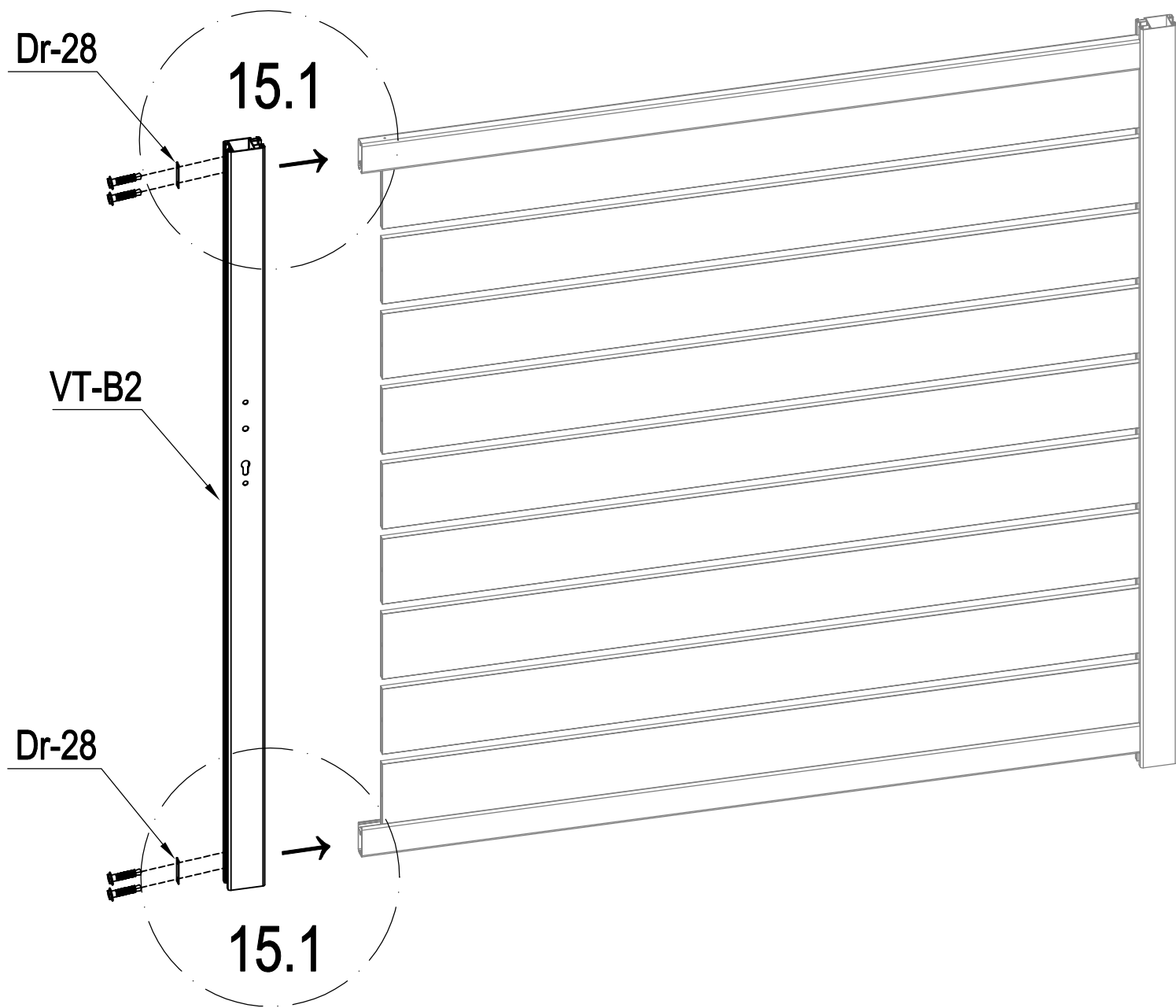

	VT-C4a (+SR-C15)	1
--	------------------	---

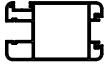

	VT-B2	1
	Dr-28	2
	VT-L33	4

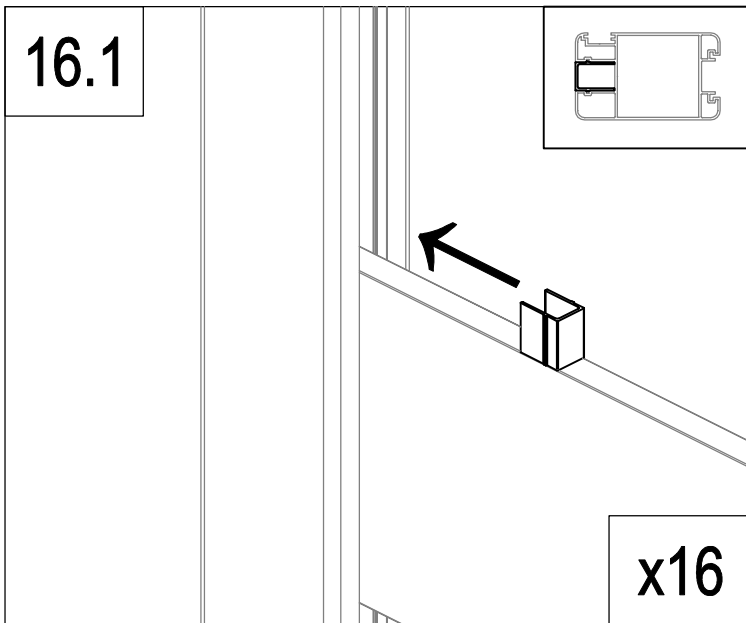
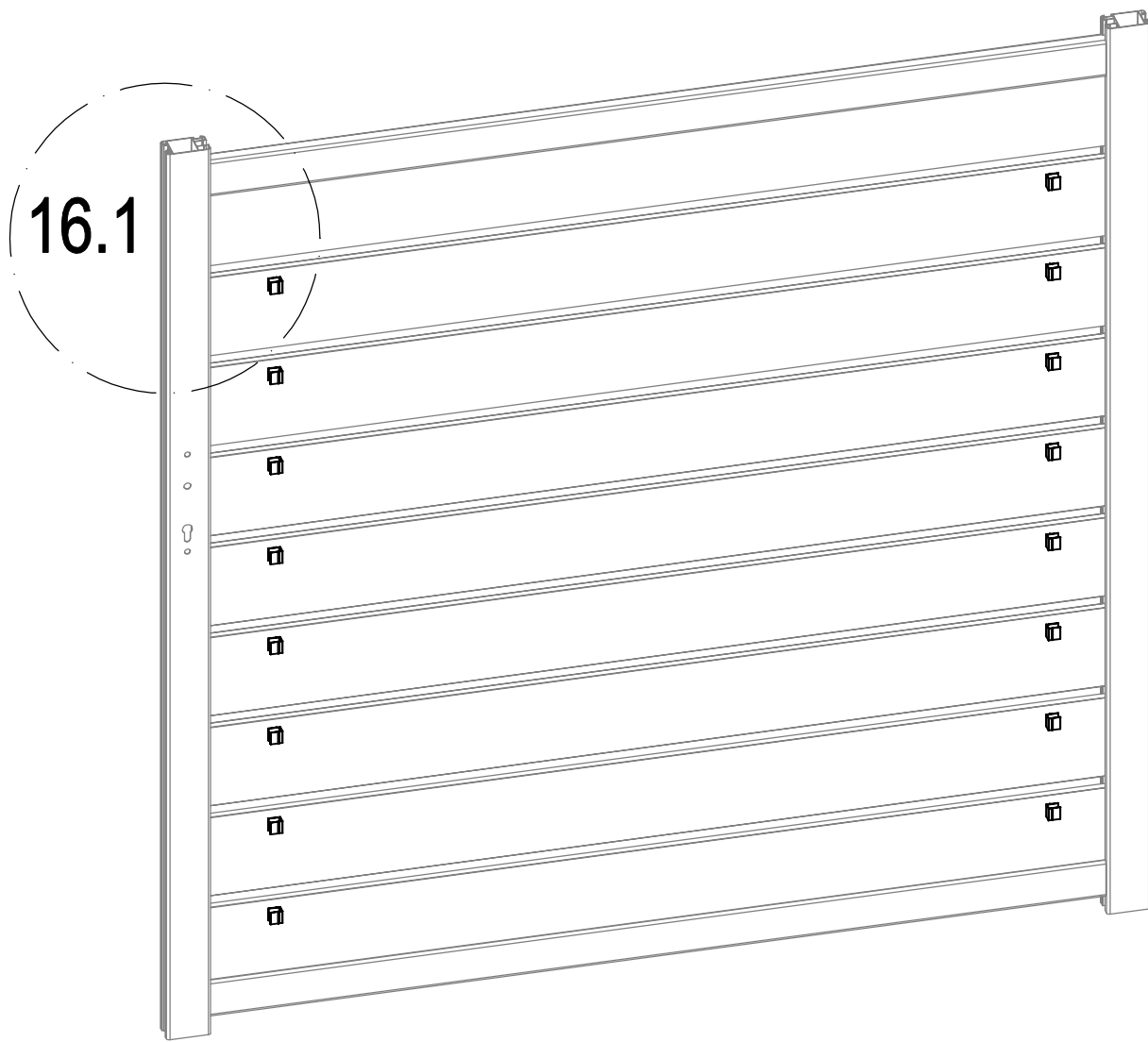

	VT-A6	16
---	-------	----

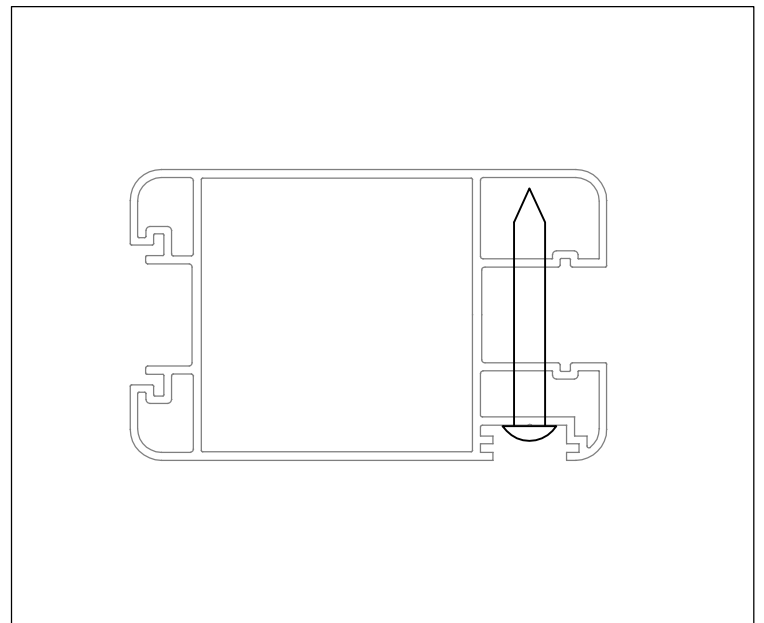
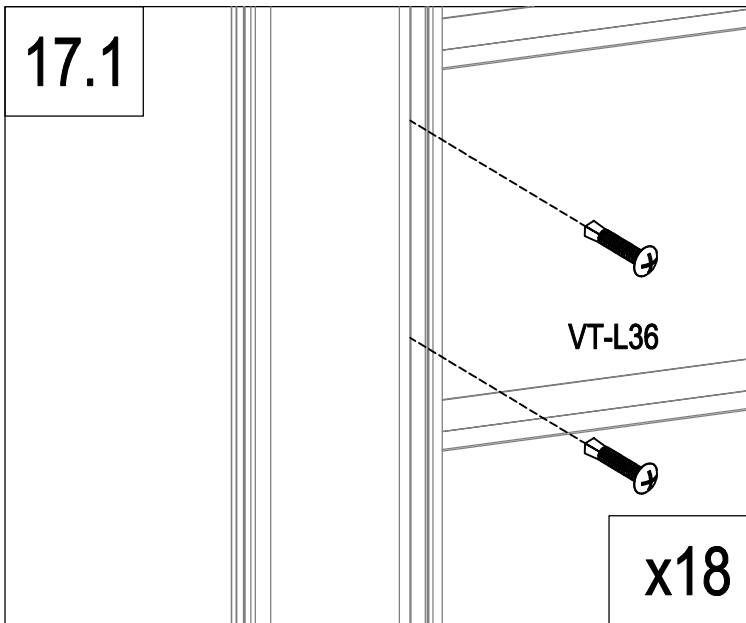
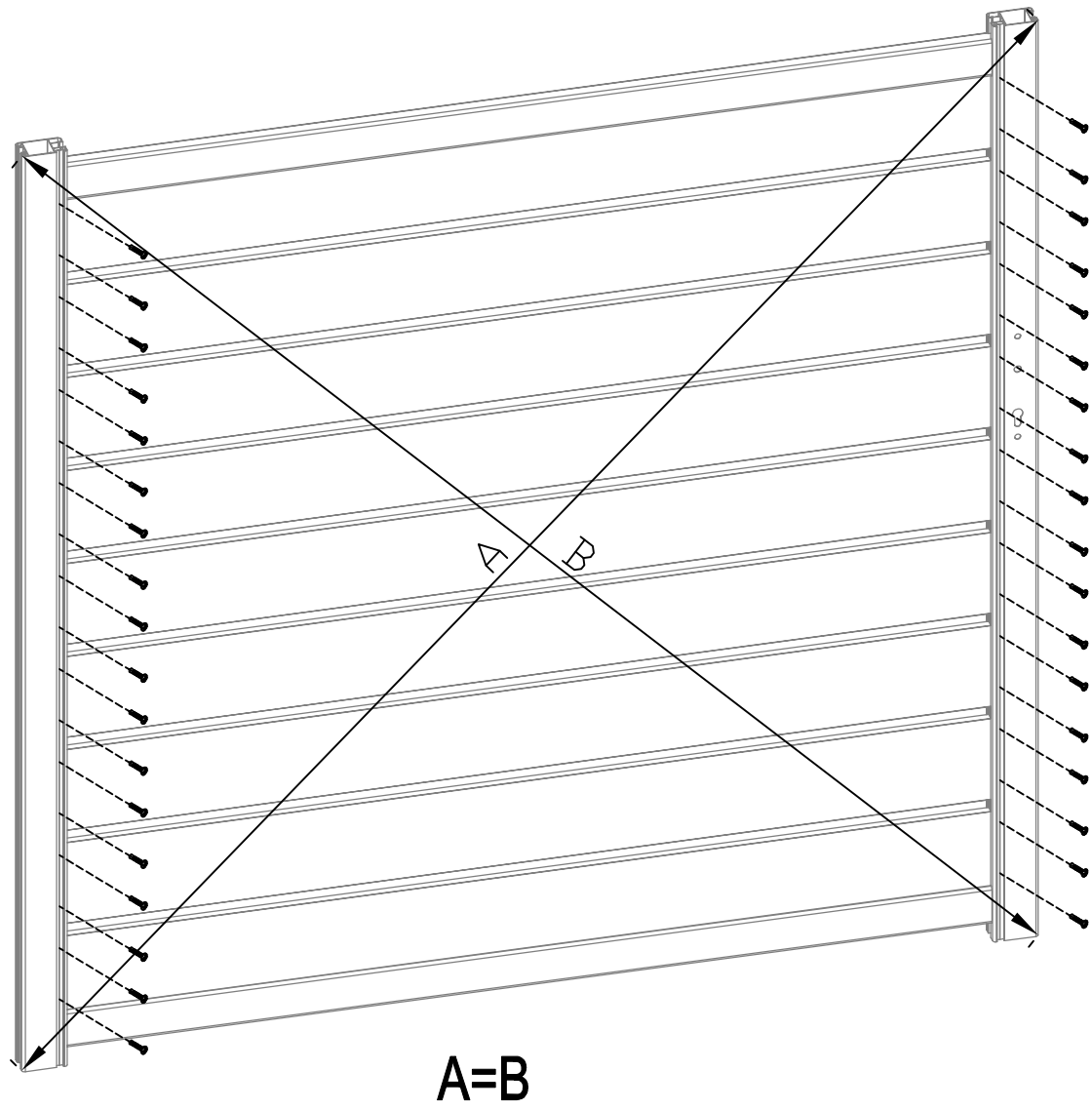
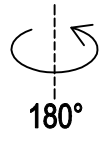

	VT-L36	36
--	--------	----

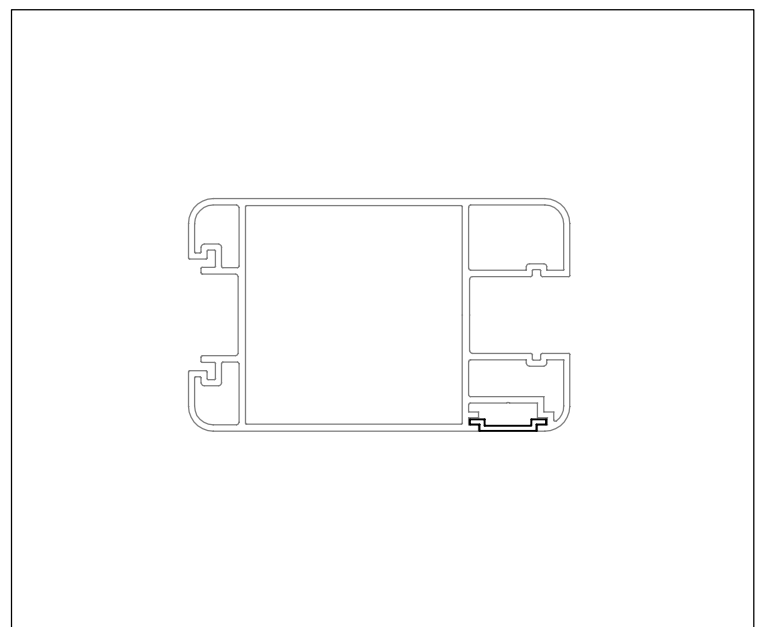
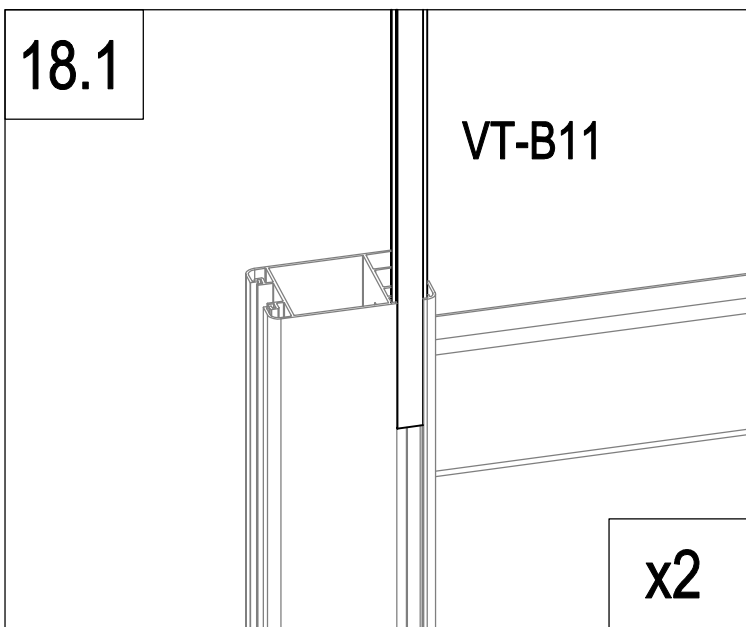
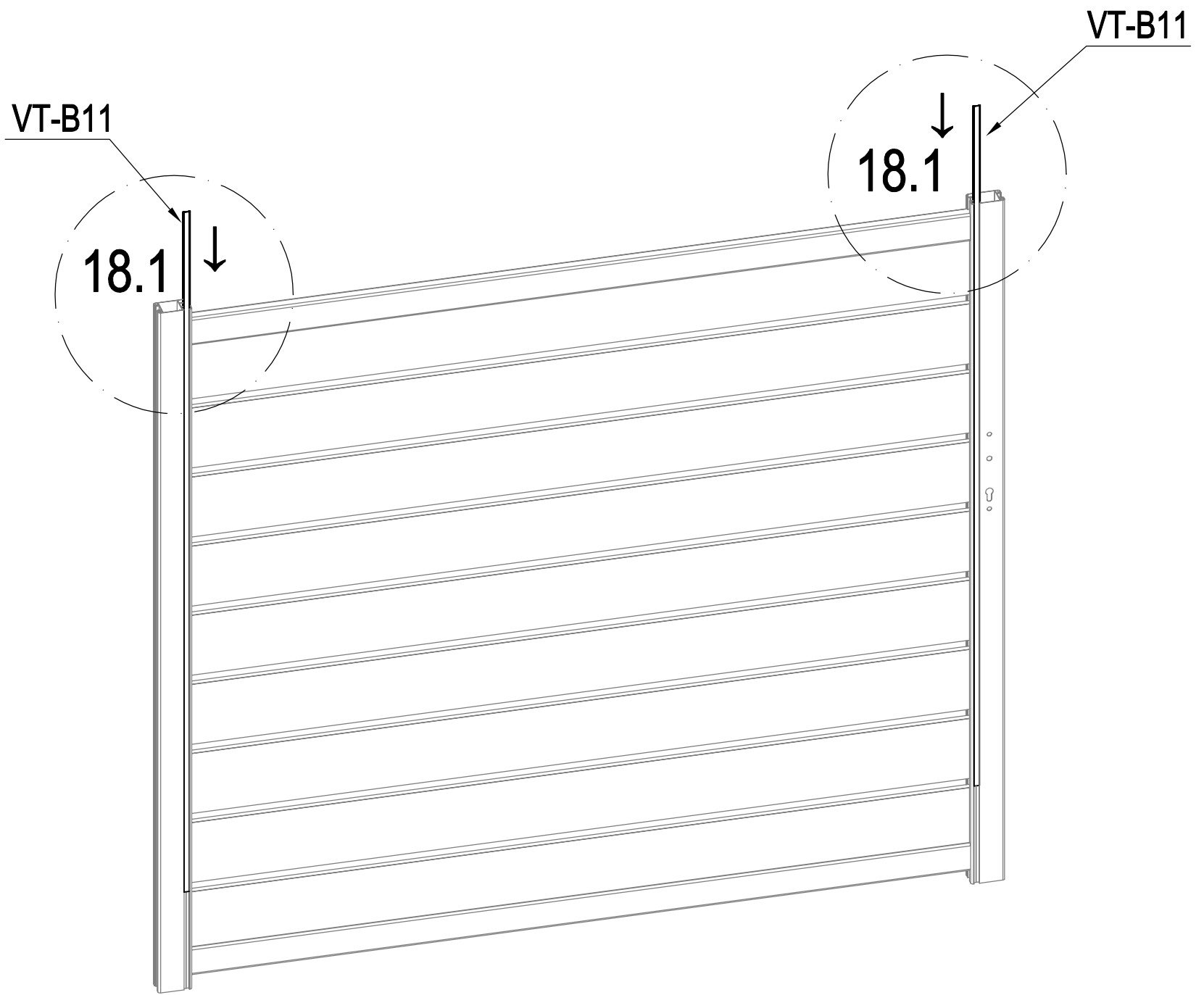

	VT-B11	2
---	--------	---

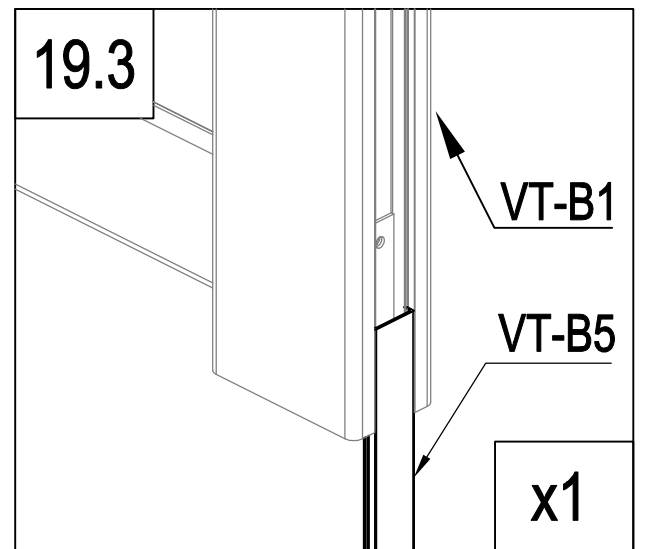
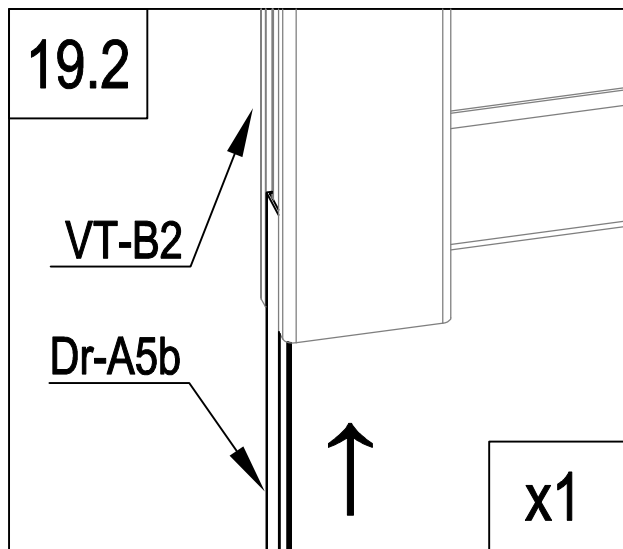
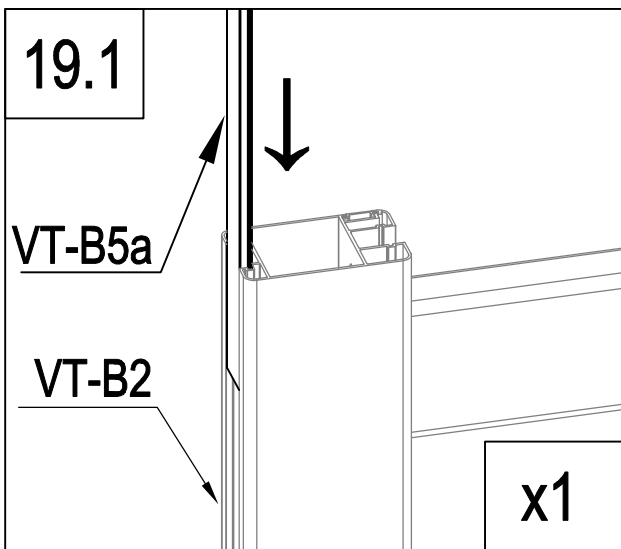
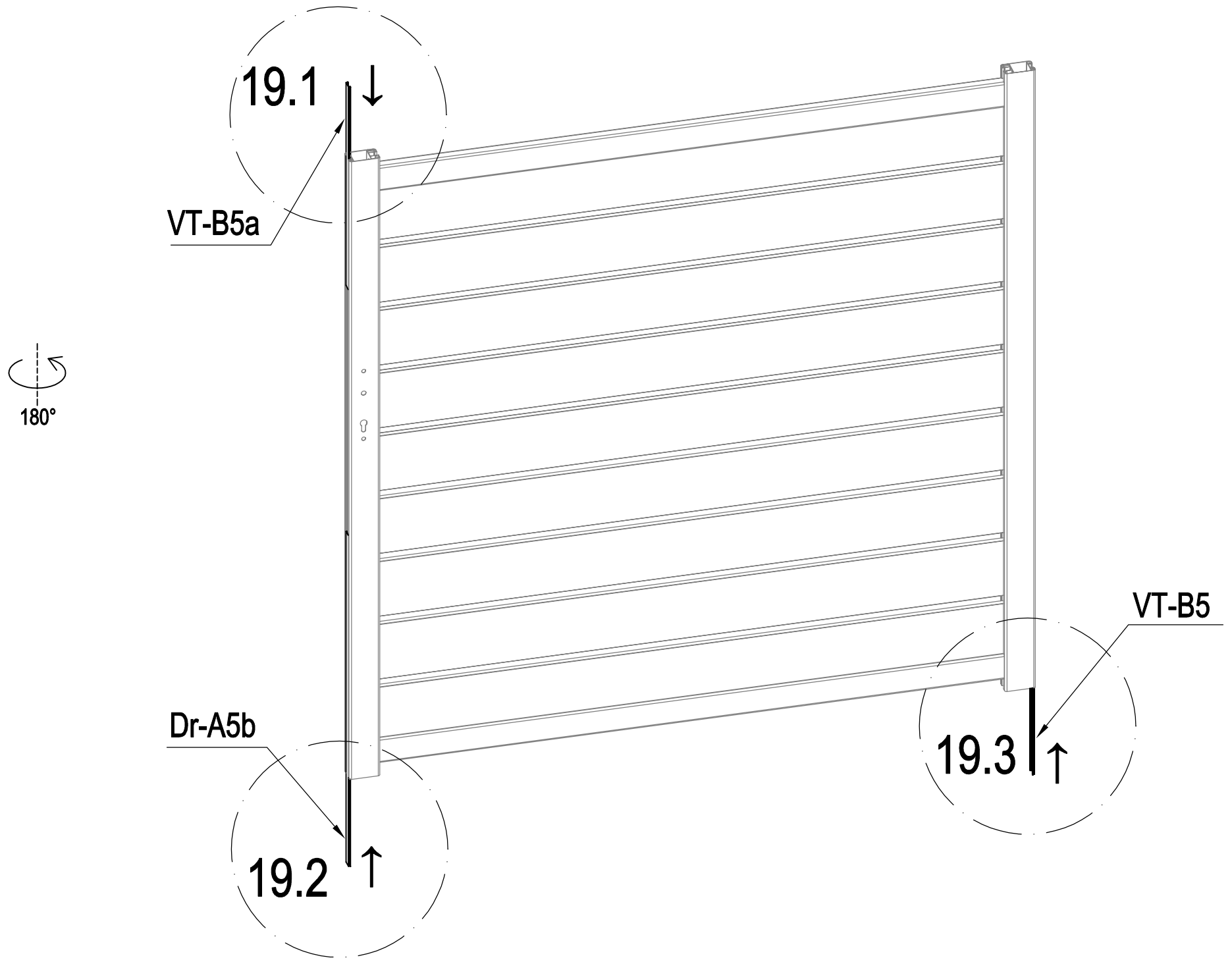

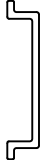
	VT-B5	1
	VT-B5a	1
	Dr-A5b	1

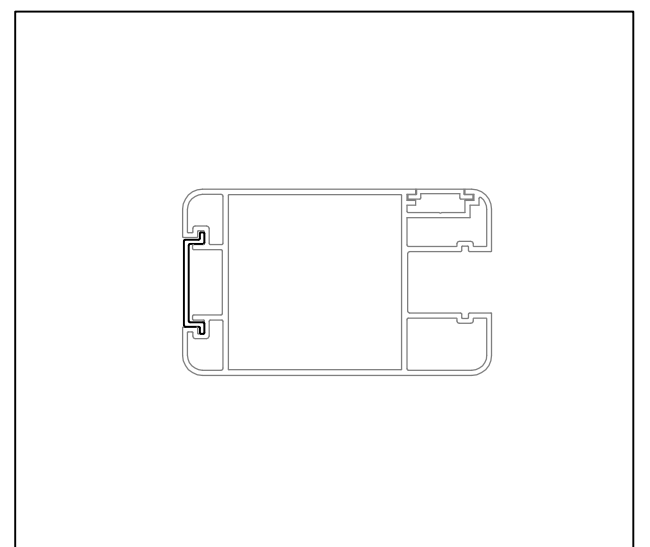

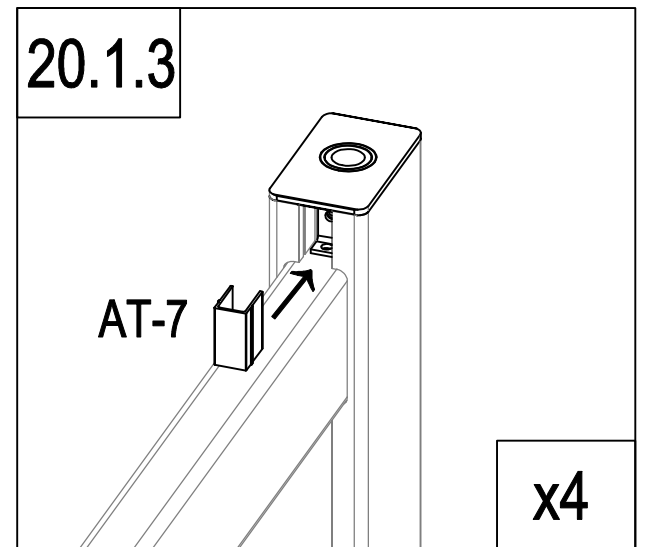
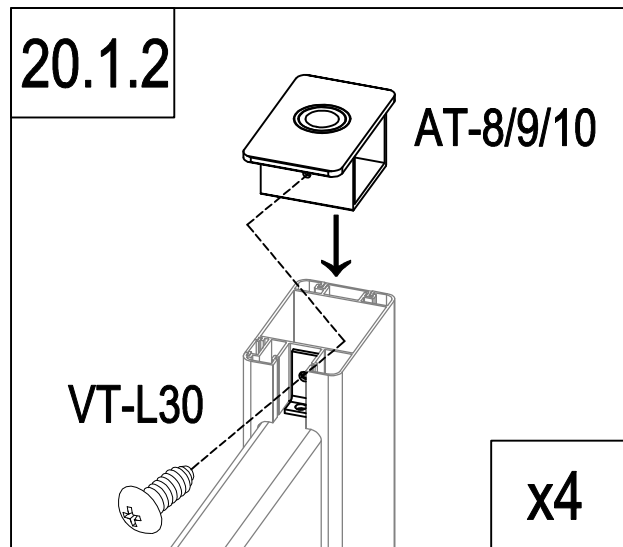
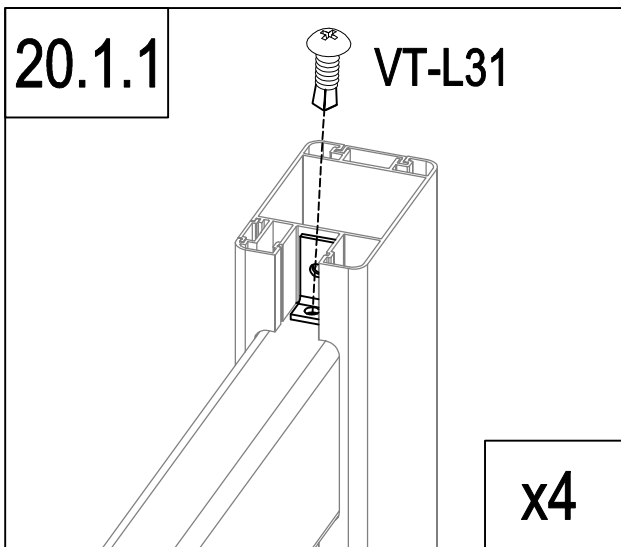
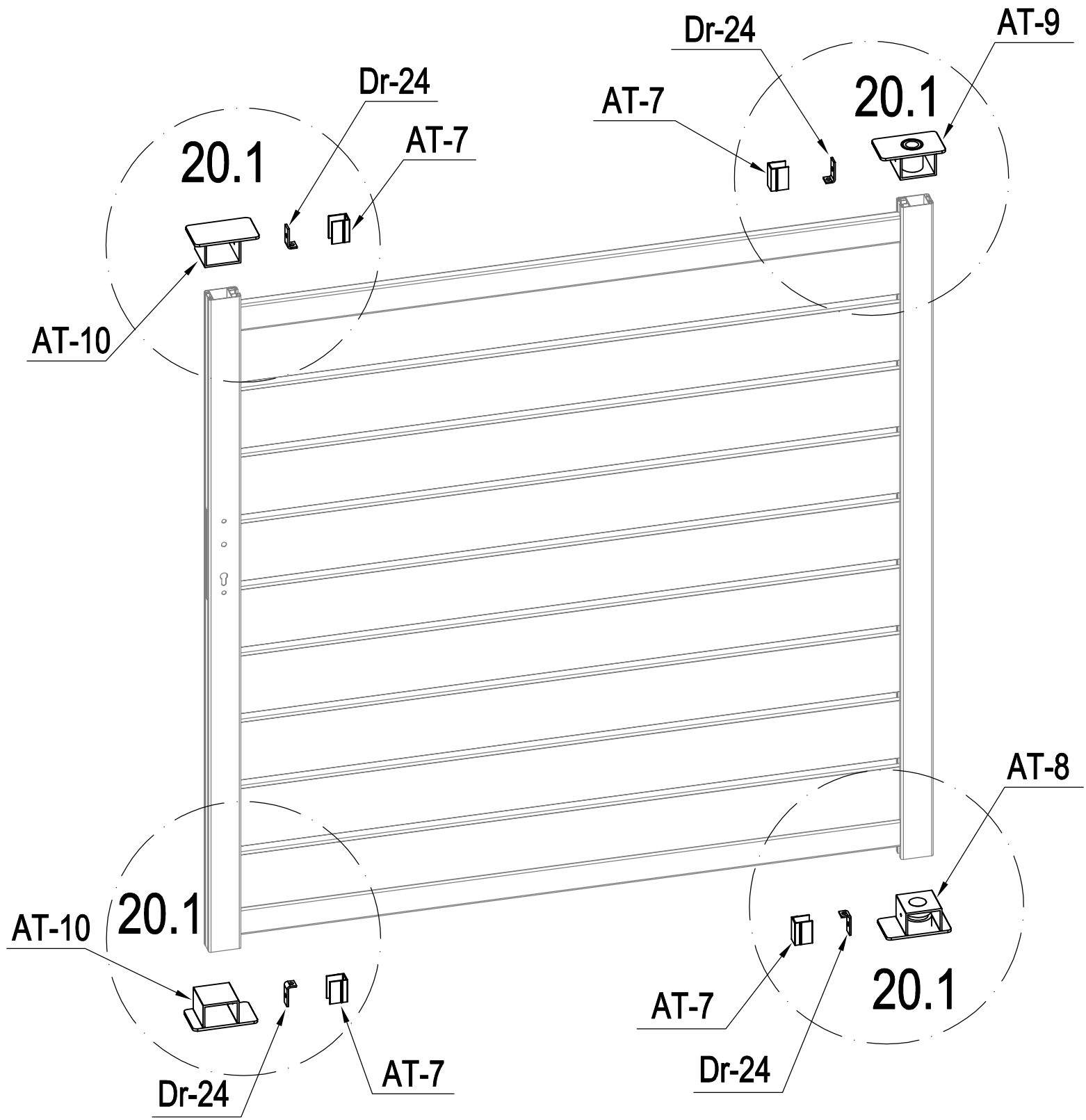

	<b>AT-8</b>	<b>1</b>
	<b>AT-9</b>	<b>1</b>
	<b>AT-10</b>	<b>2</b>
	<b>Dr-24</b>	<b>4</b>

	<b>AT-7</b>	<b>4</b>
	<b>VT-L30</b>	<b>4</b>
	<b>VT-L31</b>	<b>4</b>

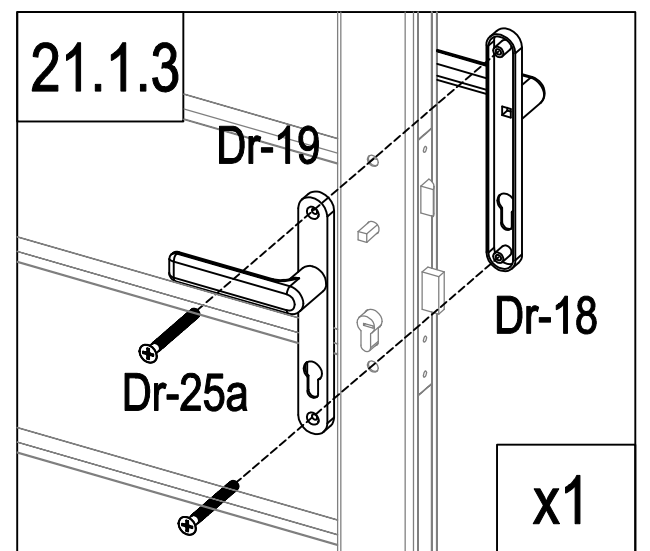
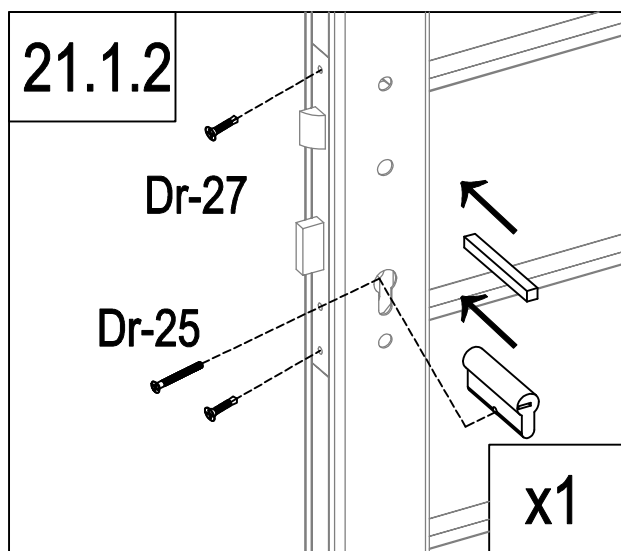
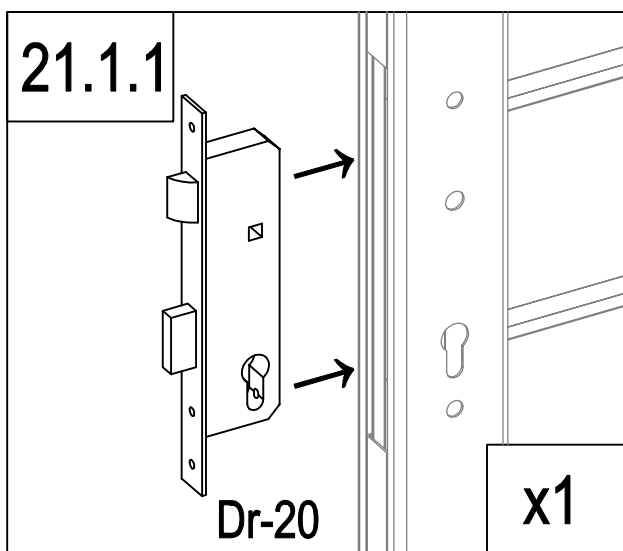
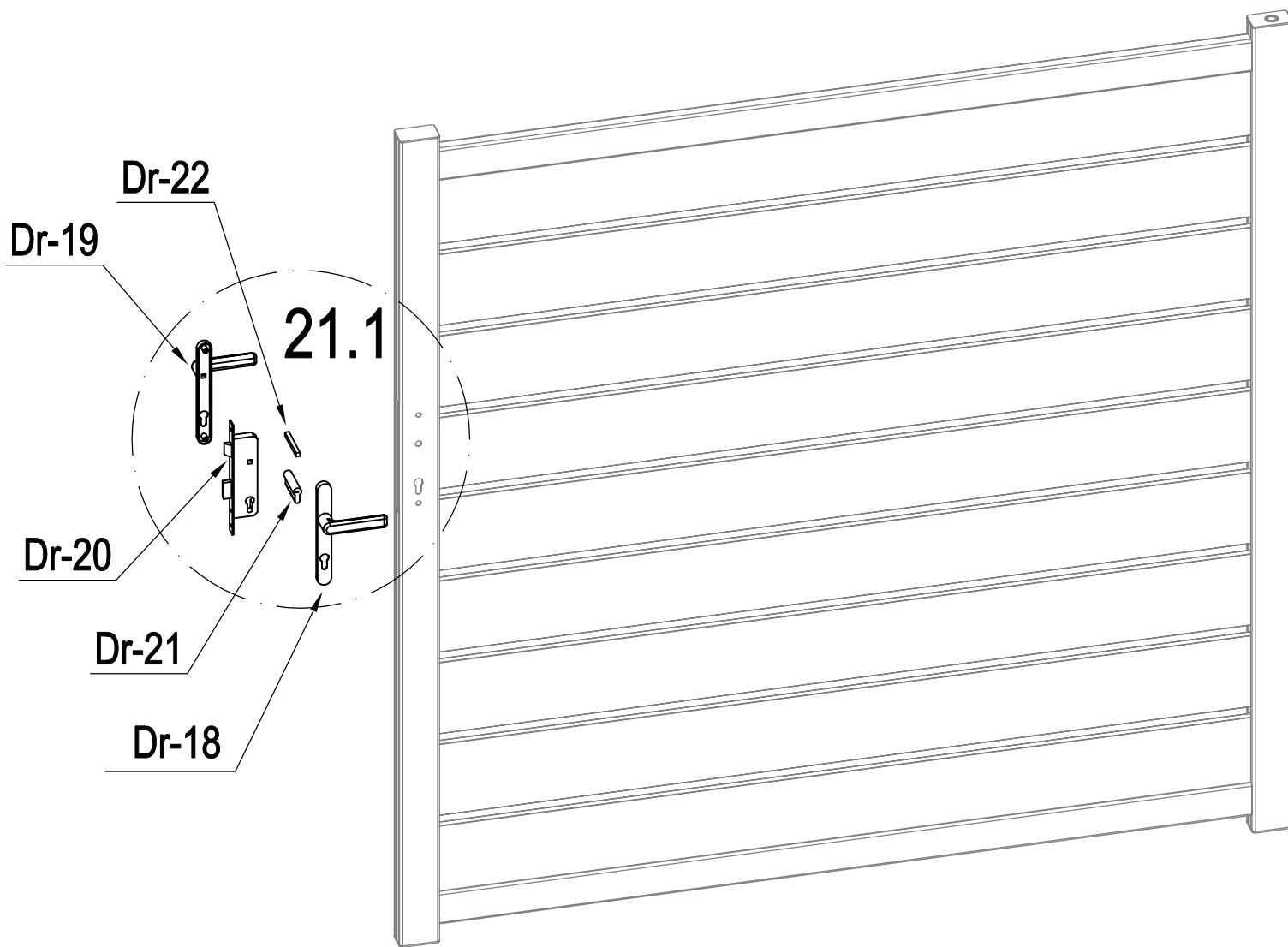

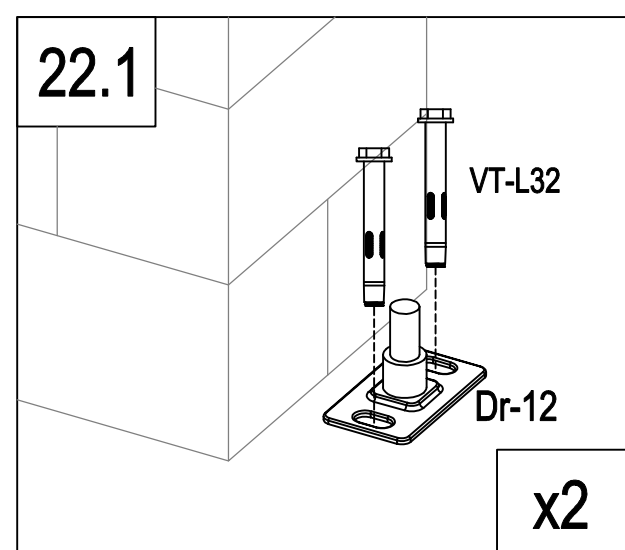
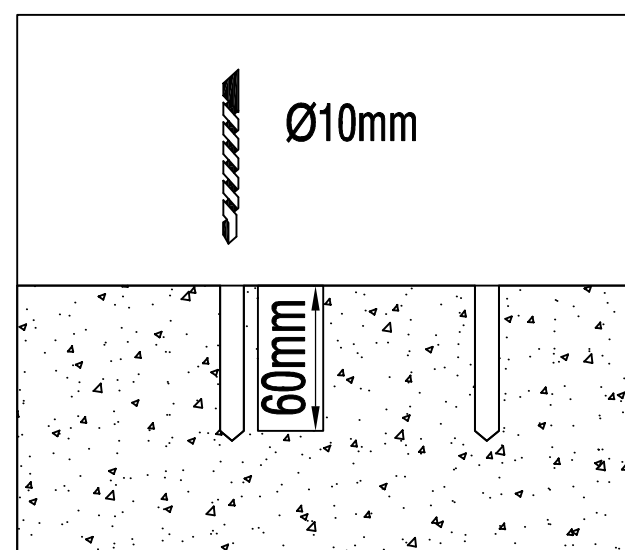
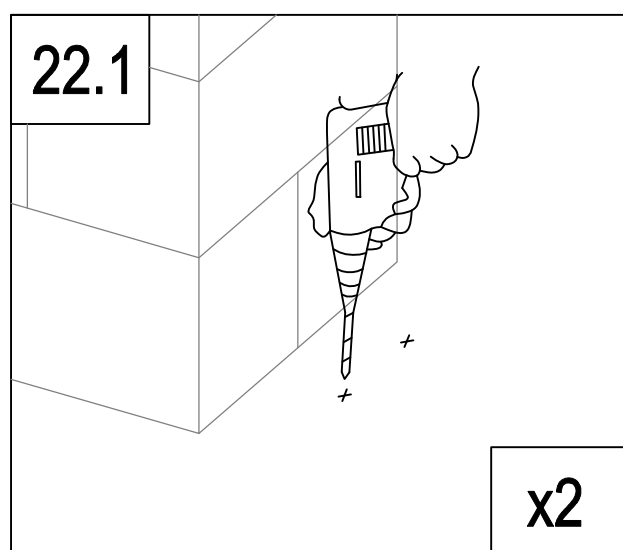
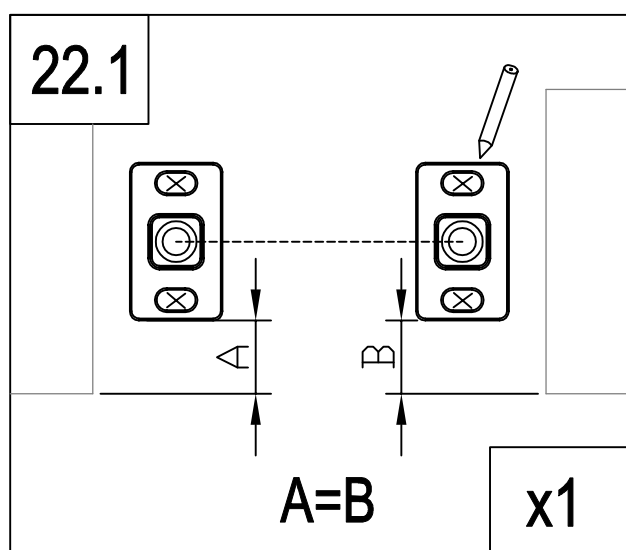
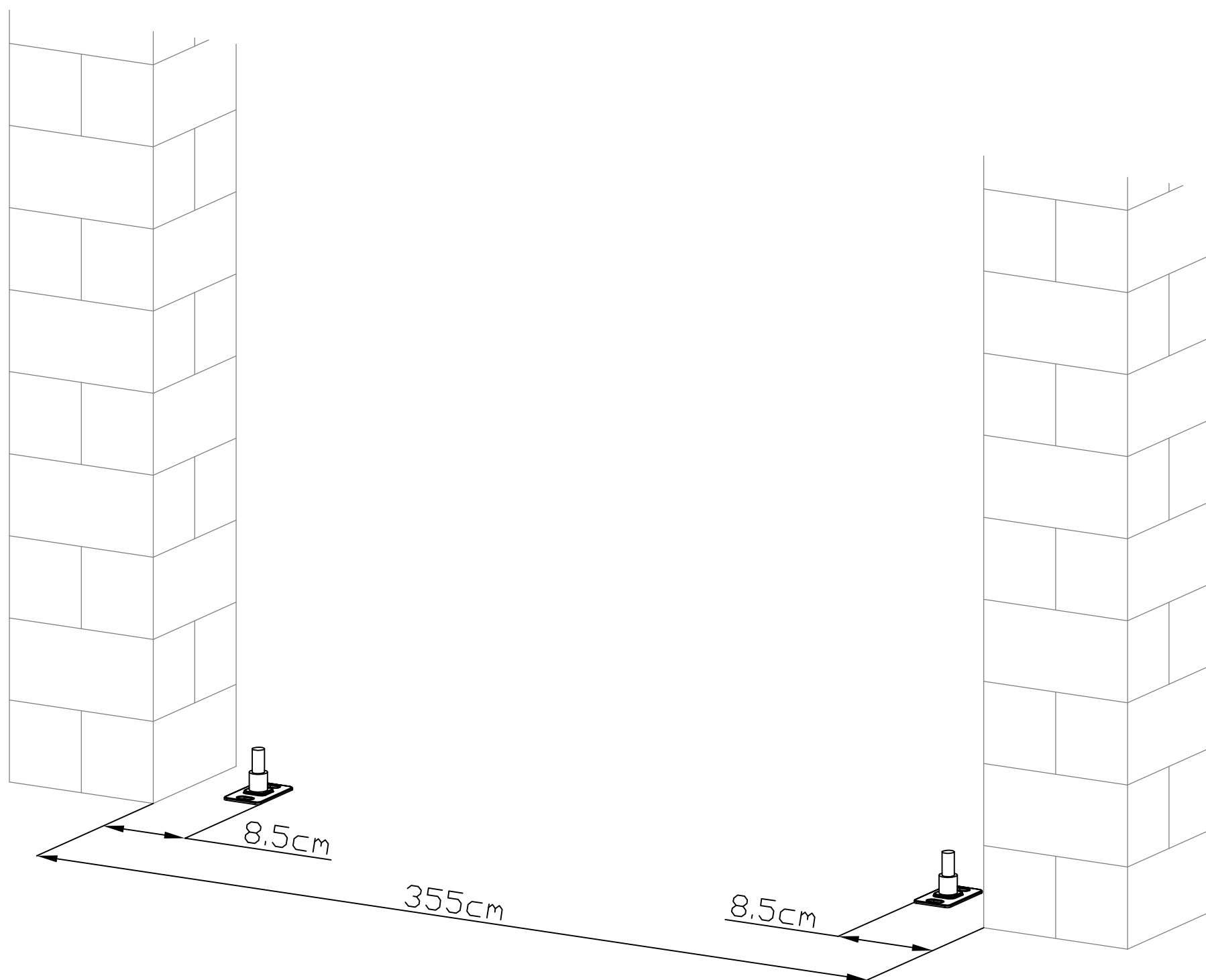

	Dr-20	1
	Dr-21	1
	Dr-22	1
	Dr-25	1

	Dr-18	1
	Dr-19	1
	Dr-25a	2
	Dr-27	2



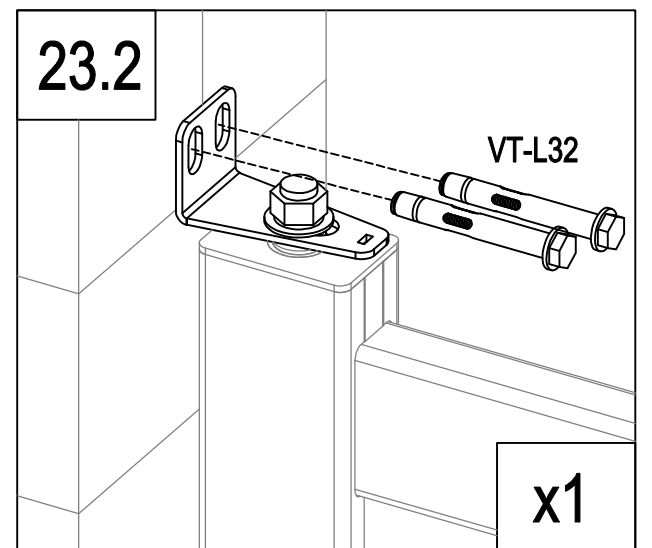
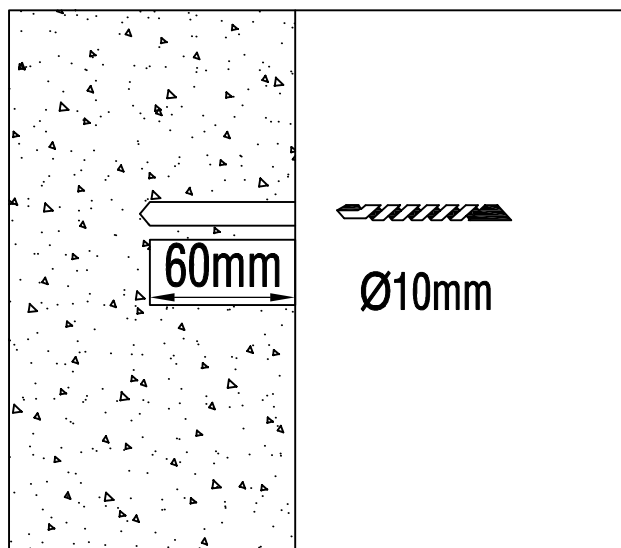
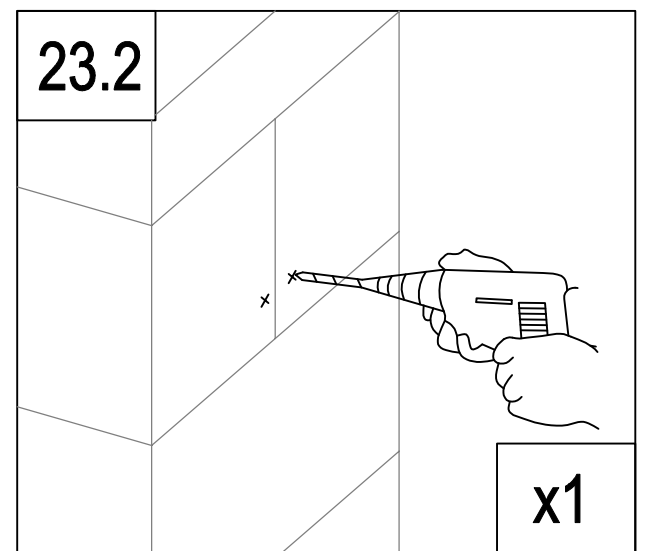
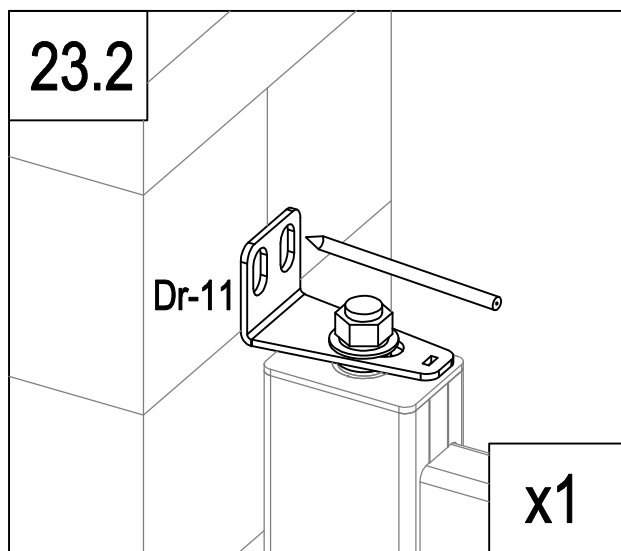
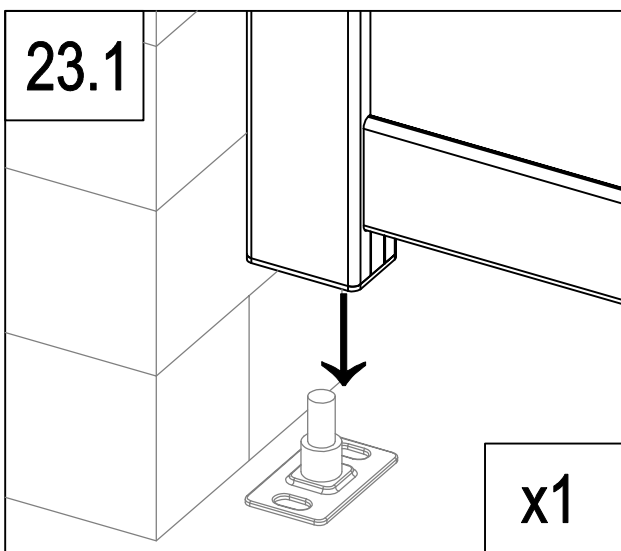
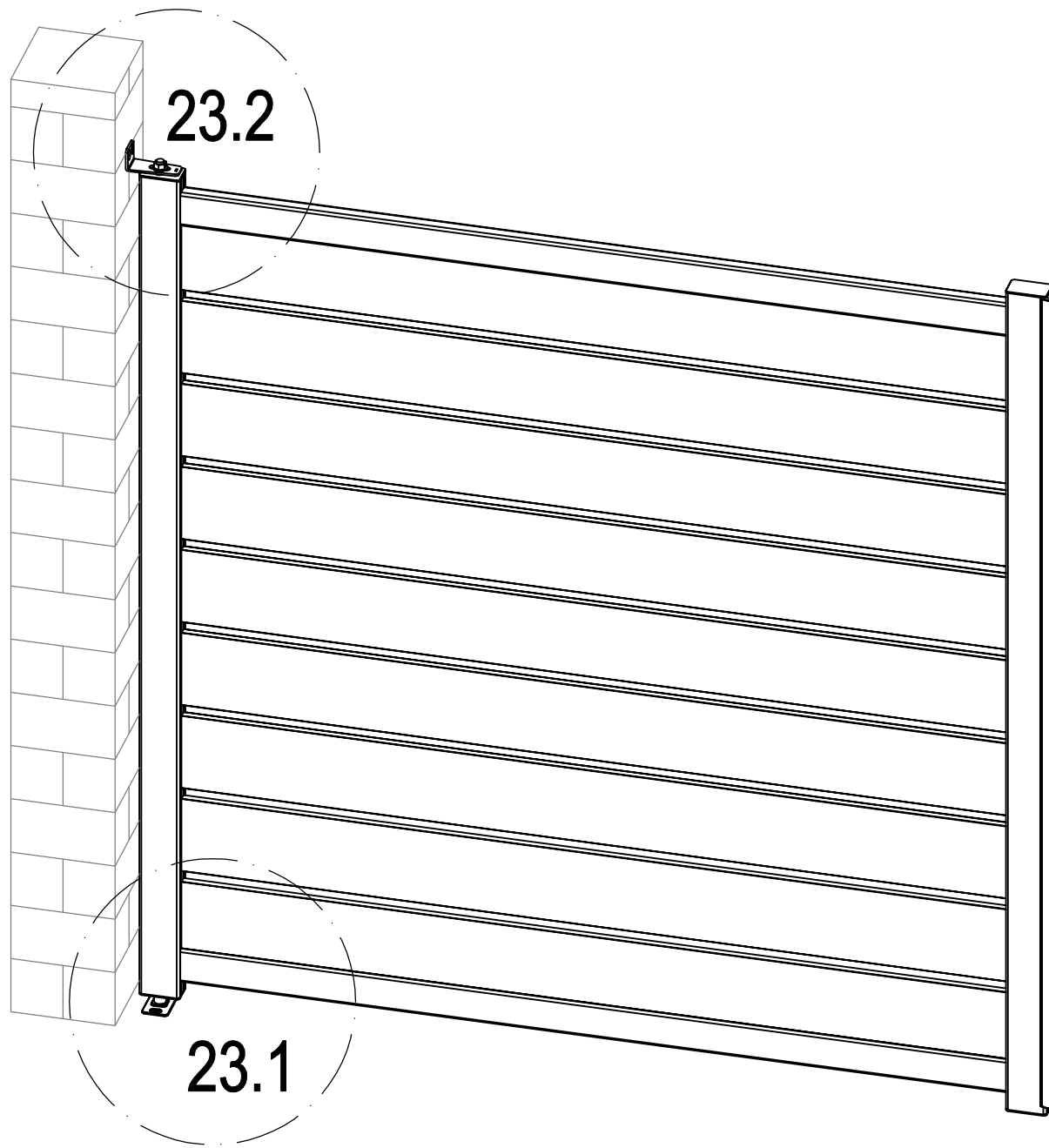

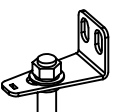
	Dr-12	2
	VT-L32	4



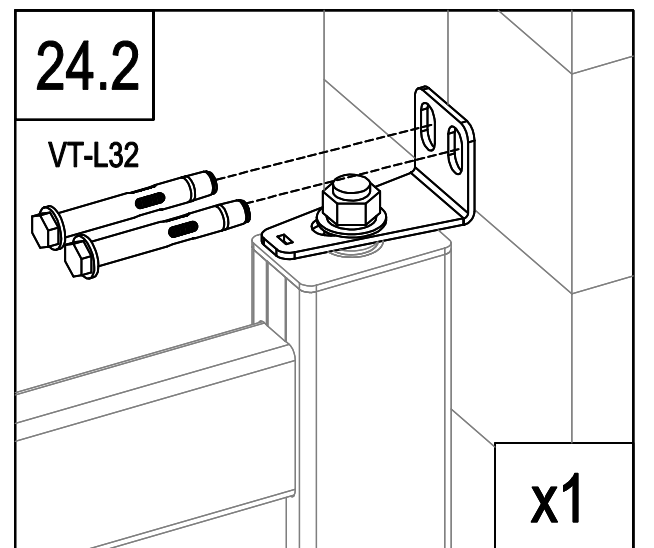
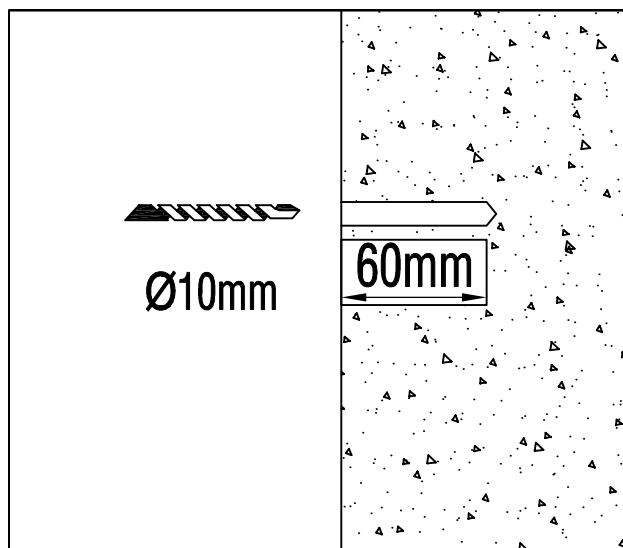
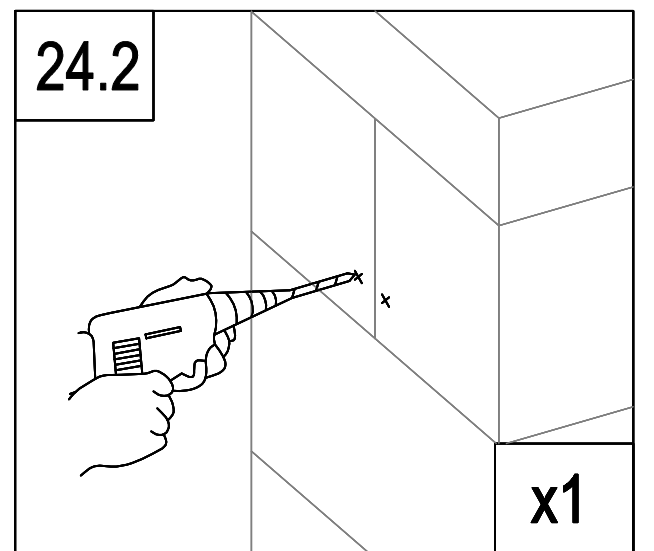
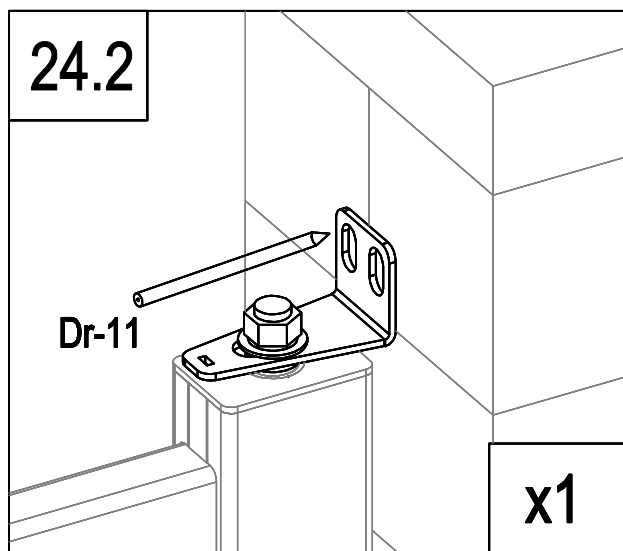
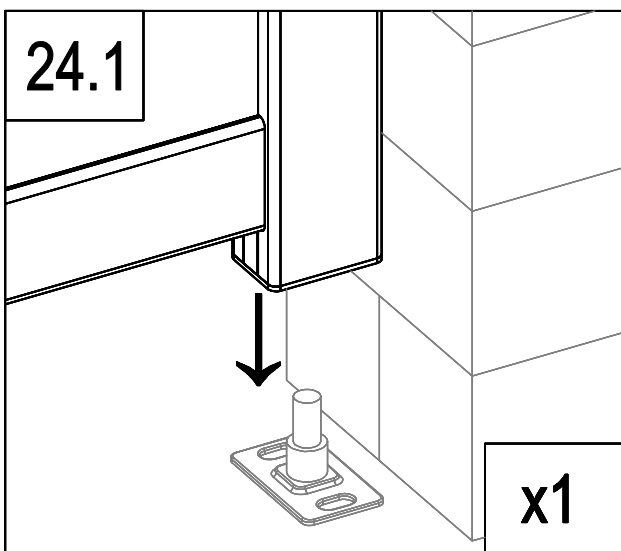
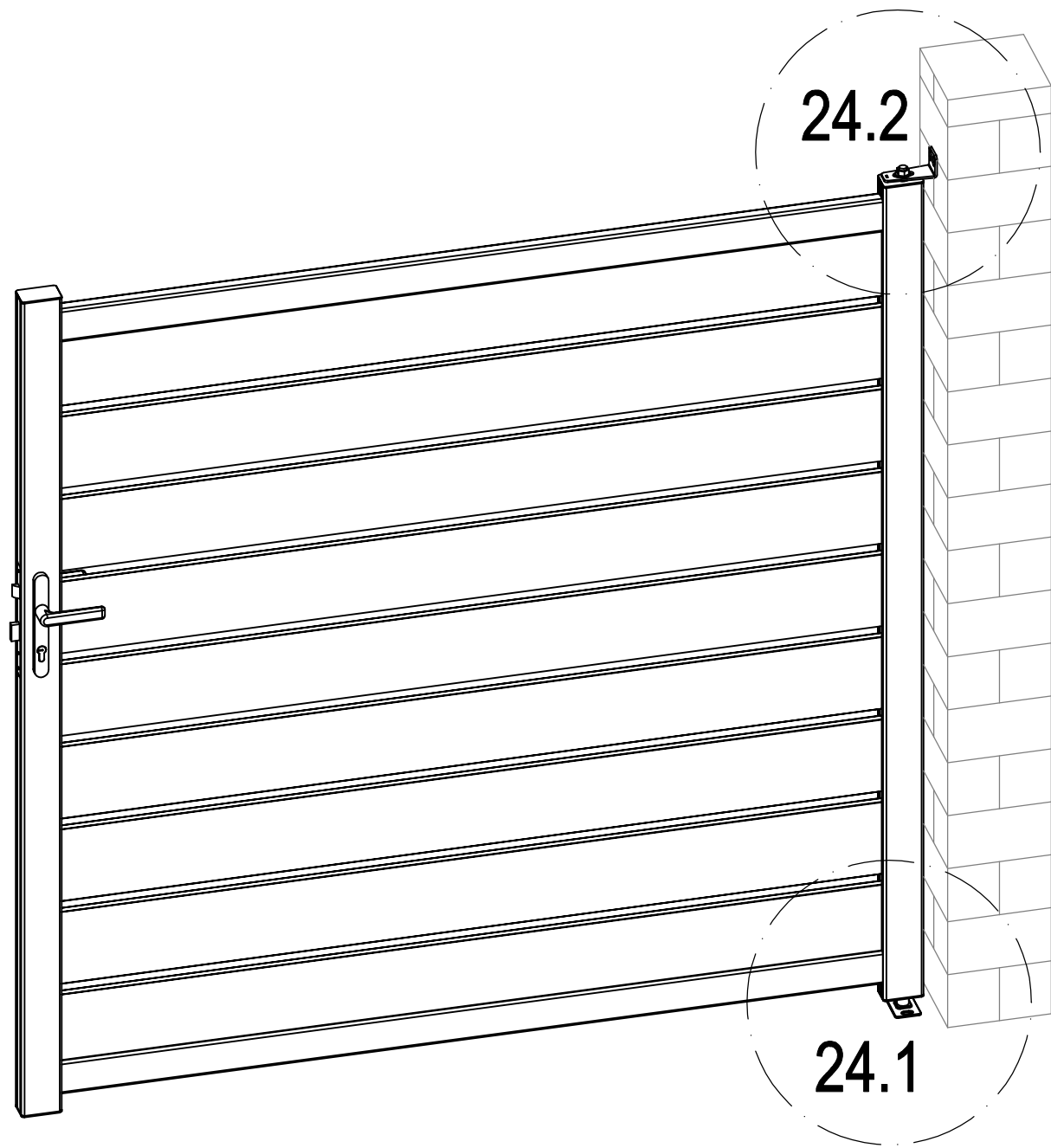

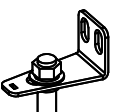
	Dr-11	1
	VT-L32	2

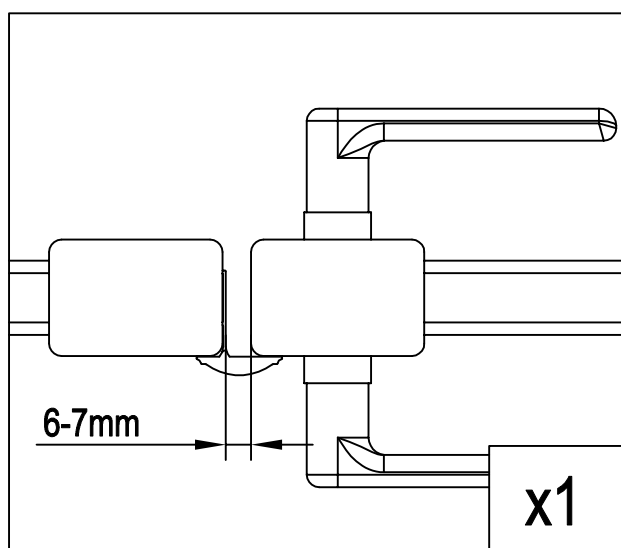
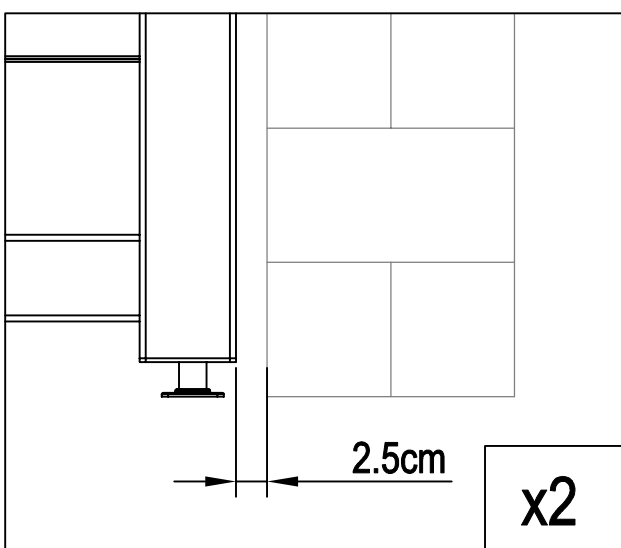
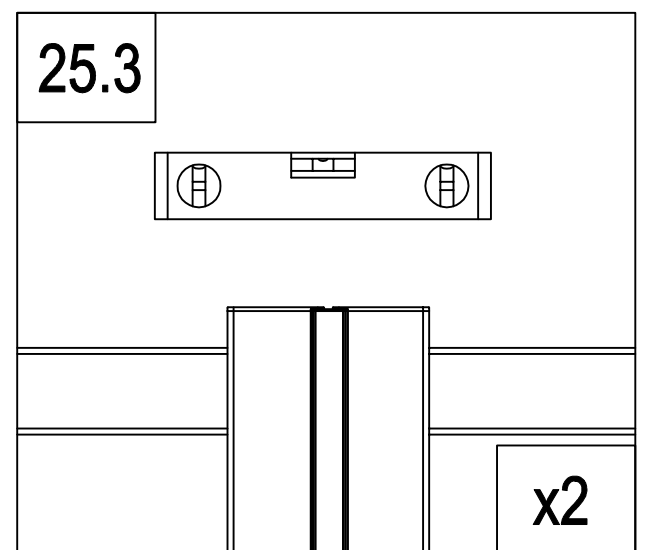
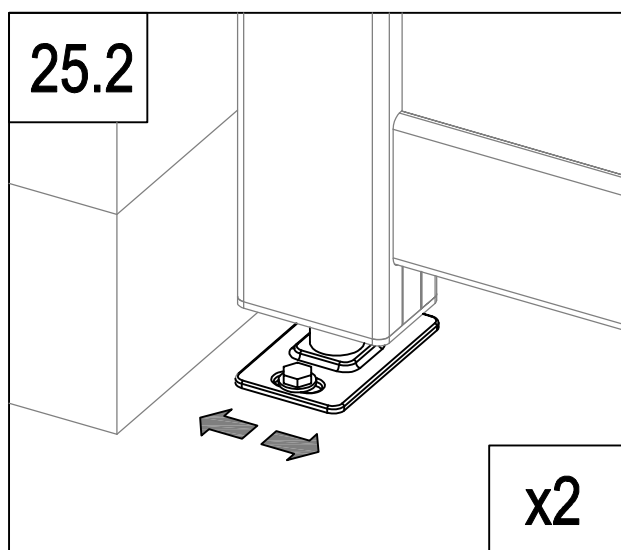
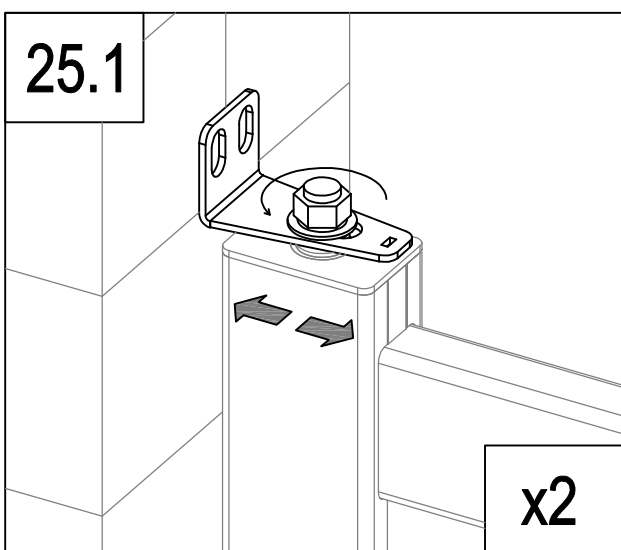
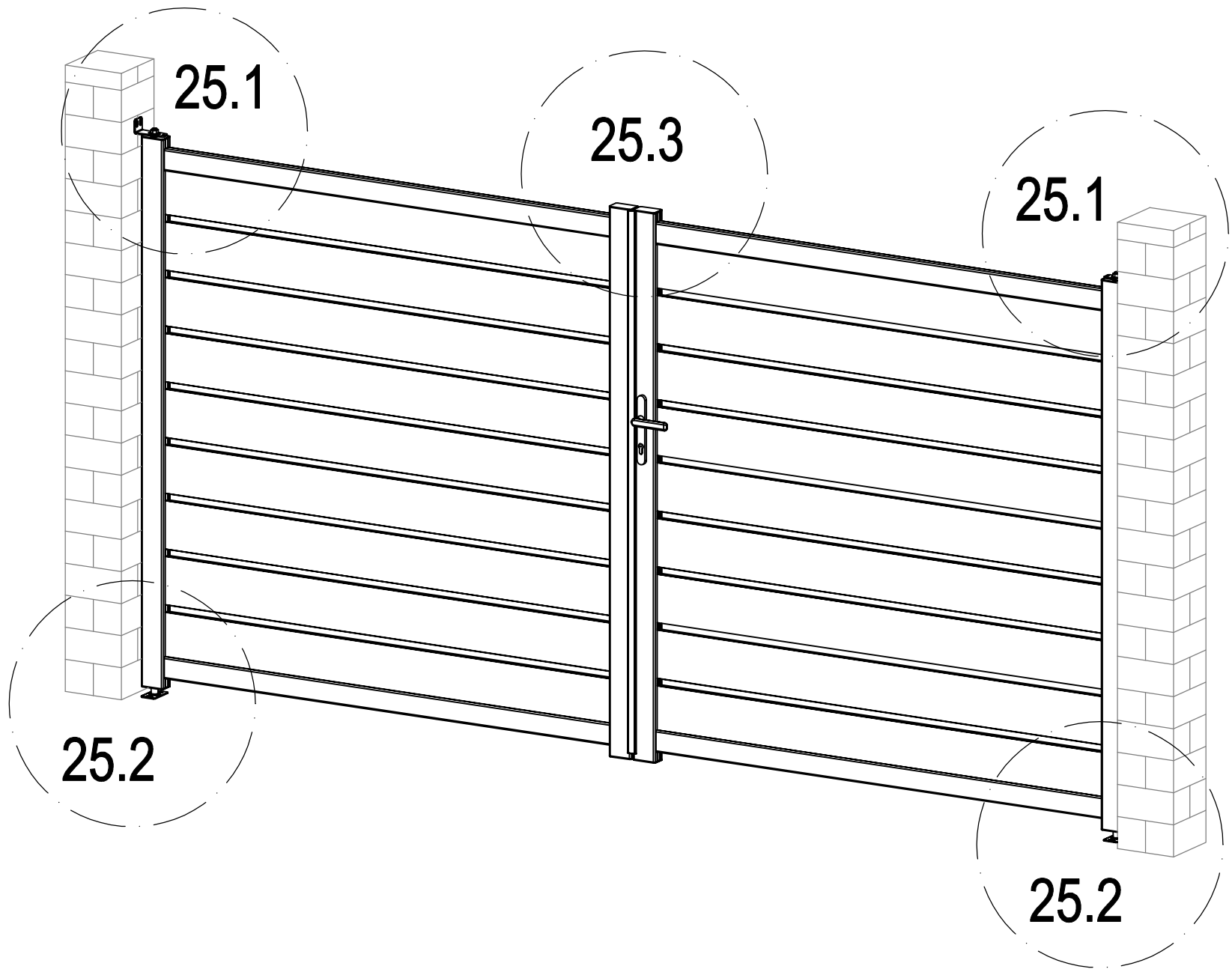

	Dr-11	1
	VT-L32	2

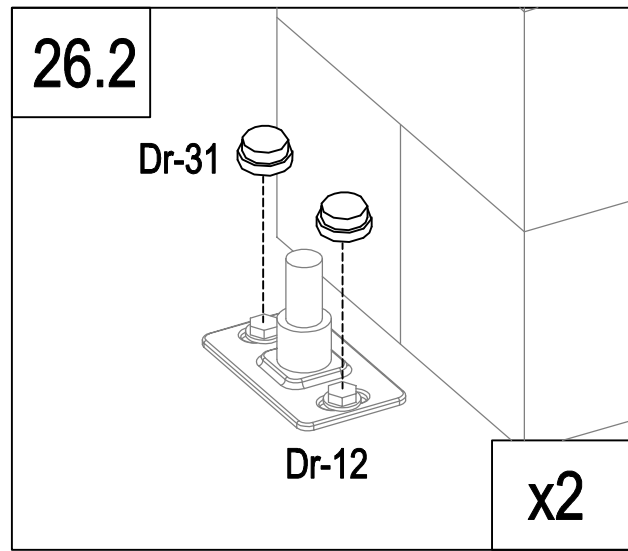
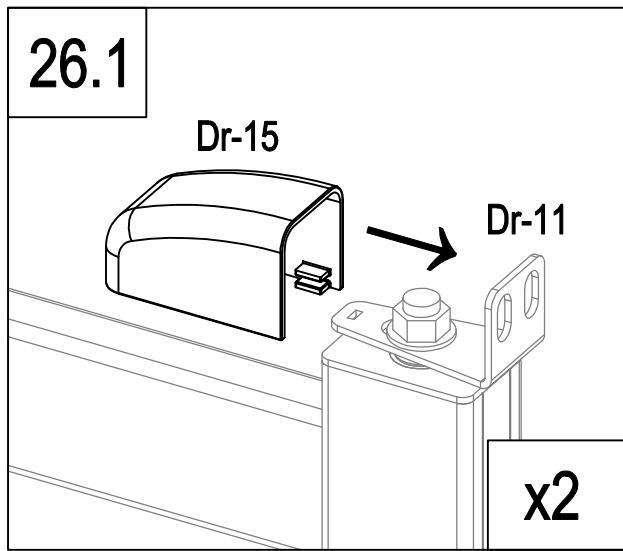
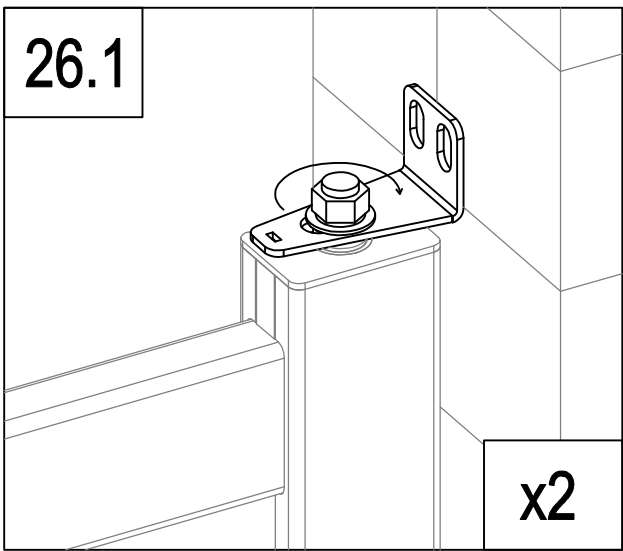
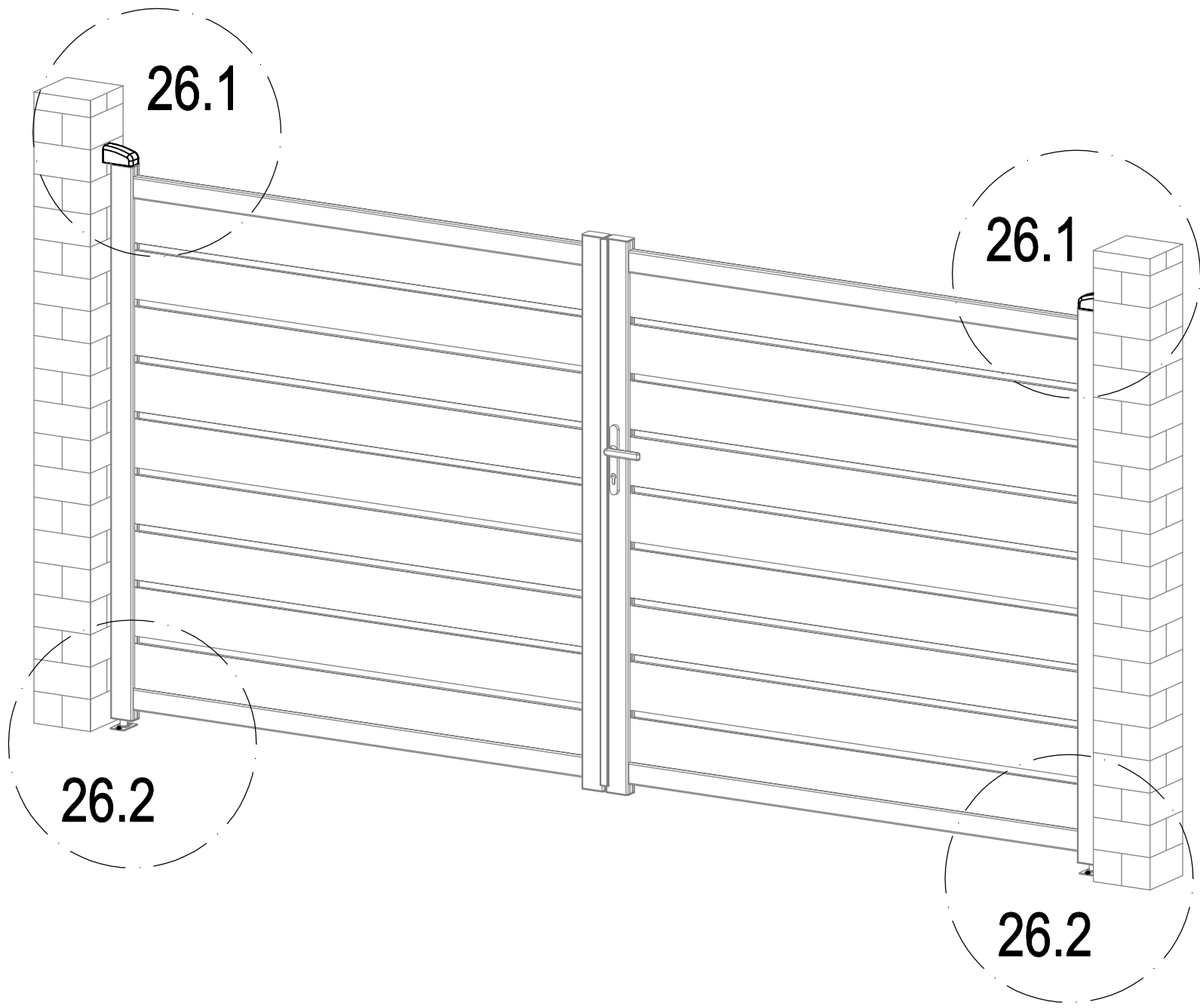

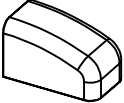

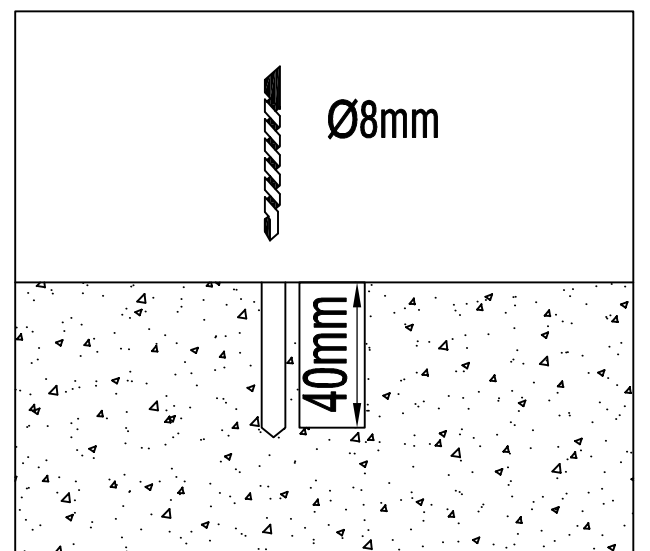
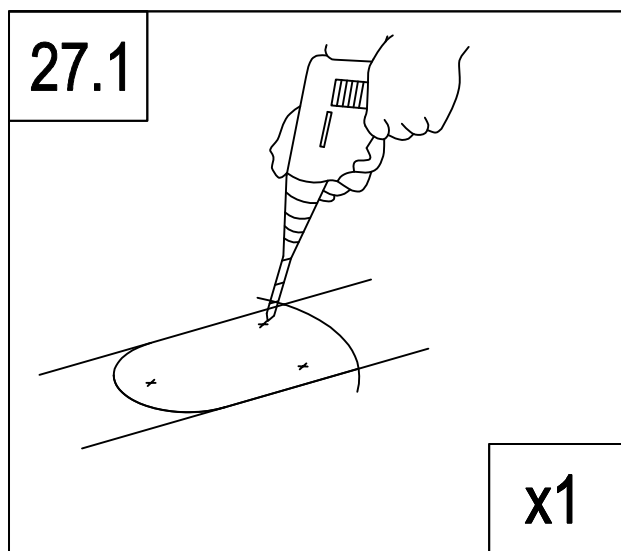
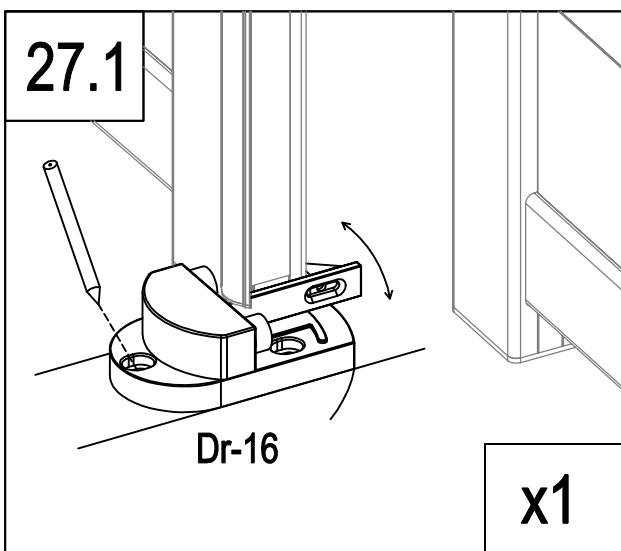
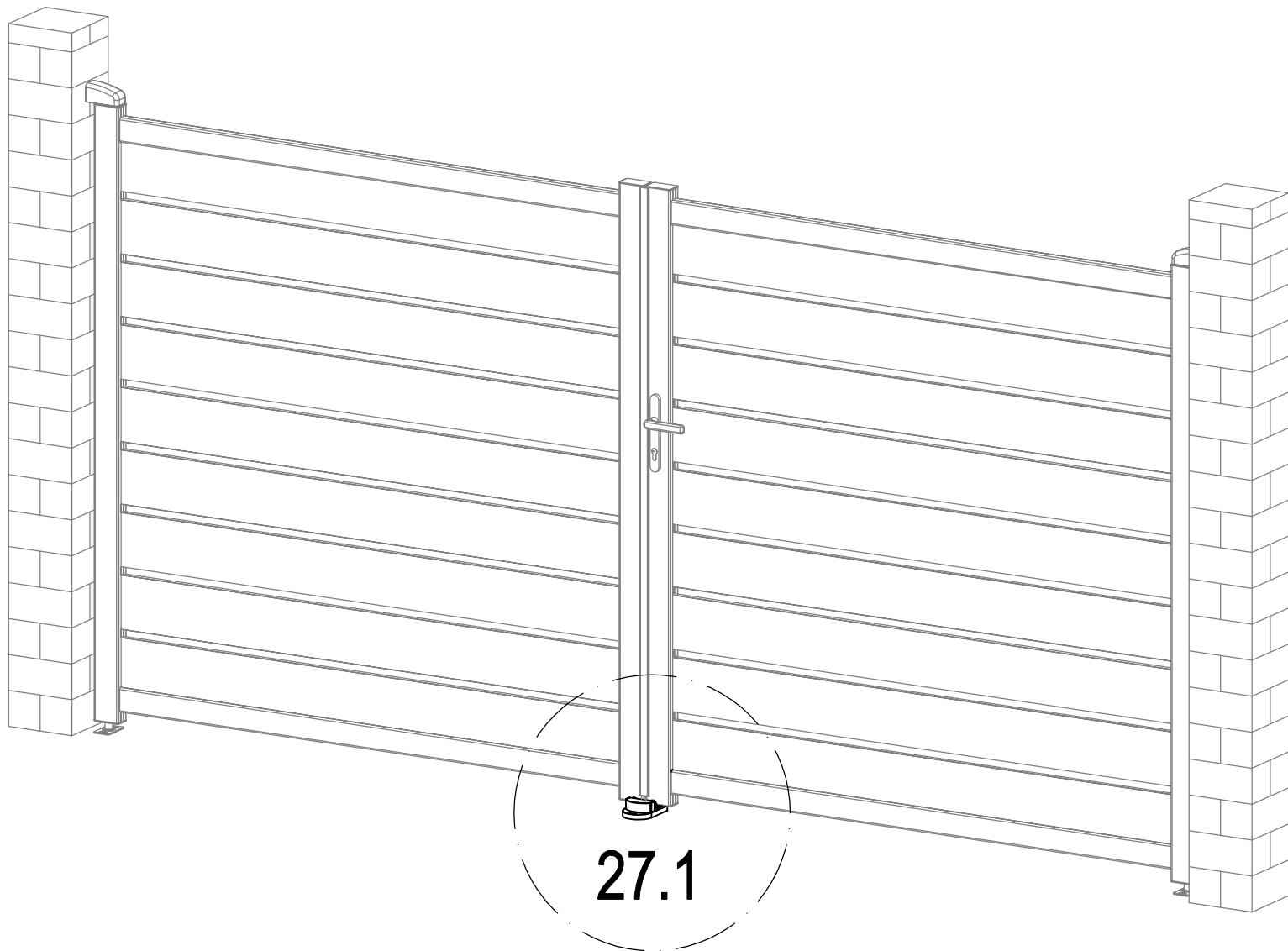

	Dr-15	2
	Dr-31	4

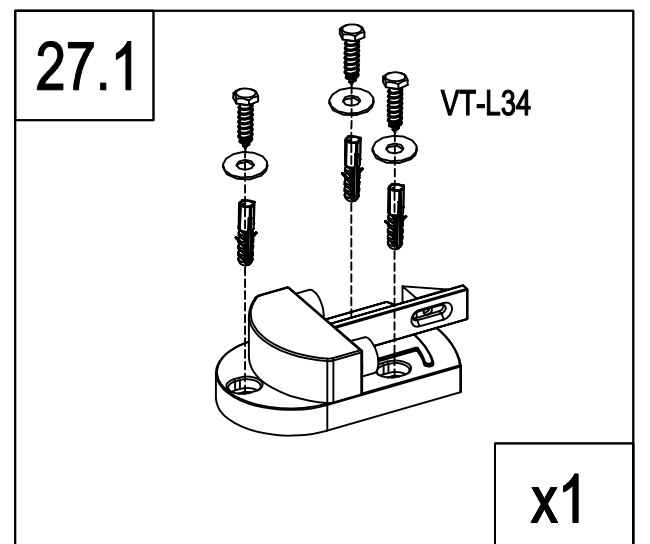

	Dr-16	1
	VT-L34	3
	VT-L35	3

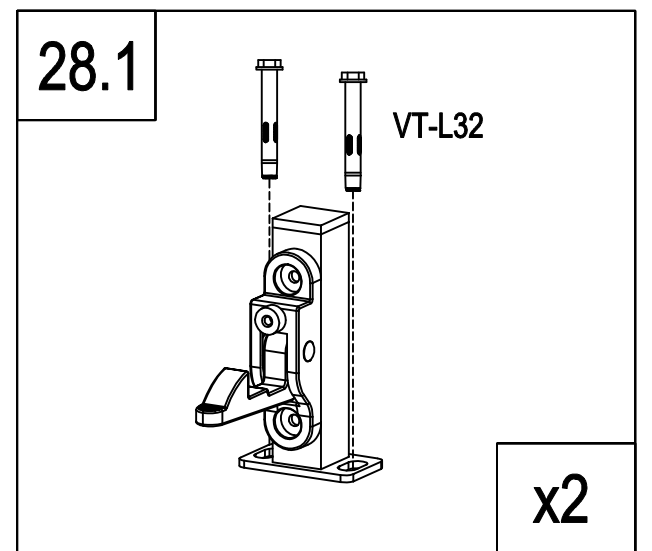
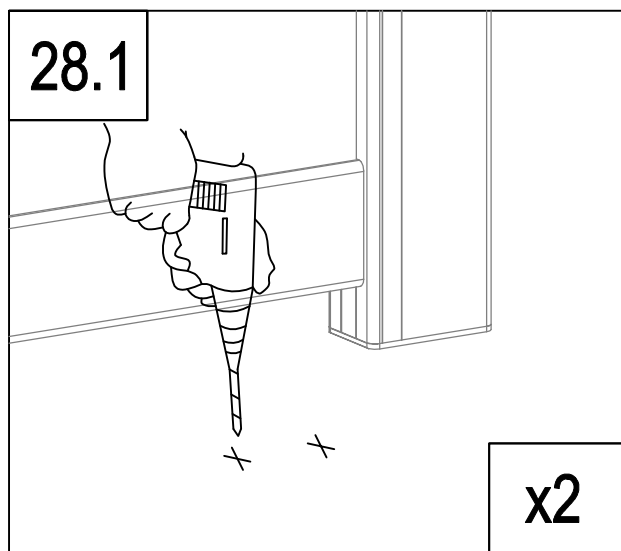
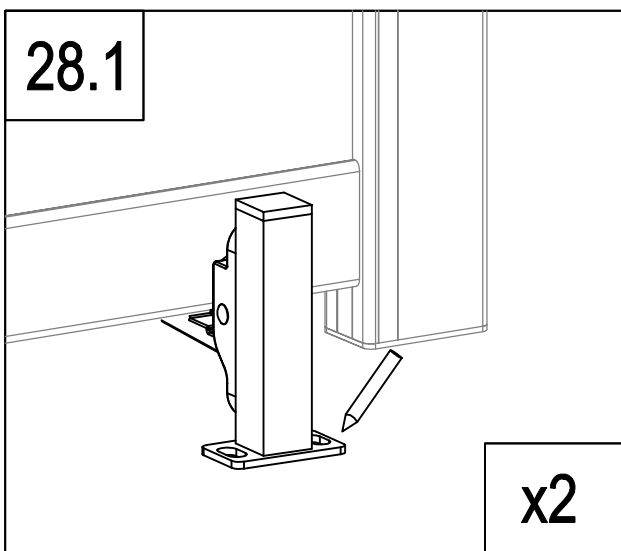
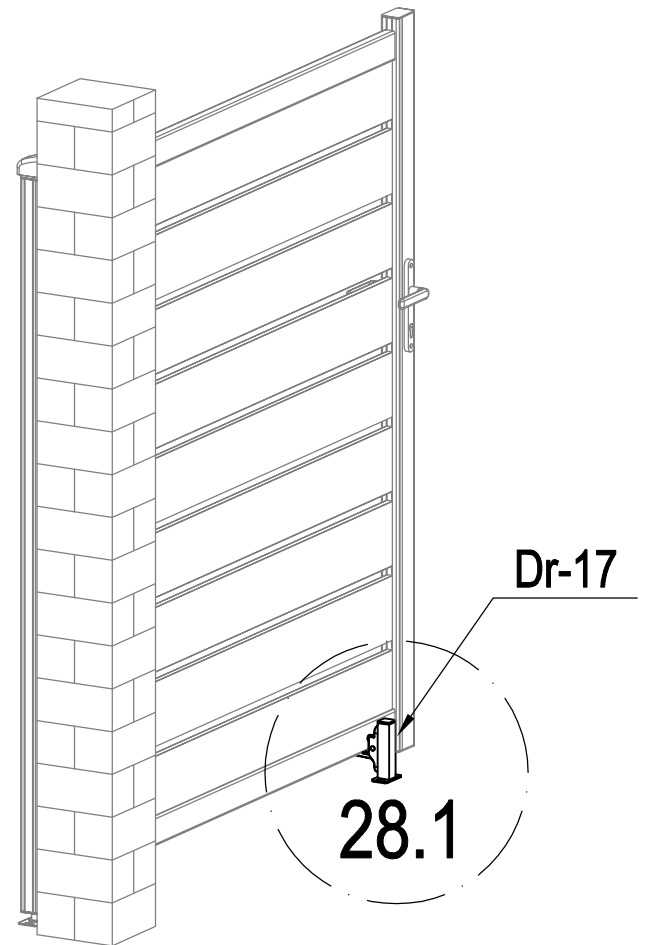
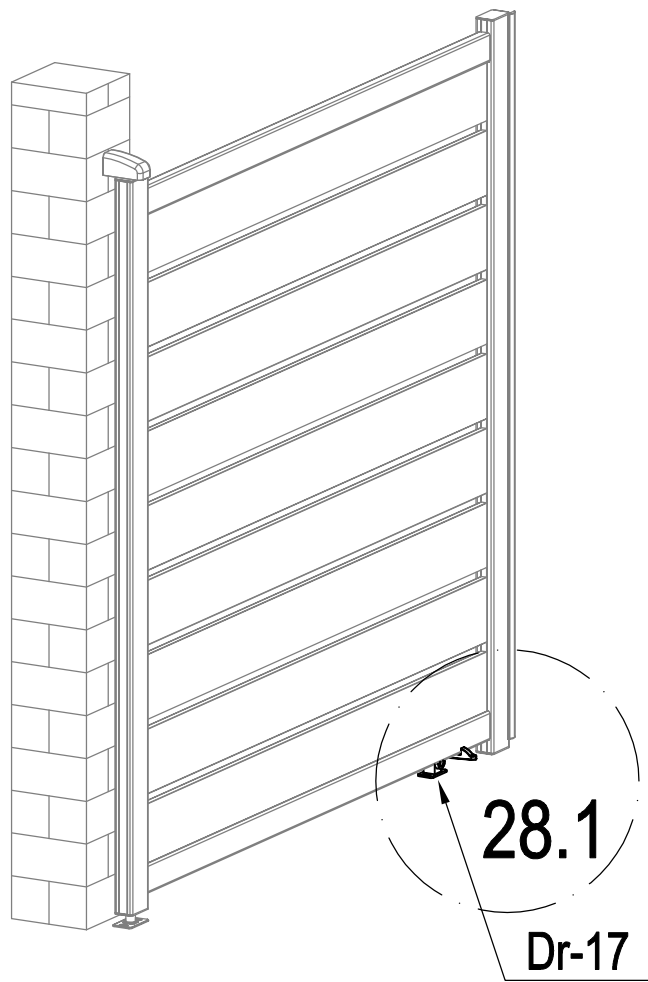



	VT-L32	4
	Dr-17	2