

ELITE 350C180

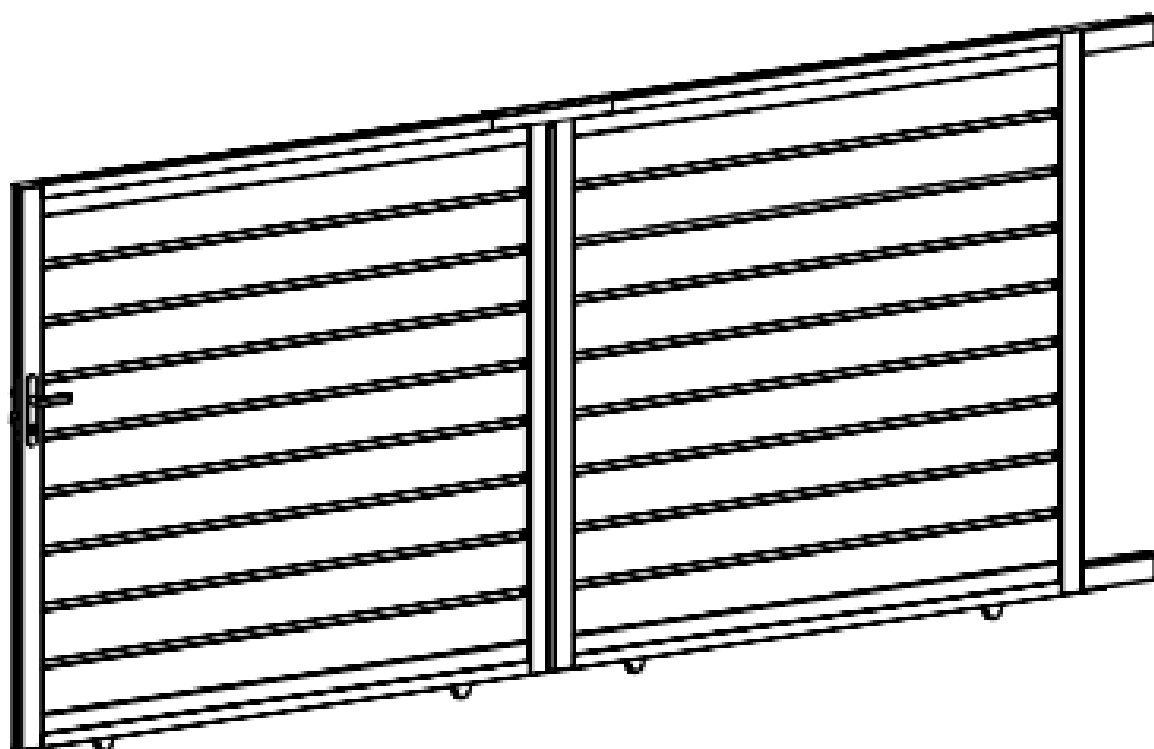

Manual de instrucciones

CE

motic

Ext.

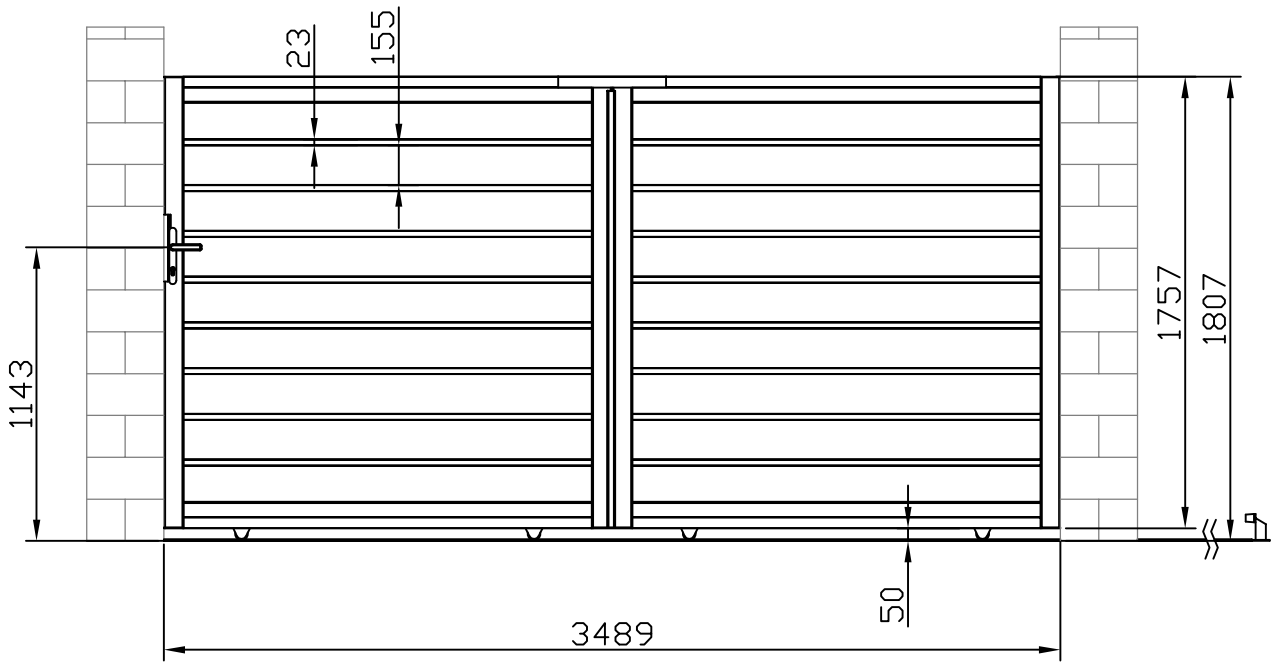

Int.

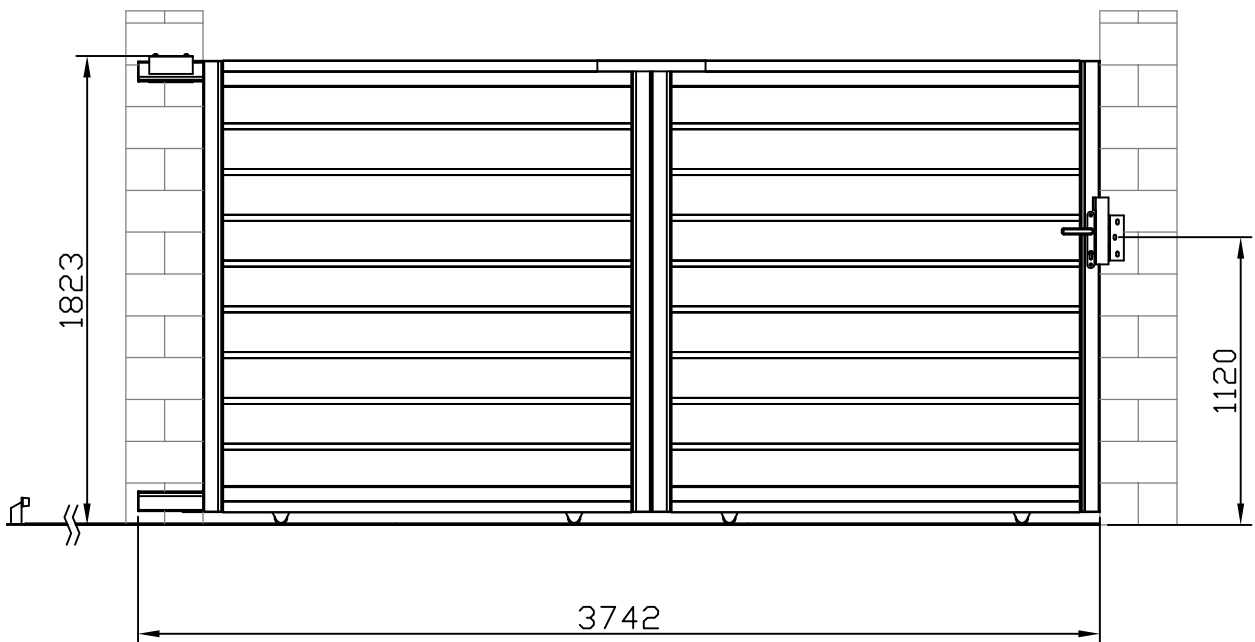

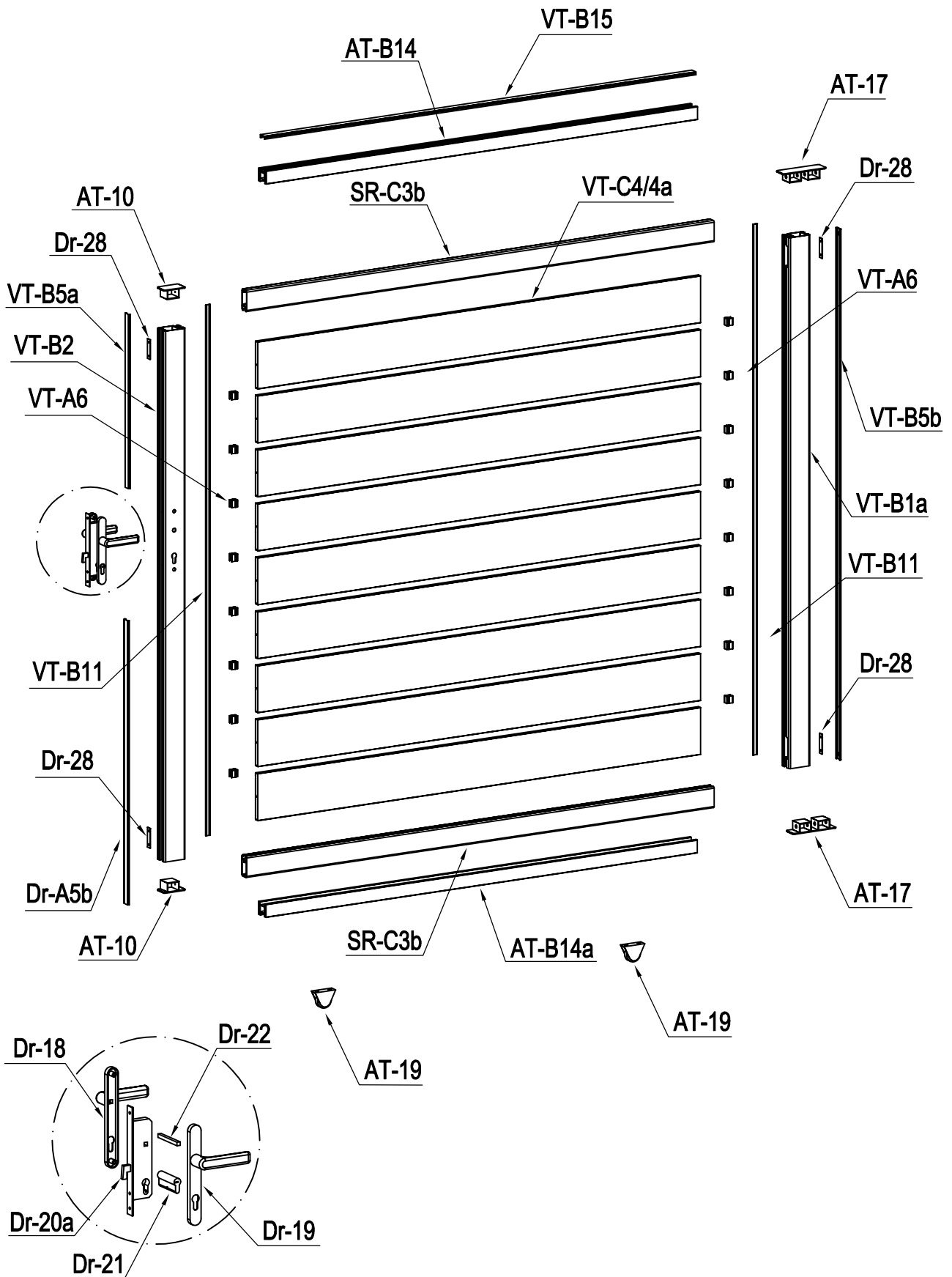

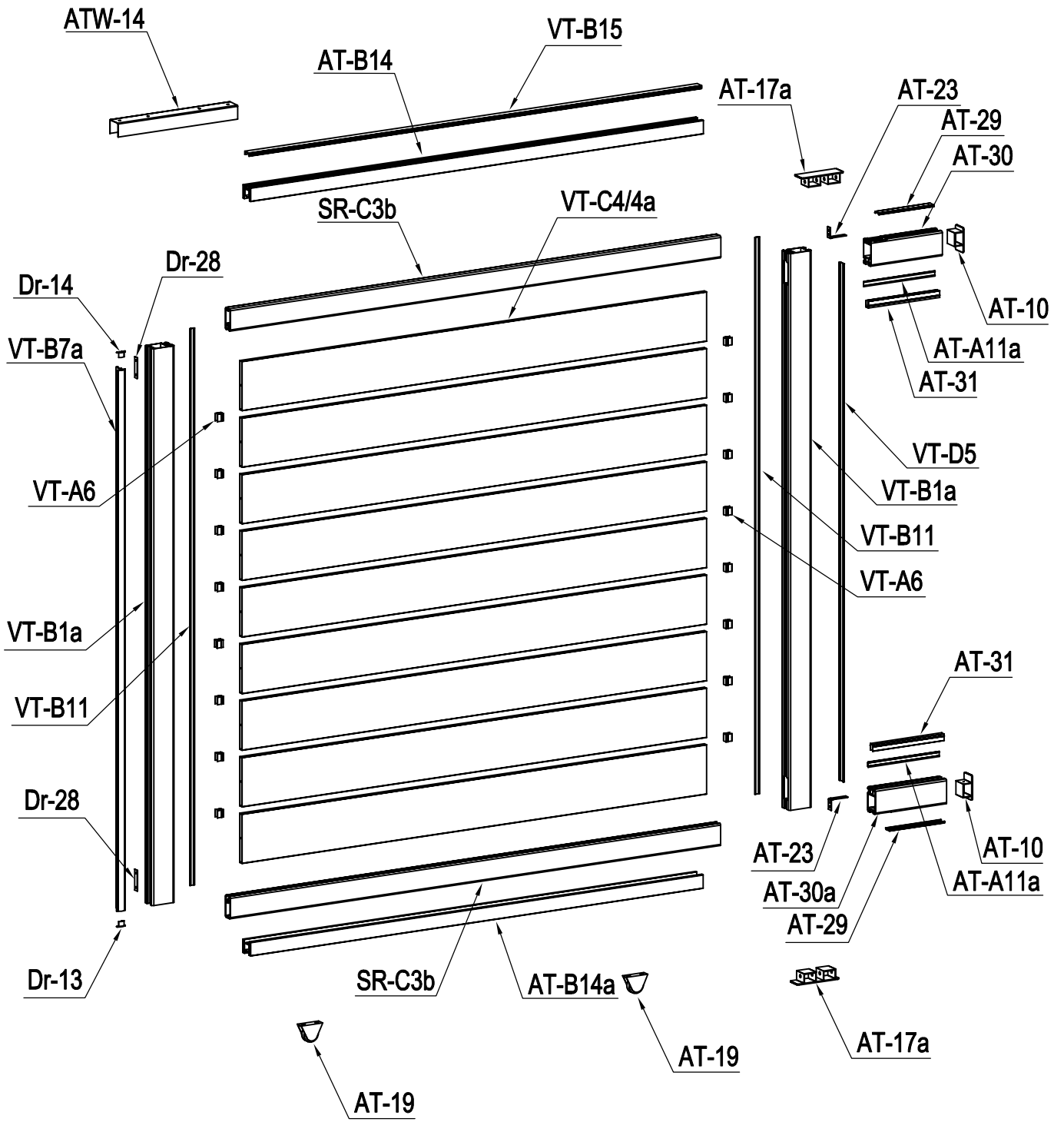

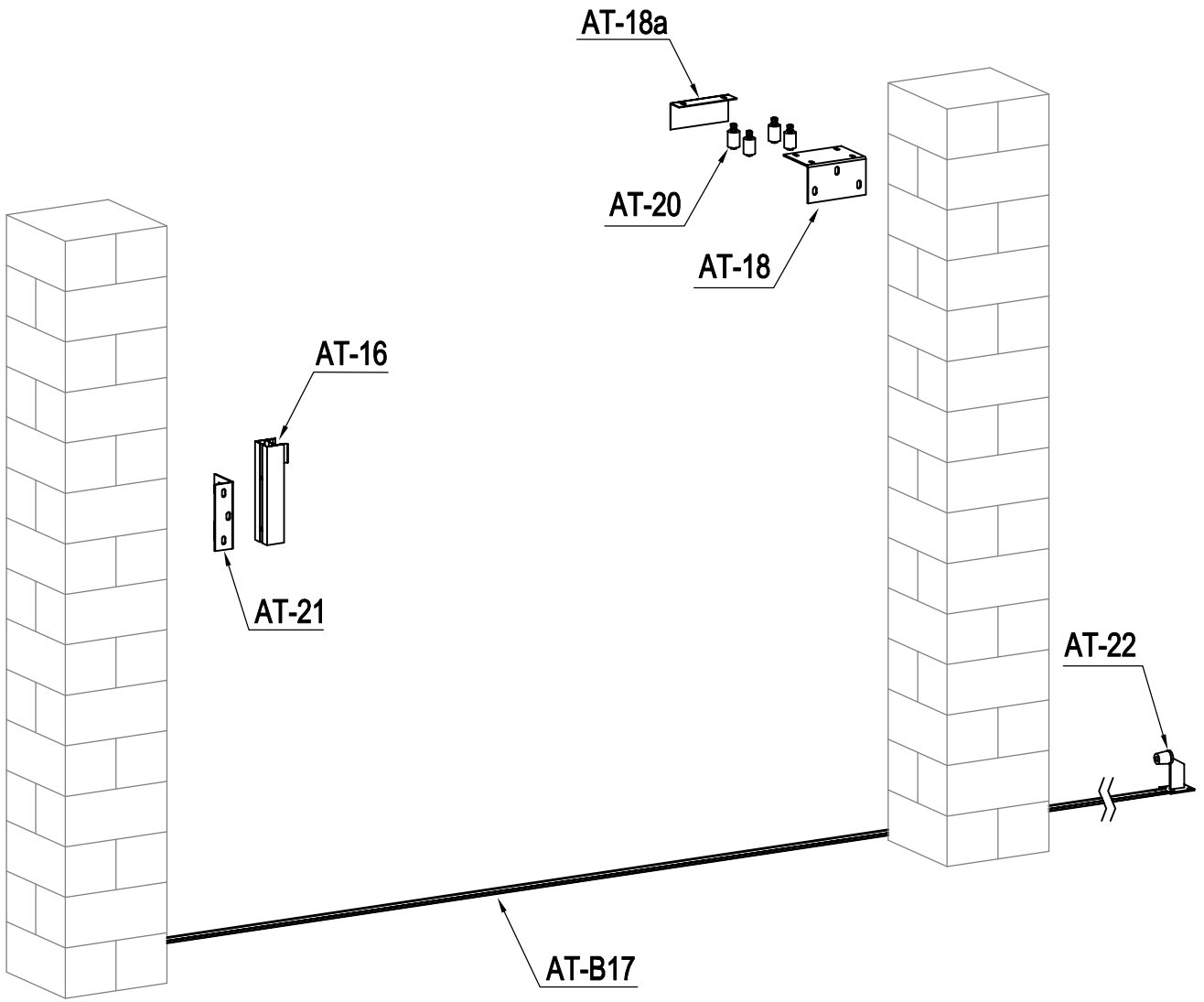









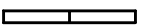





































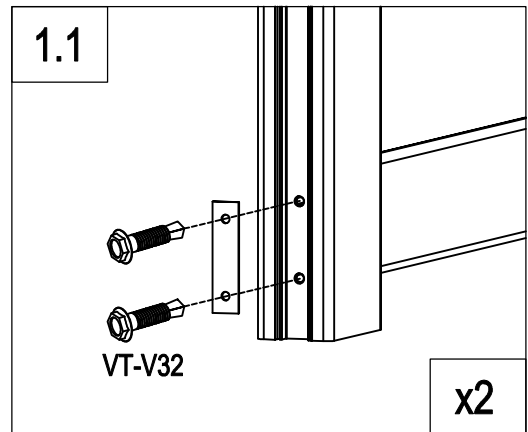
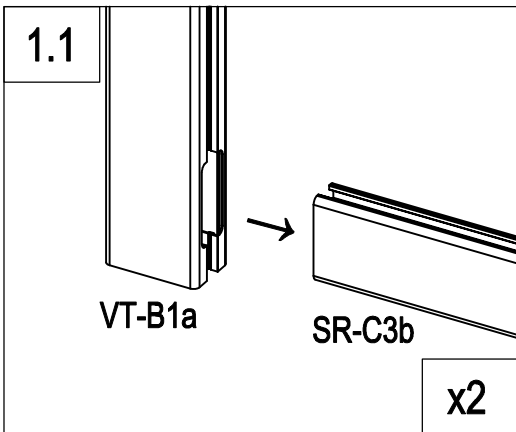
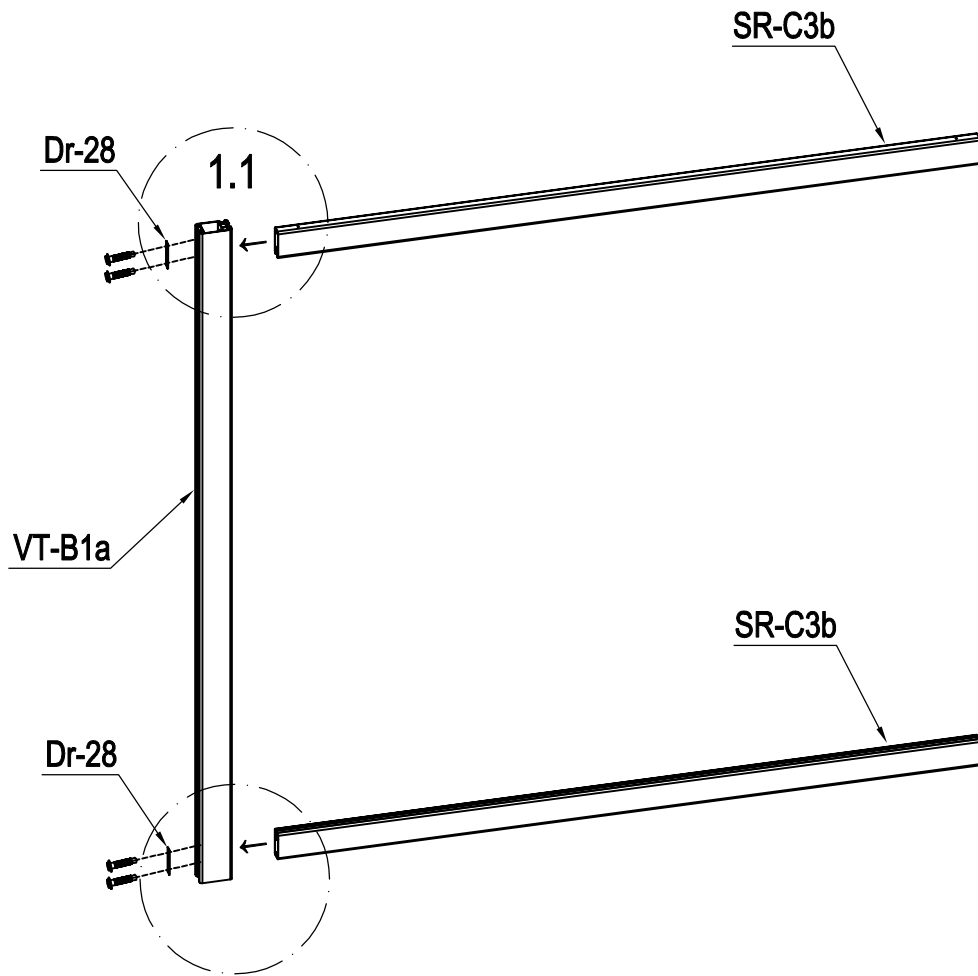

PART LIST

IMAGE	NO.	L.(mm)	QTY	IMAGE	NO.	L.(mm)	QTY
	VT-B1a	1751	3		AT-18		1
	VT-B2	1751	1		AT-18a		1
	AT-30	250	1		AT-19		4
	AT-30a	250	1		AT-20		4
	SR-C3b	1721	4		AT-21		1
	VT-C4	1630	16		AT-22		1
	VT-C4a	1630	2		AT-23		2
	VT-D5	1626	1		Dr-18		1
	VT-B5a	573.5	1		Dr-19		1
	Dr-A5b	937	1		Dr-20a		1
	VT-B5b	1751	1		Dr-21		1
	AT-29	193	2		Dr-22		1
	VT-B11	1751	4		Dr-25		1
	AT-A11a	250	2		Dr-25a		2
	VT-A6	23	32		Dr-27		2
	AT-31	250	2		VT-V30		4
	VT-B7a	1698	1		VT-V31		10
	AT-B14	1588	2		VT-V32		32
	AT-B14a	1588	2		VT-V33		4
	VT-B15	1587	2		VT-V34		76
	AT-16	260	1		VT-V35		6
	AT-B17	1412	5		VT-V36		2
	AT-17		2		VT-V37		8
	AT-17a		2		VT-V38		50
	AT-10		4		Dr-28		6
	Dr-13		1		AT-22J		7
	Dr-14		1		ATW-14		1

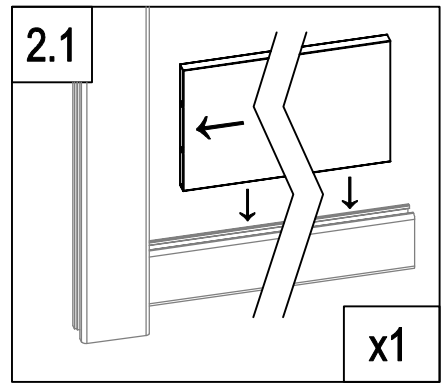
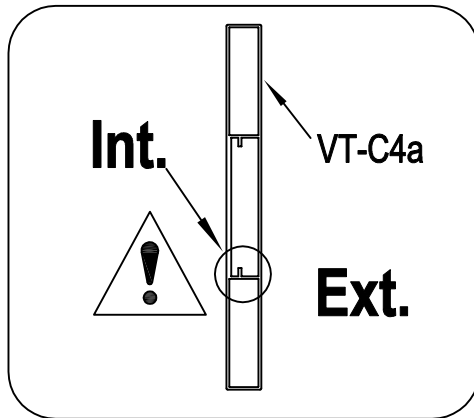
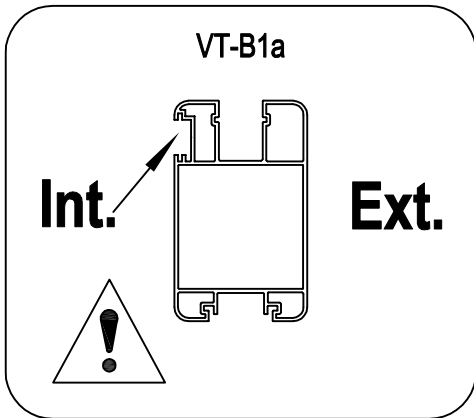
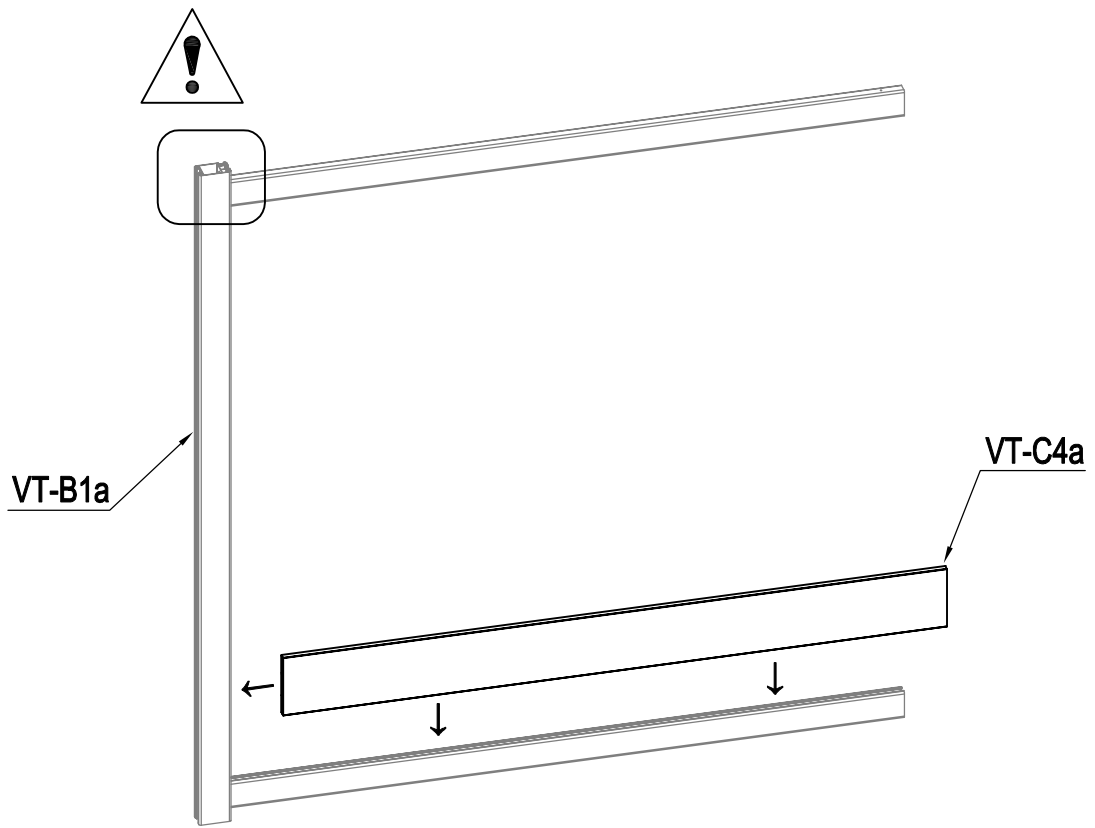

	VT-B1a	1
	SR-C3b	2
	Dr-28	2
	VT-V32	4



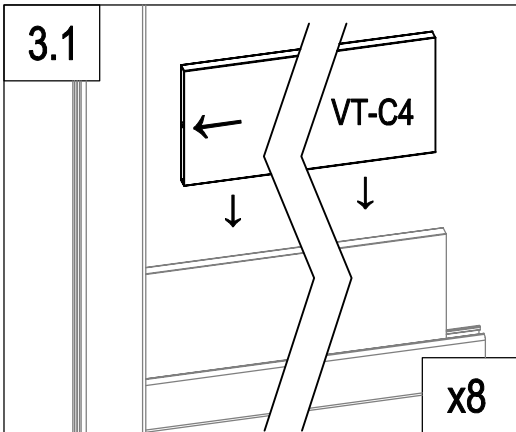
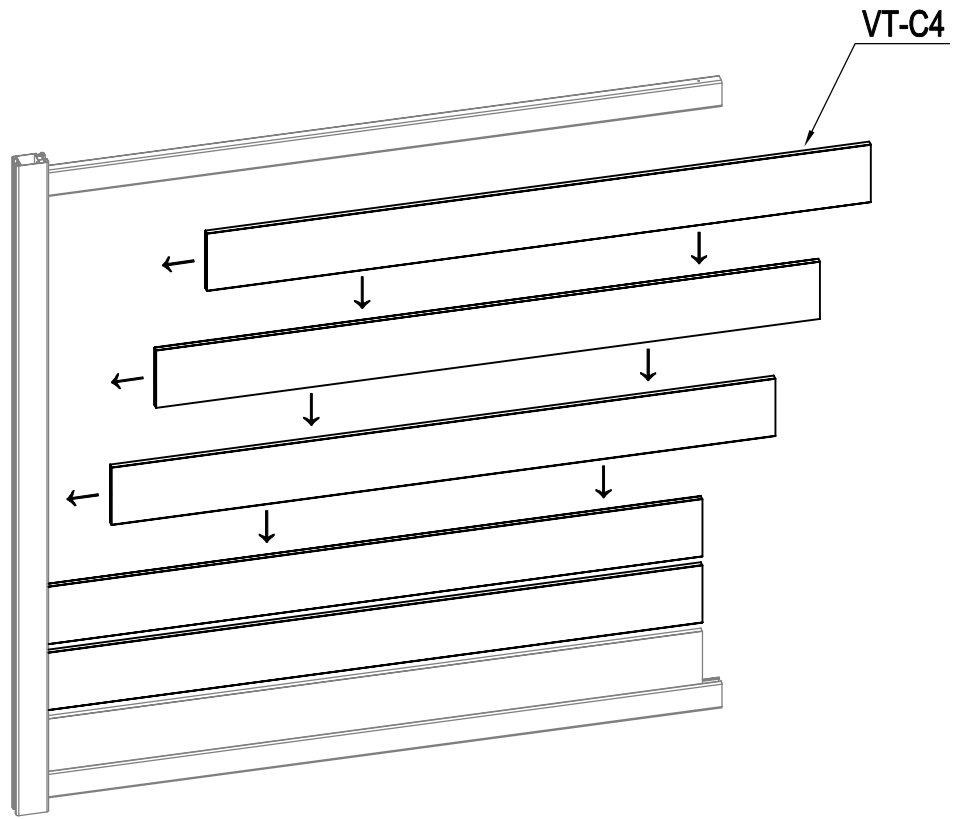

	VT-C4a	1
---	--------	---

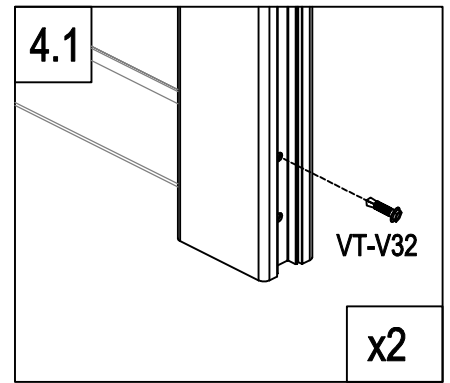
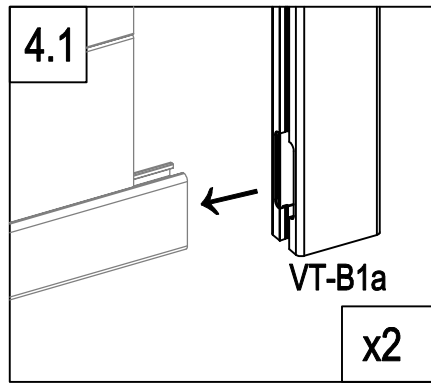
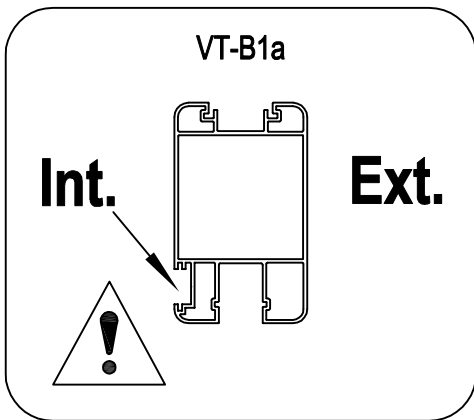
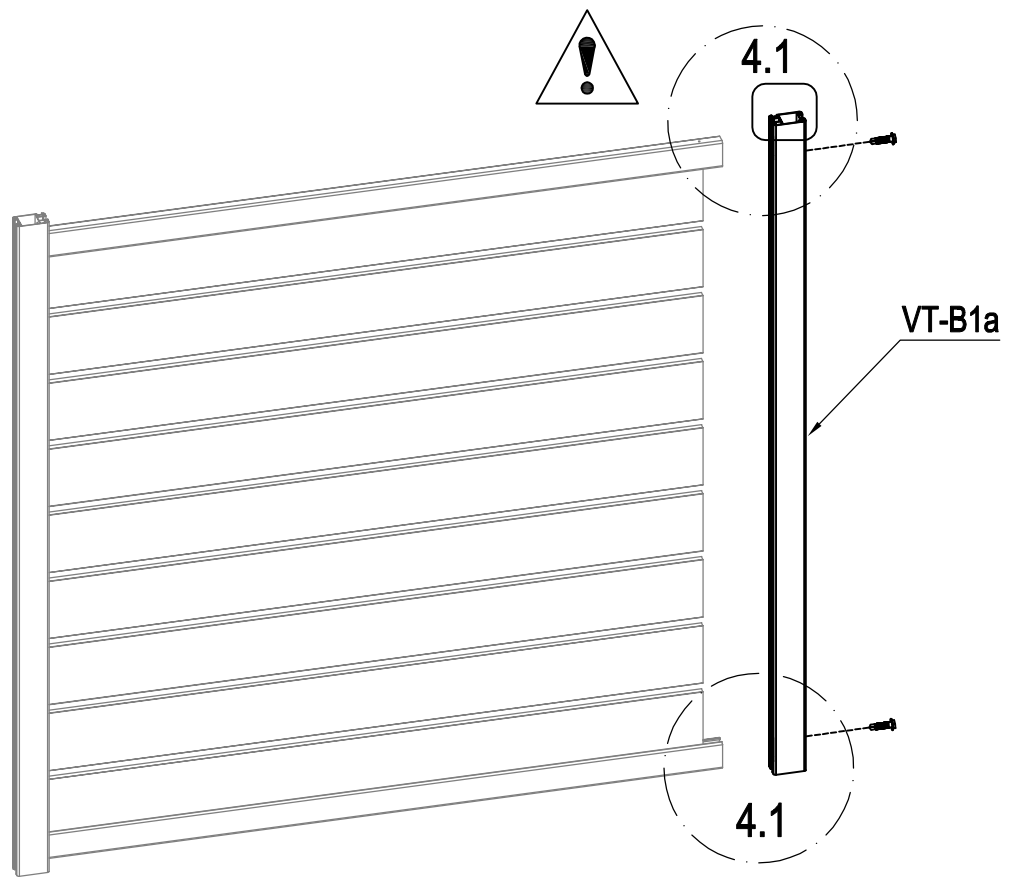

	VT-C4	8
---	-------	---



	VT-B1a	1
	VT-V32	2

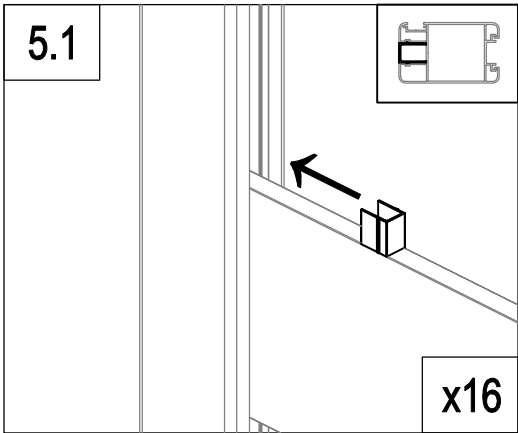
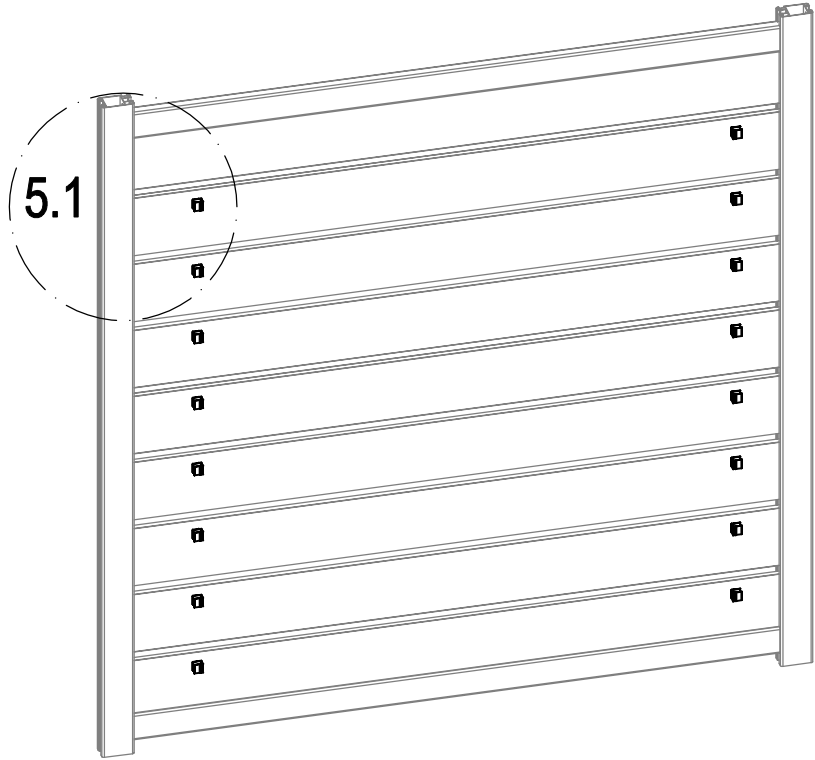

	VT-A6	16
---	-------	----

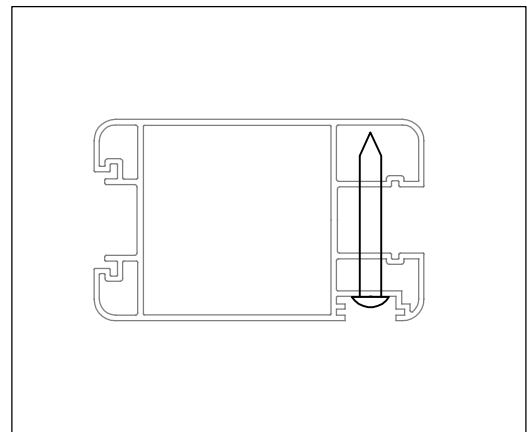
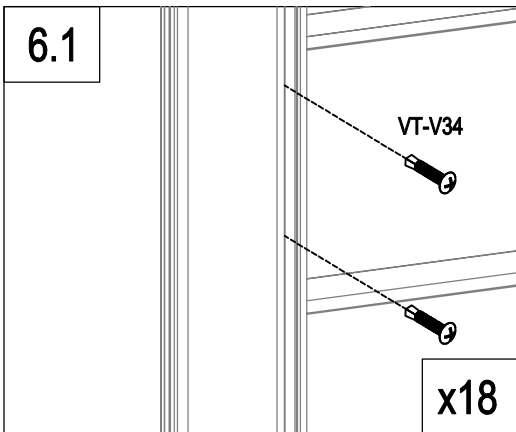
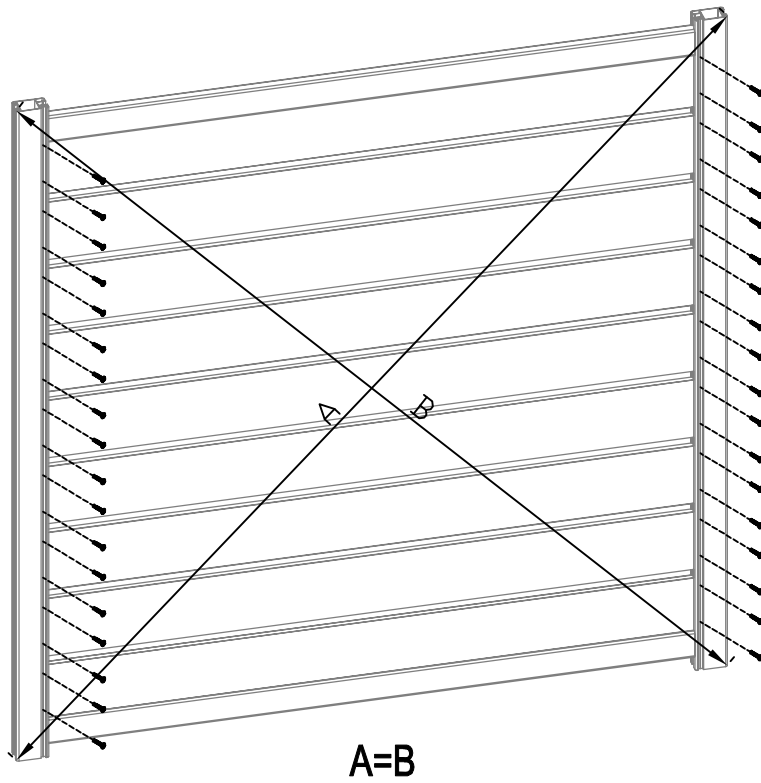

	VT-V34	36
---	--------	----

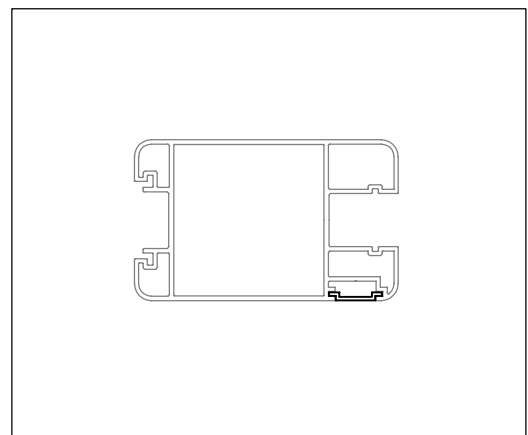
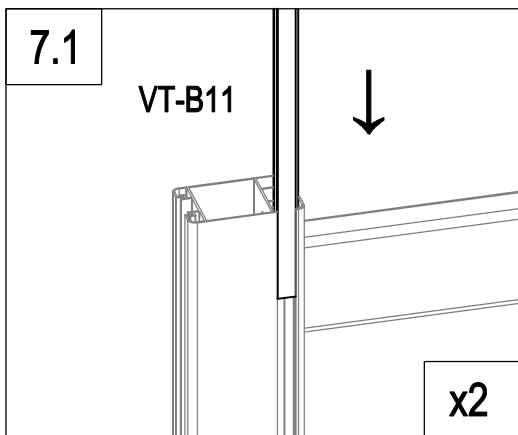
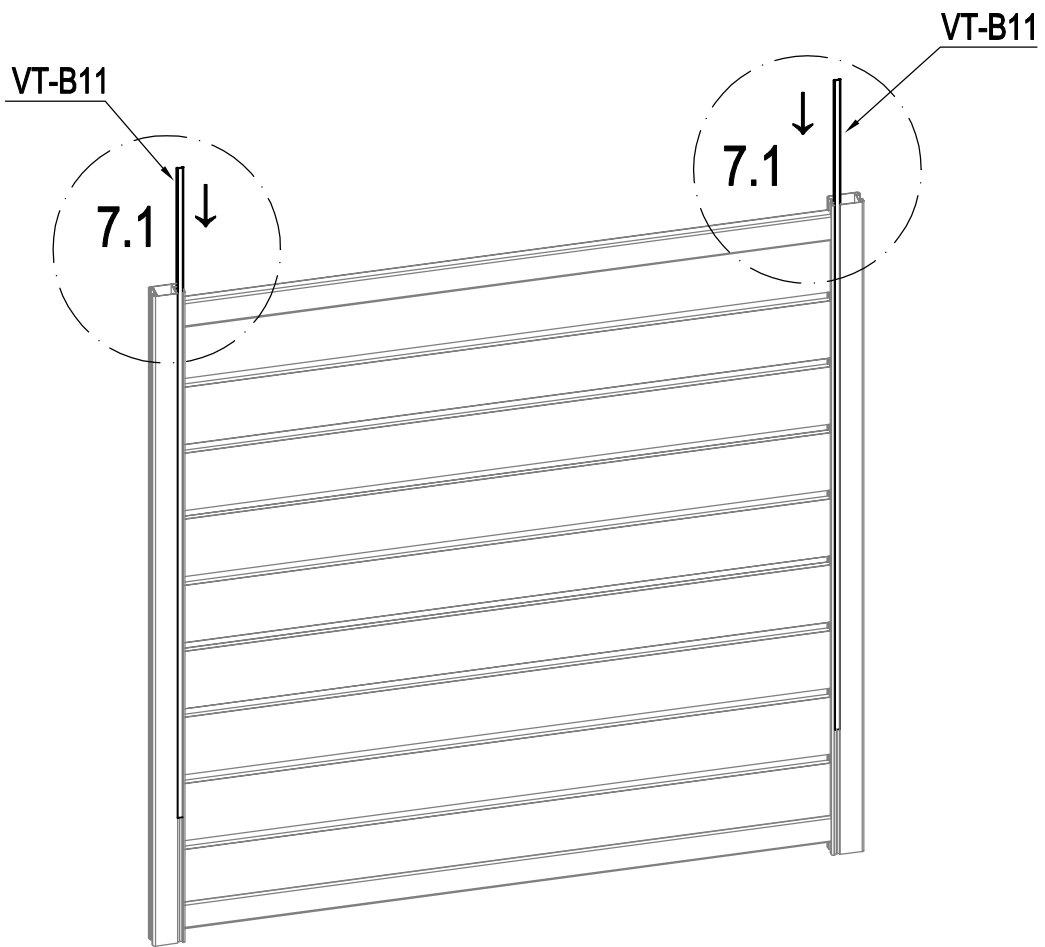

	VT-B11	2
---	--------	---

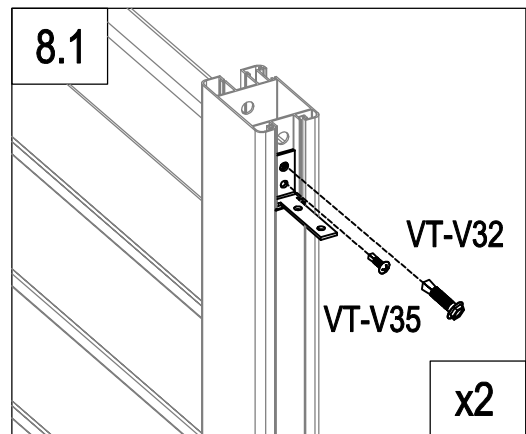
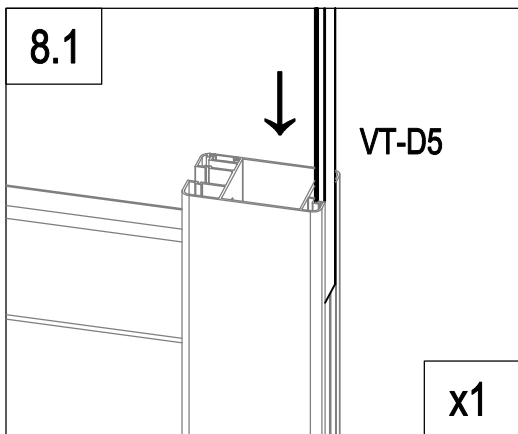
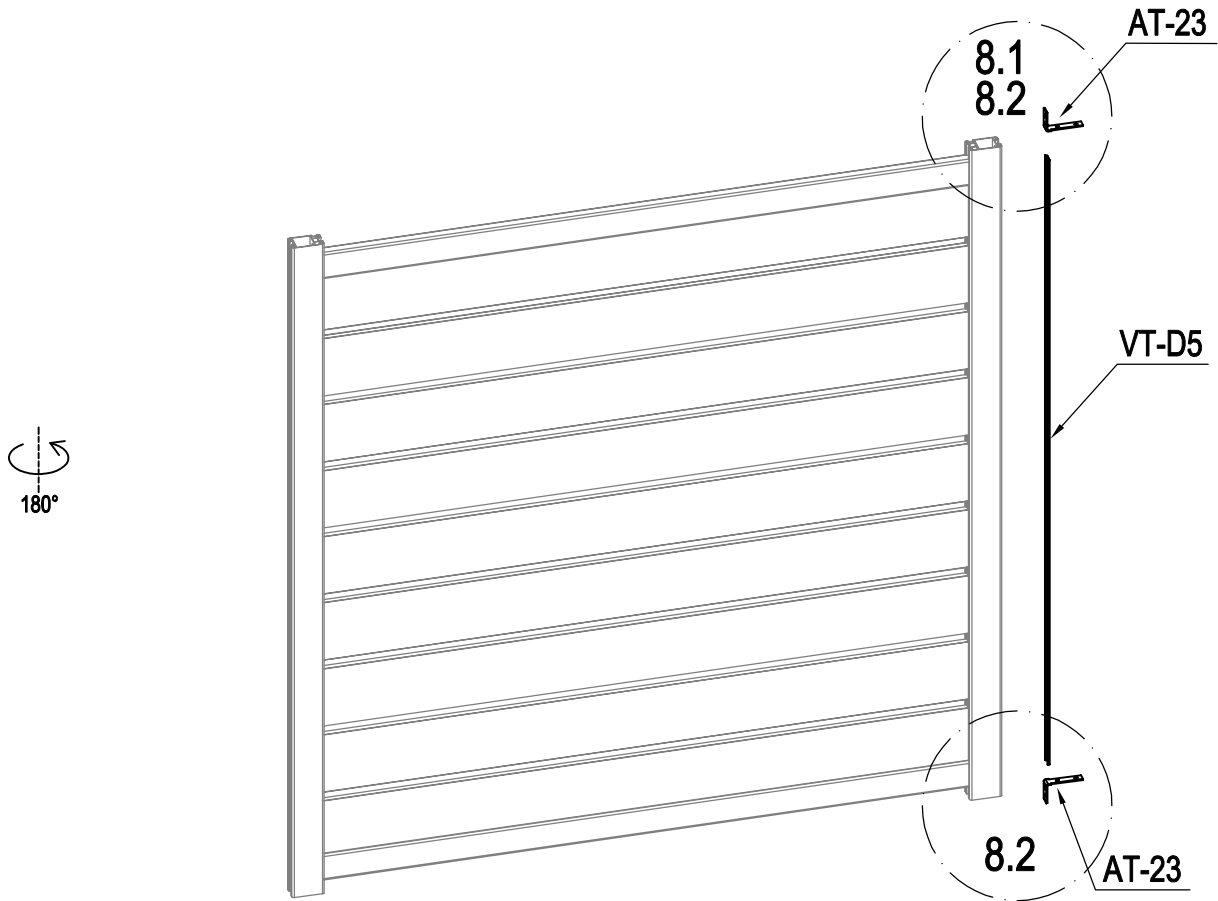

	VT-D5	1
	AT-23	2
	VT-V32	2
	VT-V35	2

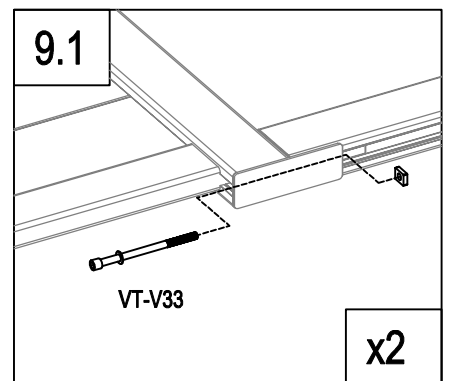
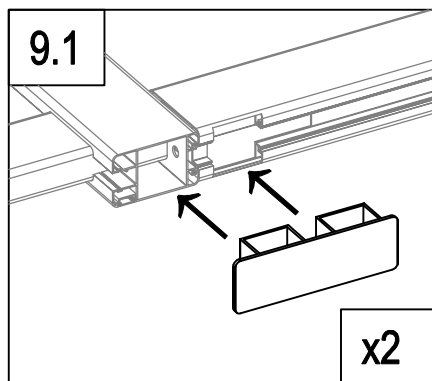
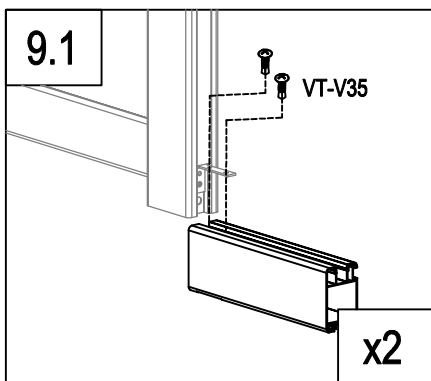
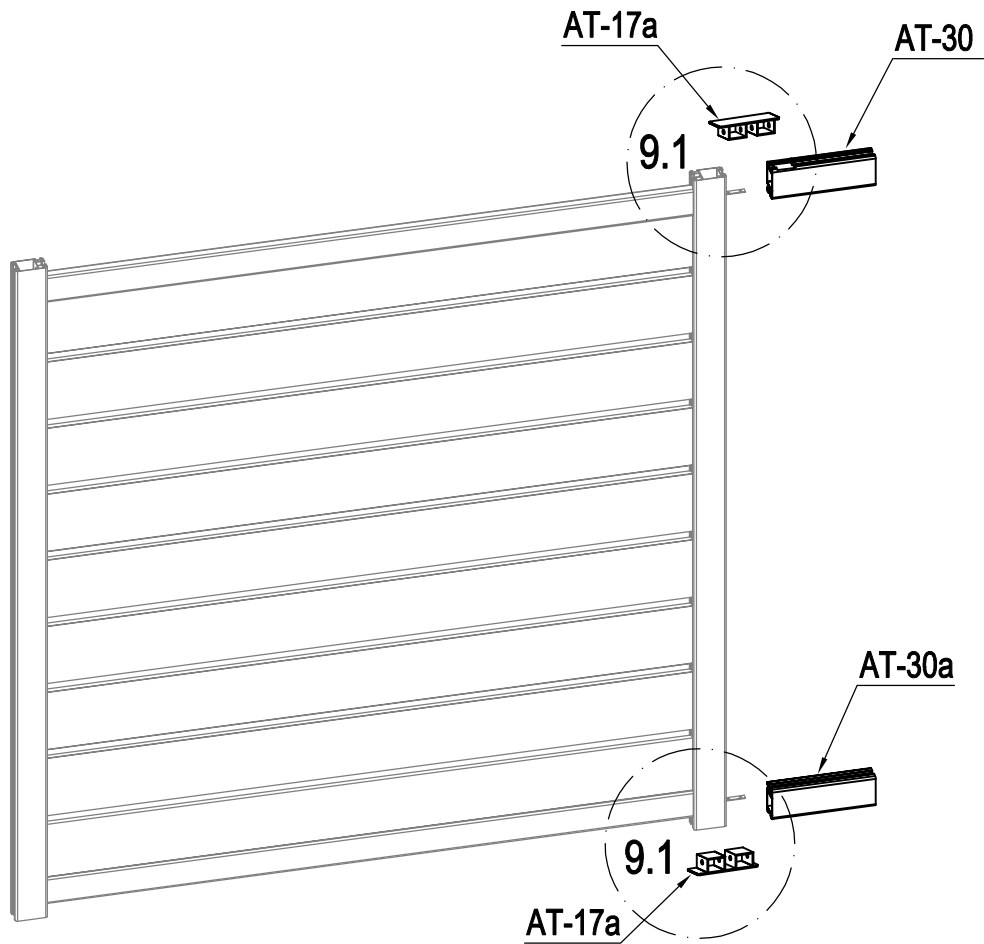

	AT-30	1
	AT-30a	1
	AT-17a	2

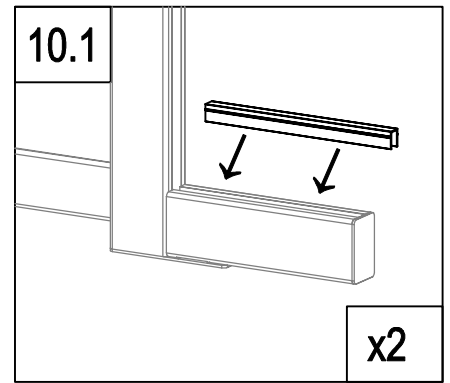
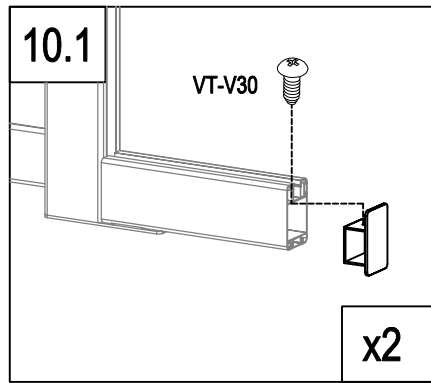
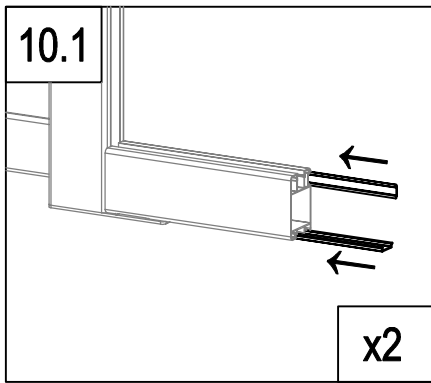
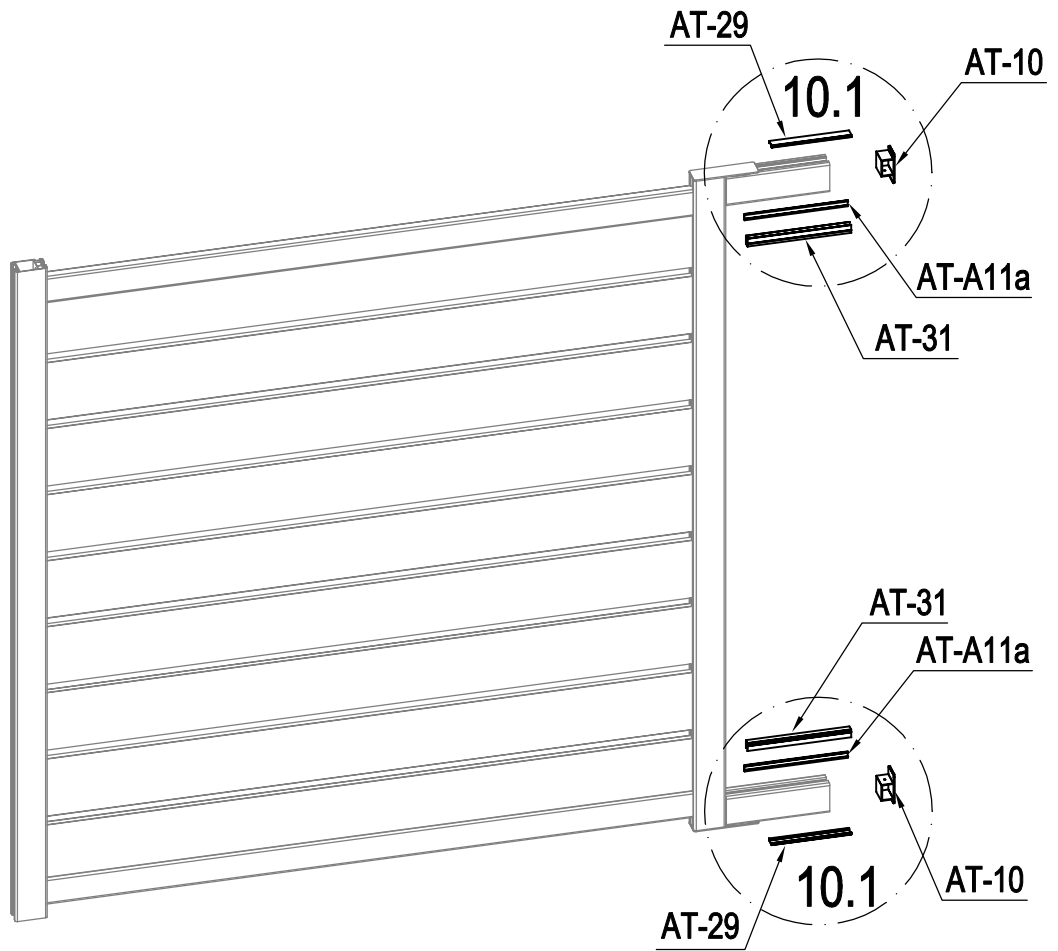

	VT-V33	2
	VT-V35	4





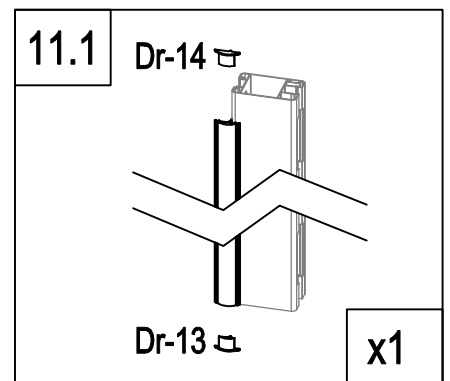
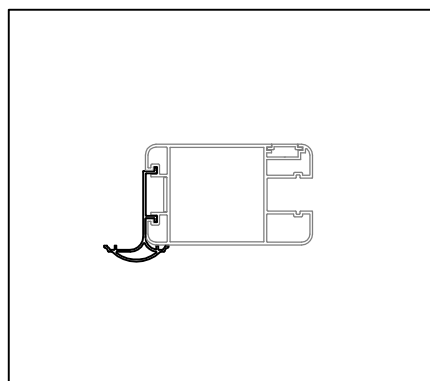
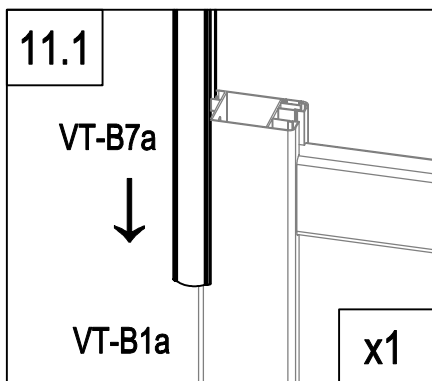
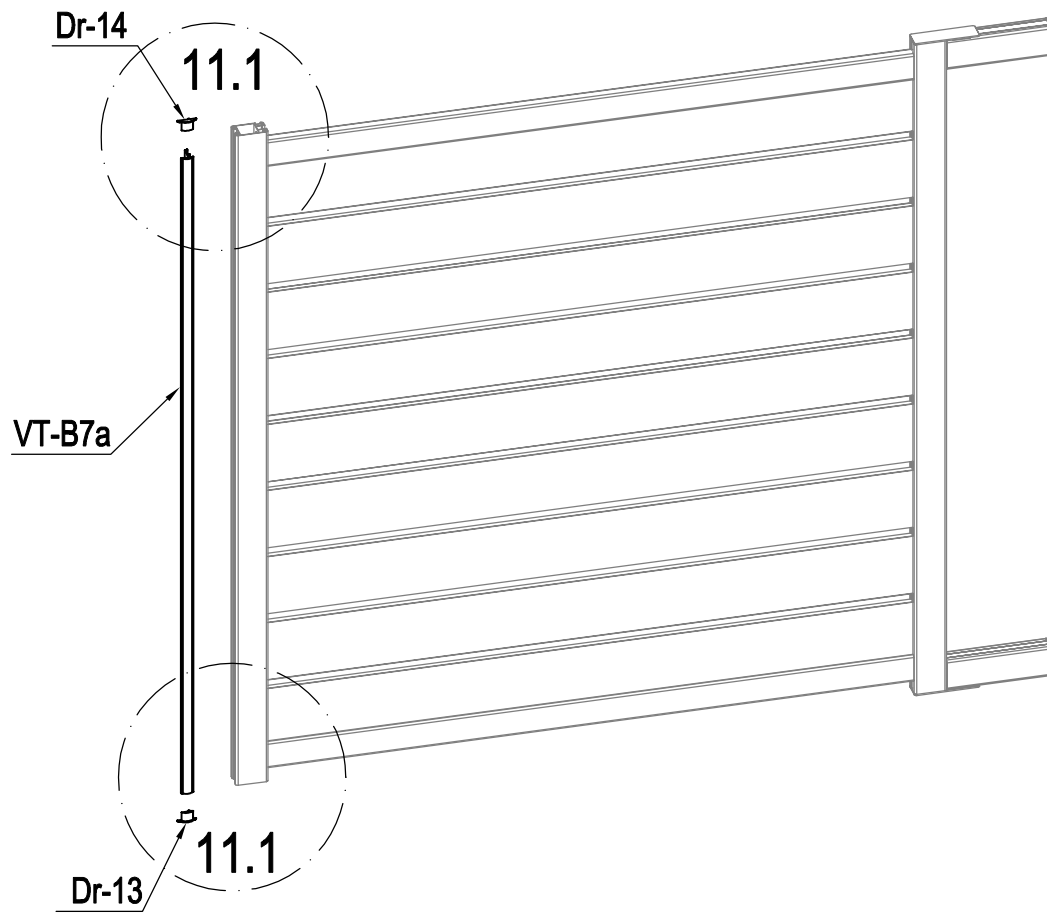

	AT-29	2
	AT-A11a	2
	AT-31	2

	AT-10	2
	VT-V30	2

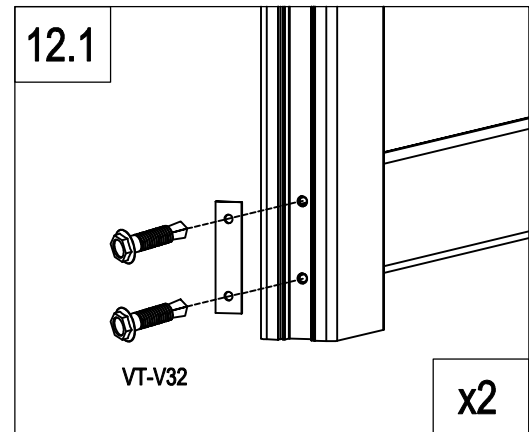
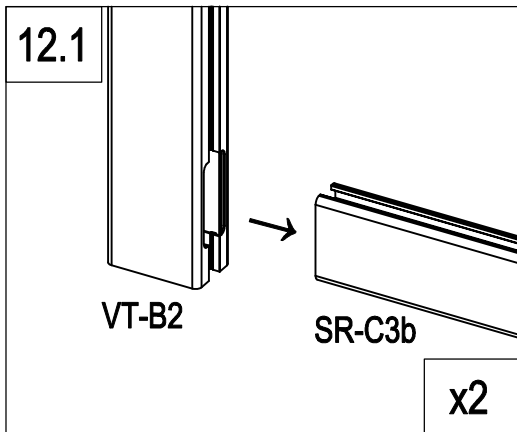
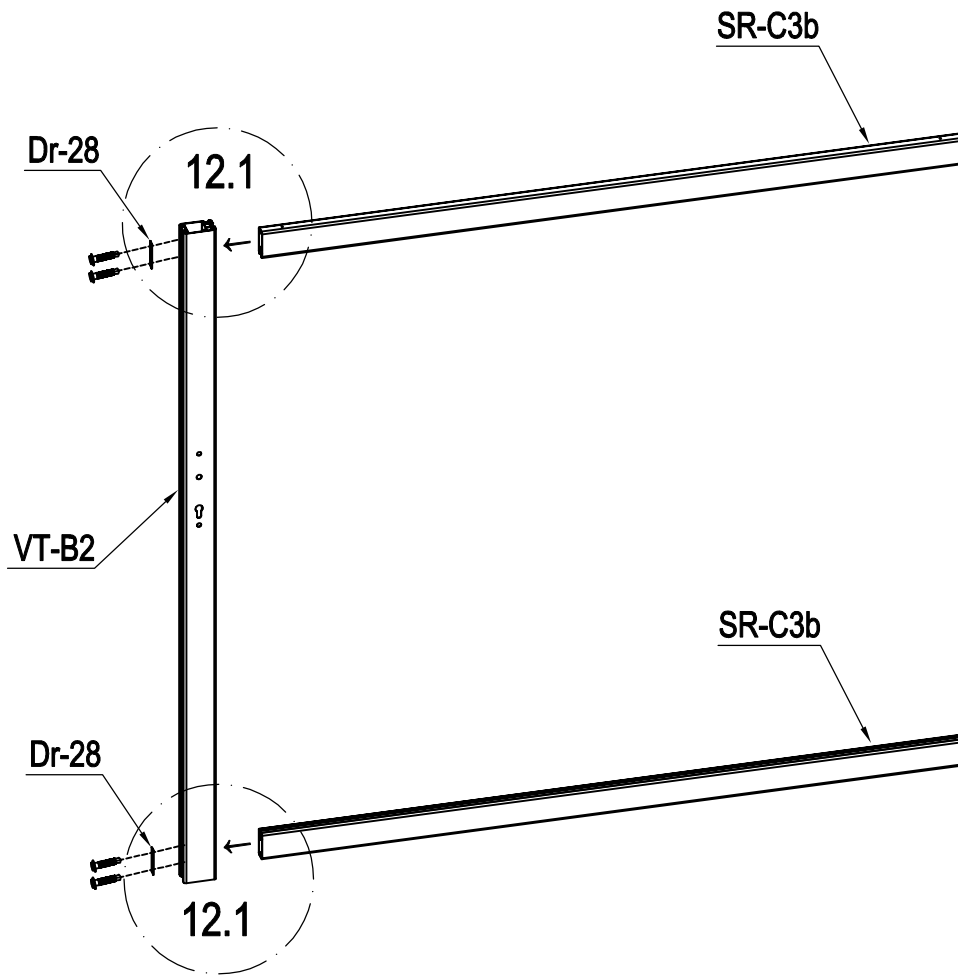

	VT-B7a	1
	Dr-13	1
	Dr-14	1



	VT-B2	1
	SR-C3b	2
	Dr-28	2
	VT-V32	4

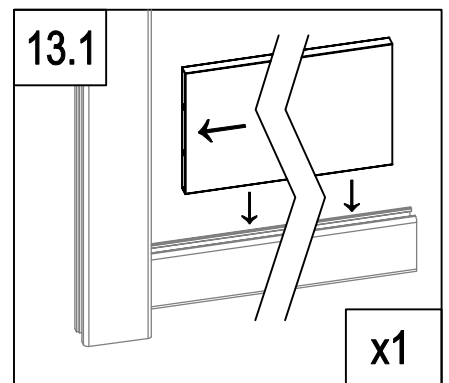
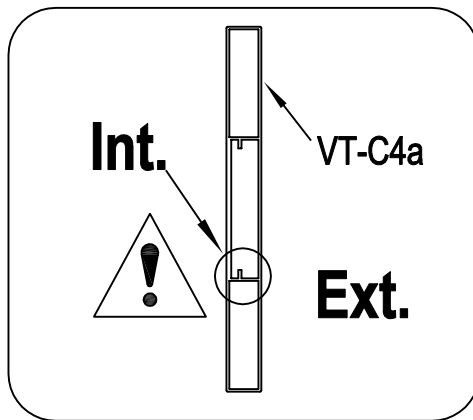
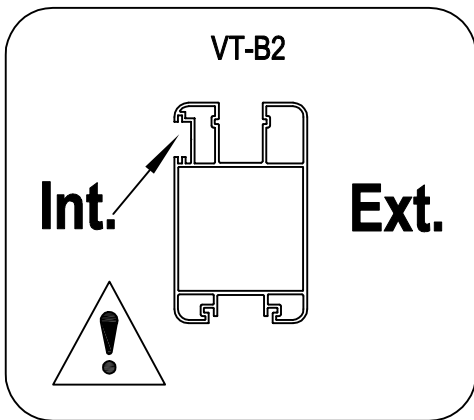
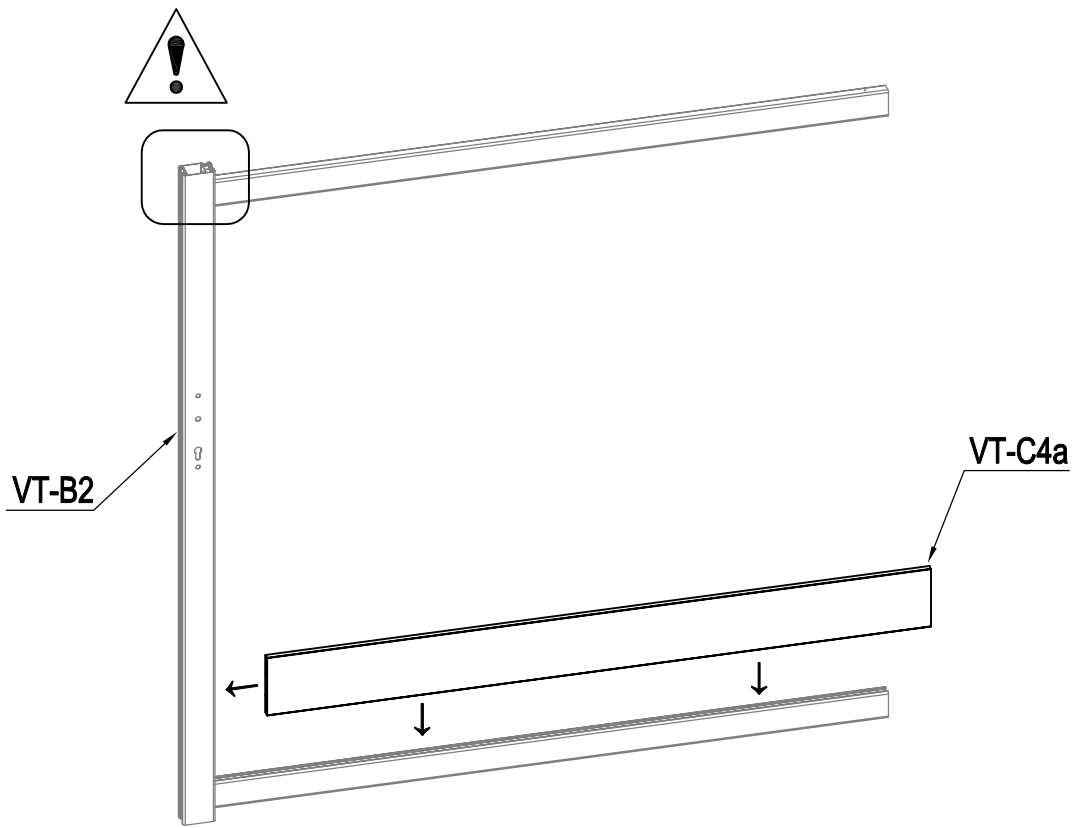

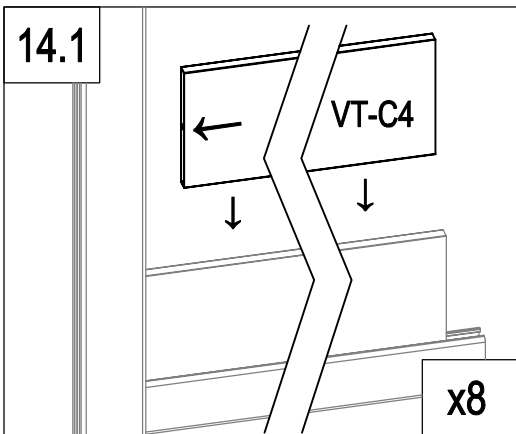
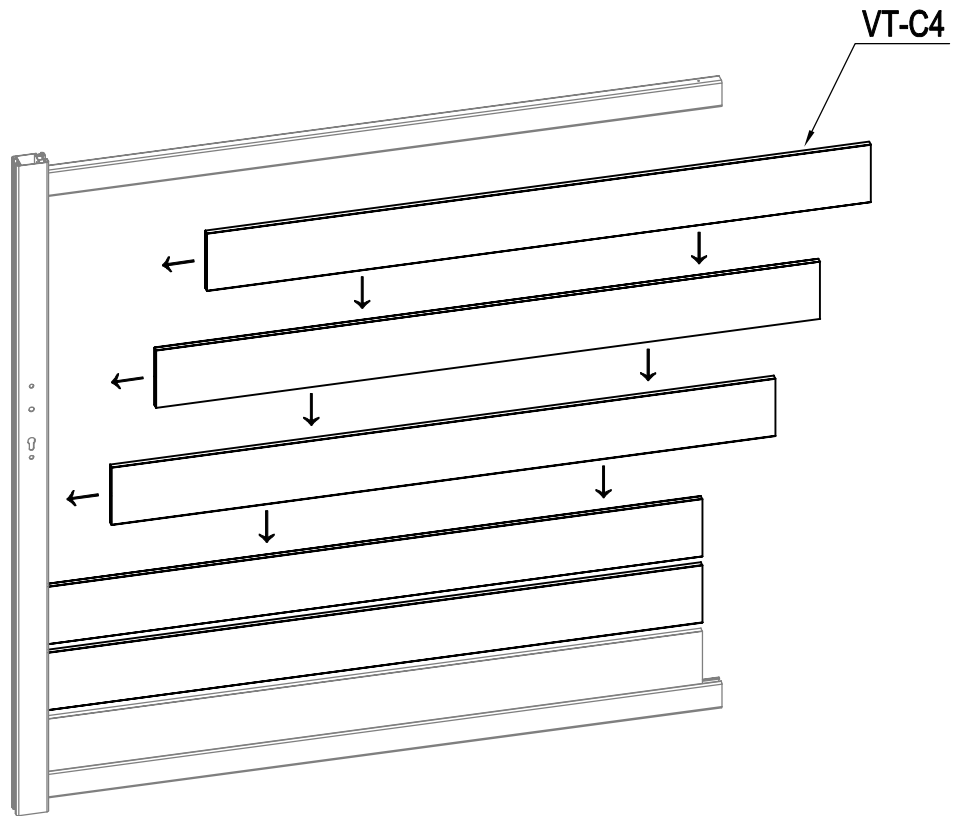

	VT-C4a	1
---	--------	---

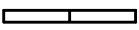

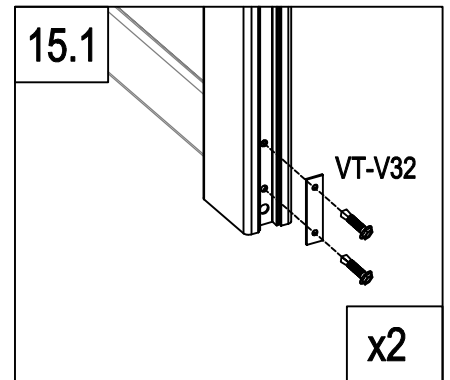
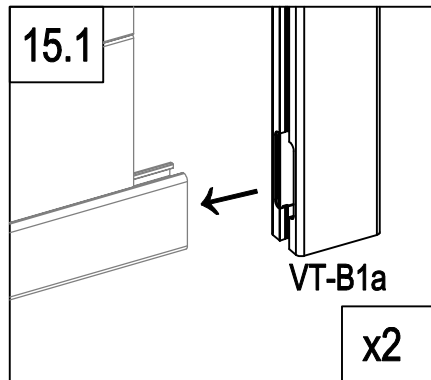
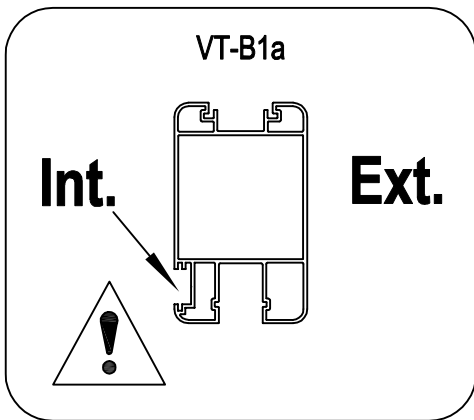
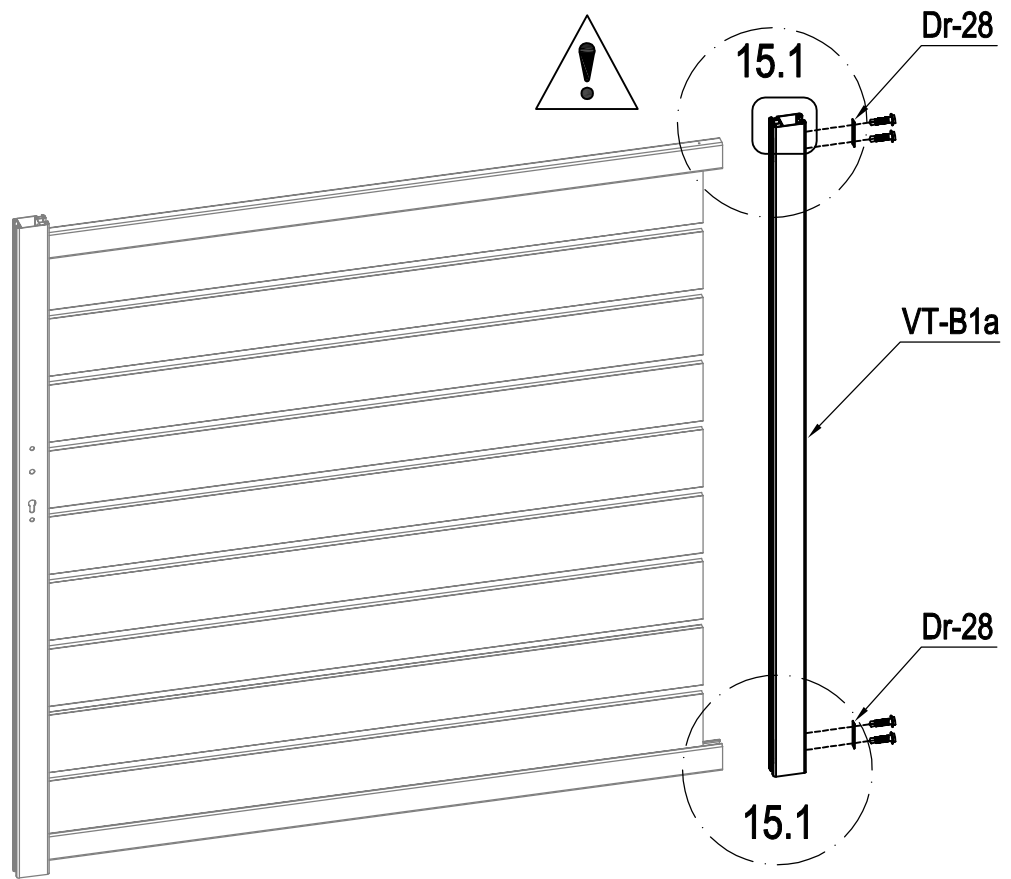
	VT-C4	8
---	-------	---



	VT-B1a	1
	Dr-28	2
	VT-V32	4

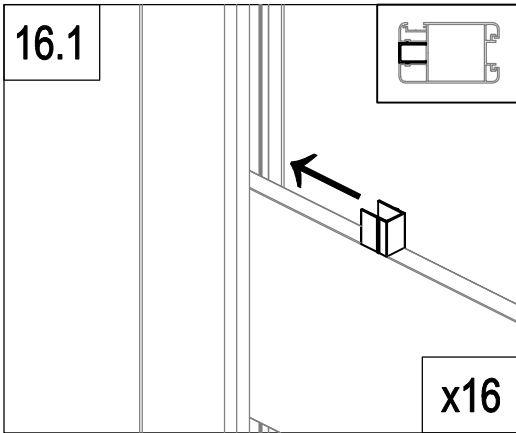
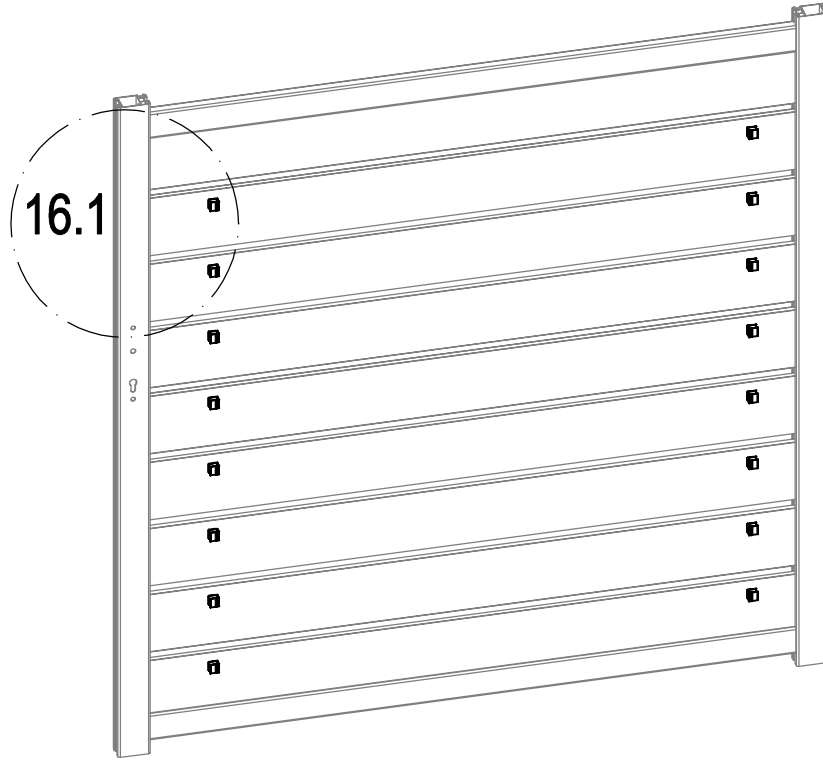

	VT-A6	16
---	-------	----

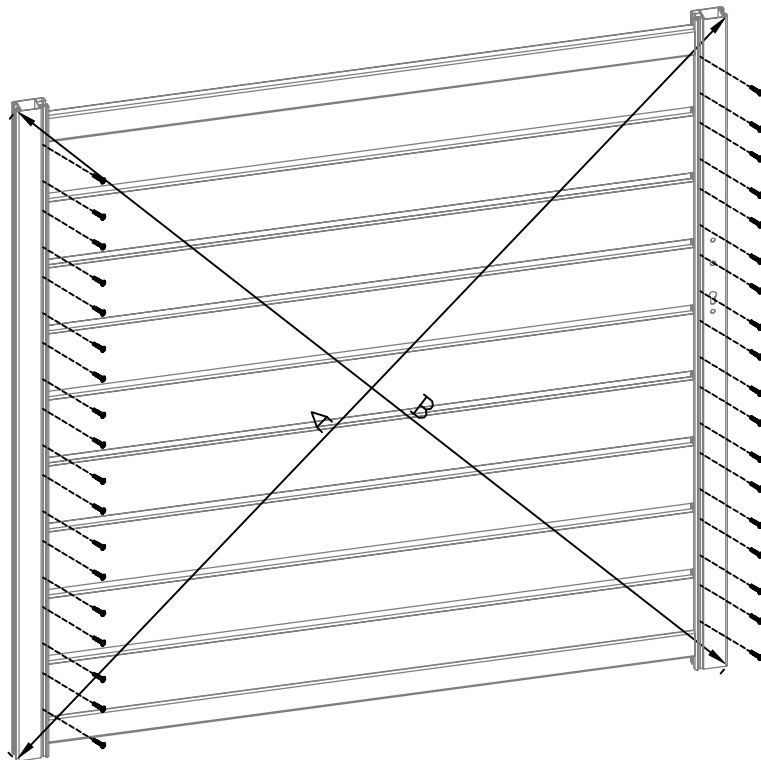
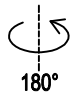

A=B

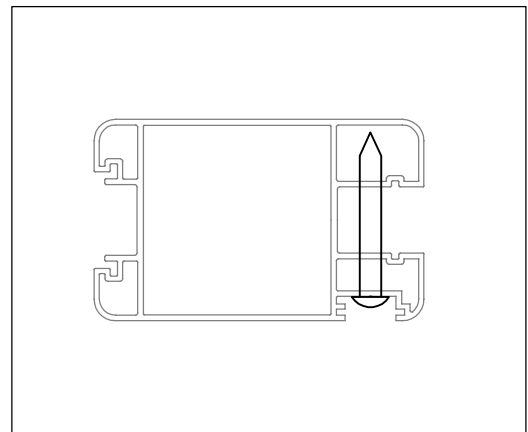
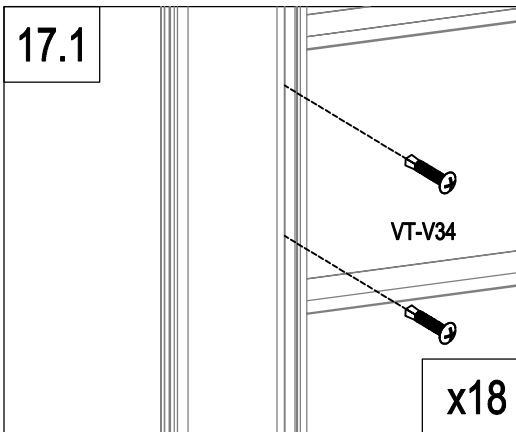

	VT-V34	36
---	--------	----

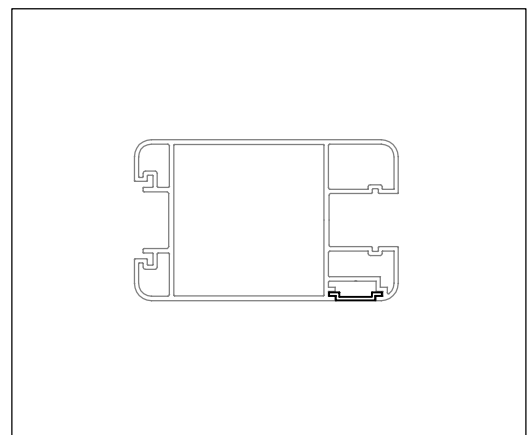
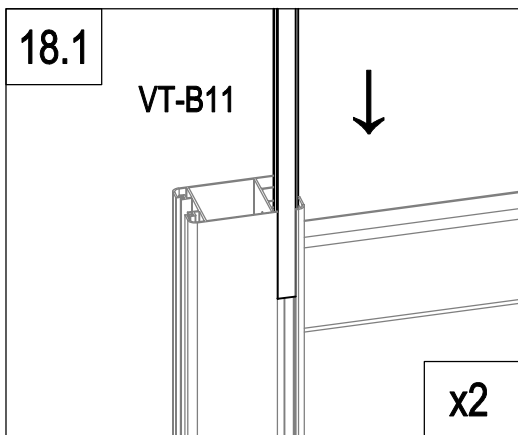
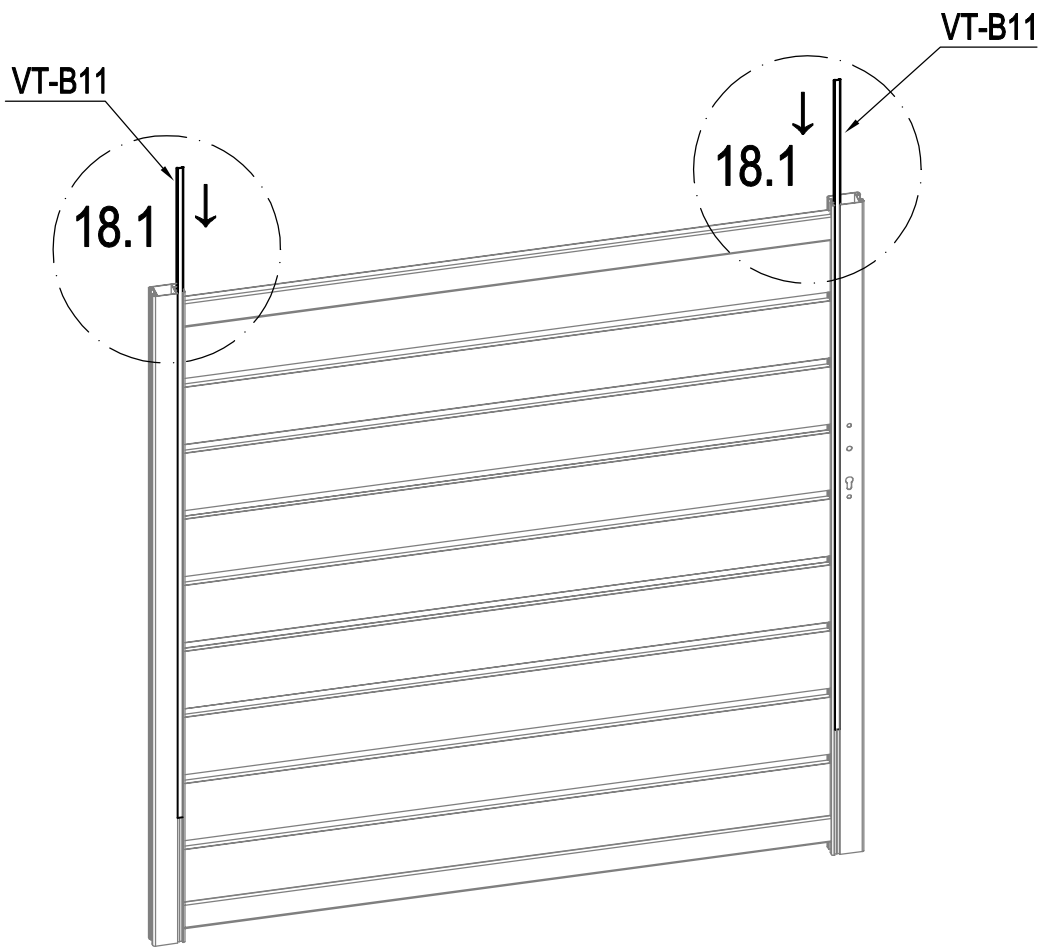

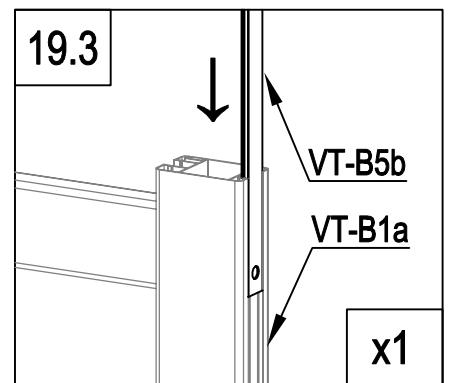
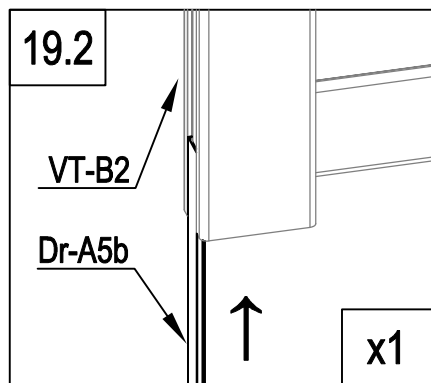
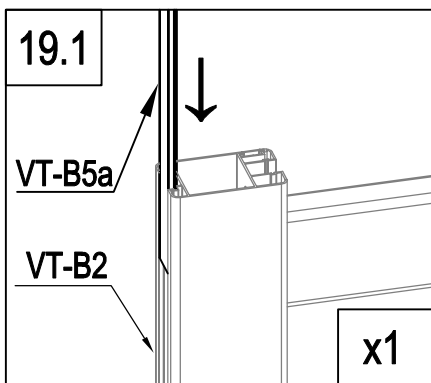
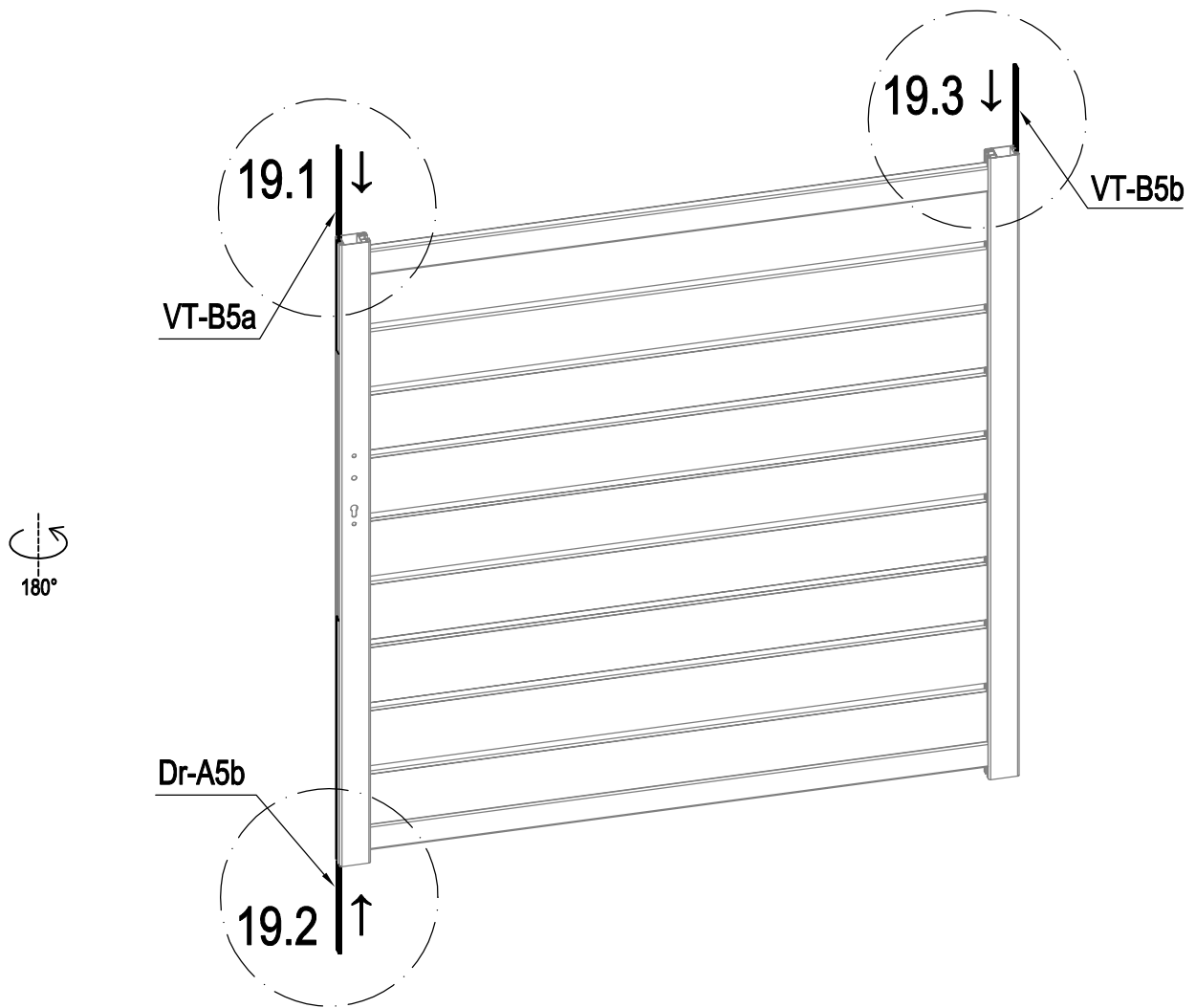

	VT-B11	2
---	--------	---



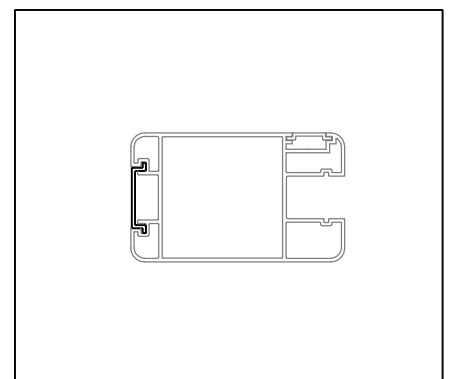

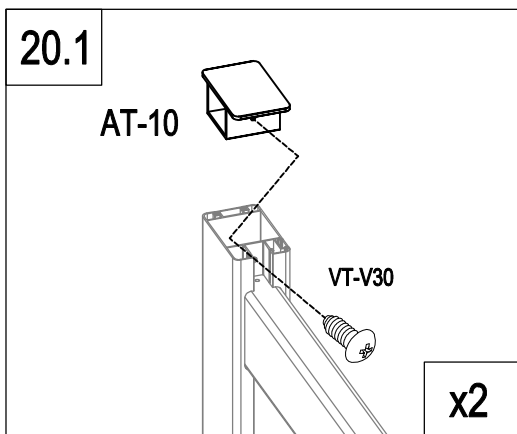
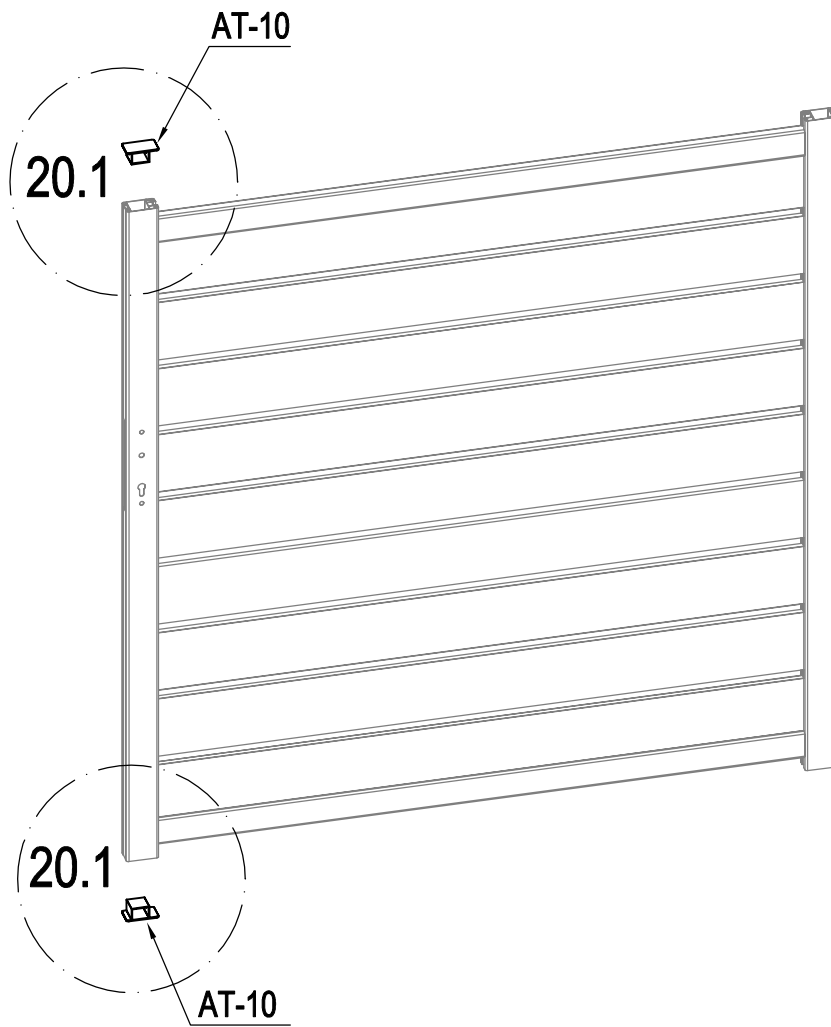
	VT-B5b	1
	VT-B5a	1
	Dr-A5b	1



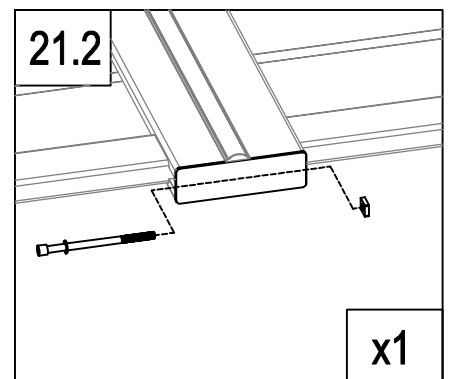
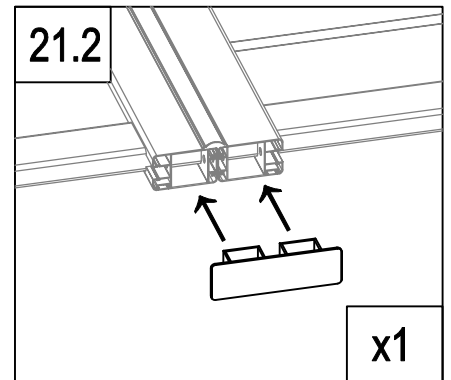
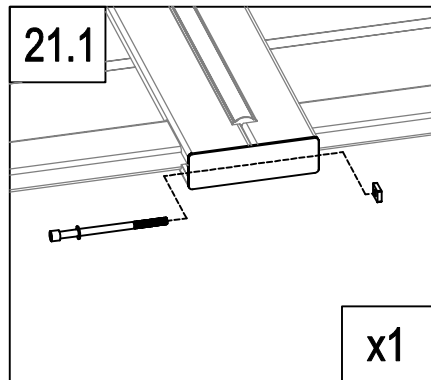
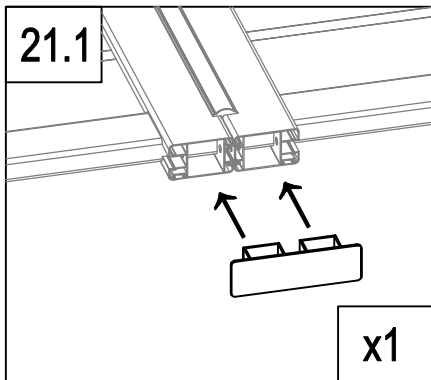
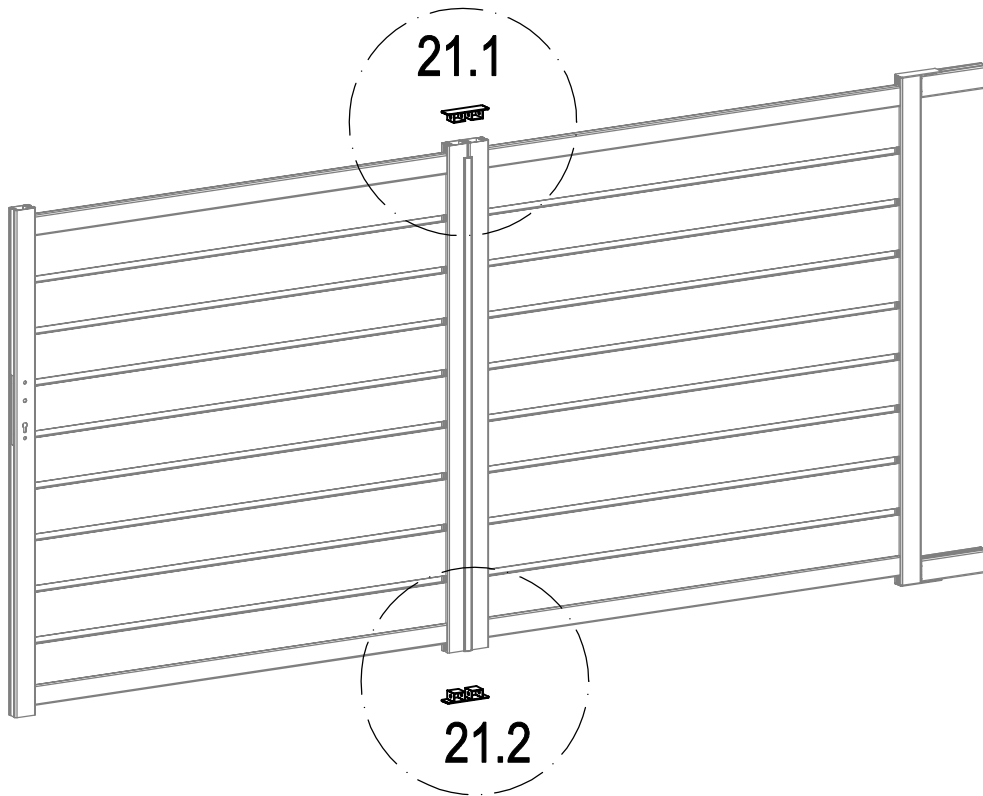

	AT-10	2
	VT-V30	2



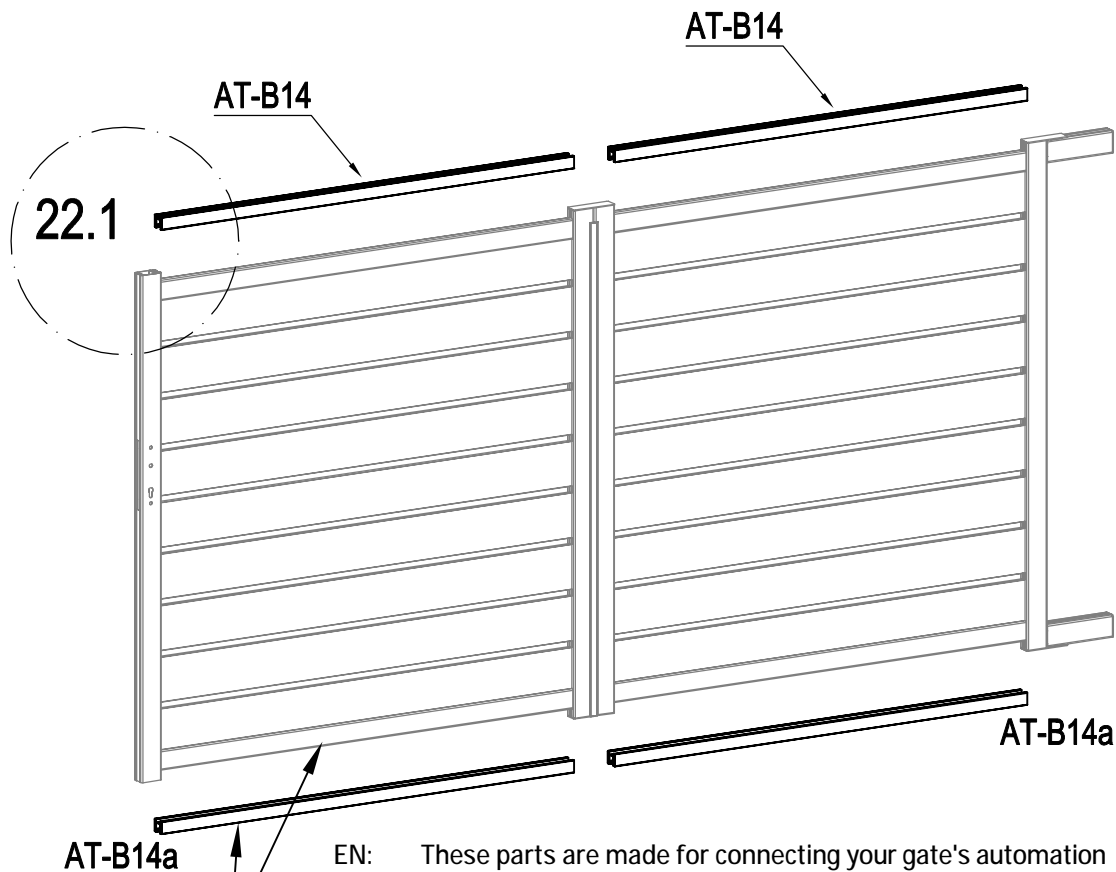

	AT-17	2
	VT-V33	2



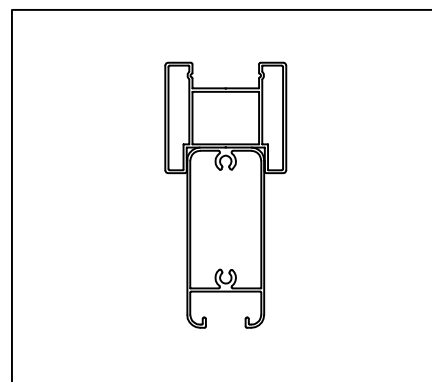
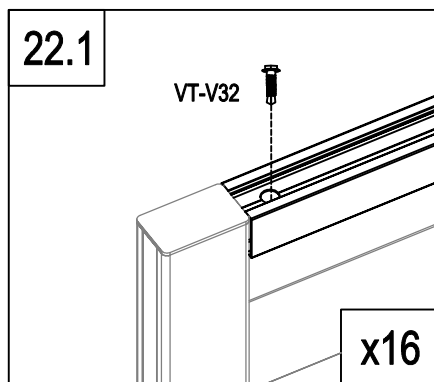
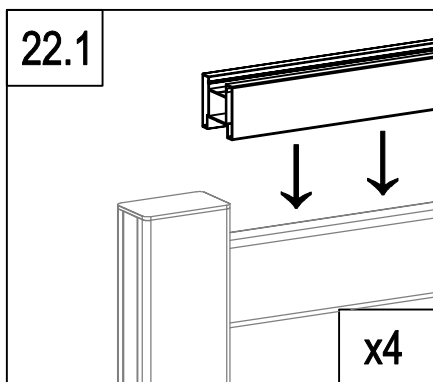

EN: These parts are made for connecting your gate's automation
 FR: Ces pièces sont faites pour relier l'automatisation de votre portail
 DE: Diese Teile sind für den Anschluss der Automatisierung Ihres Tores vorgesehen
 ES: Estas piezas están hechas para conectar la automatización de su puerta
 PT: Estas peças são feitas para ligar a automatização do seu portão
 IT: Queste parti sono realizzate per collegare l'automazione del vostro cancello
 NL: Deze onderdelen zijn gemaakt voor het aansluiten van de automatisering van uw poort.
 PL: Te części są wykonane do podłączenia automatyki bramy.



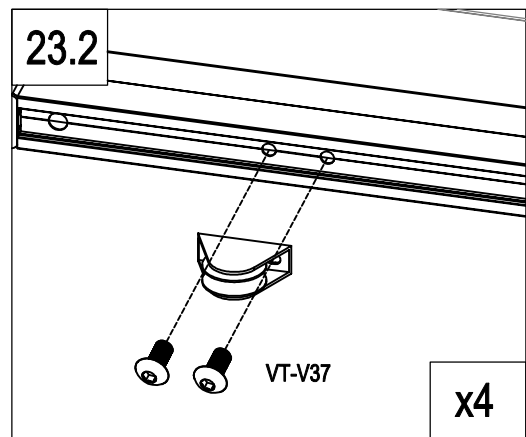
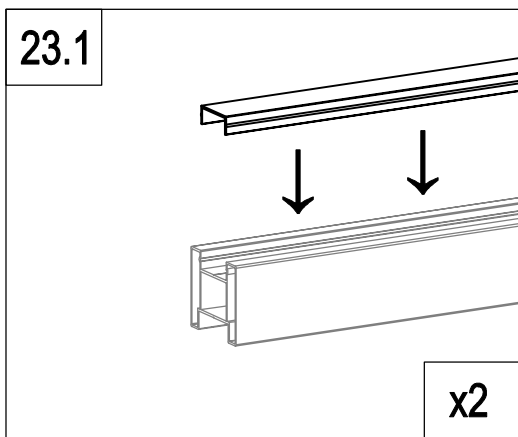
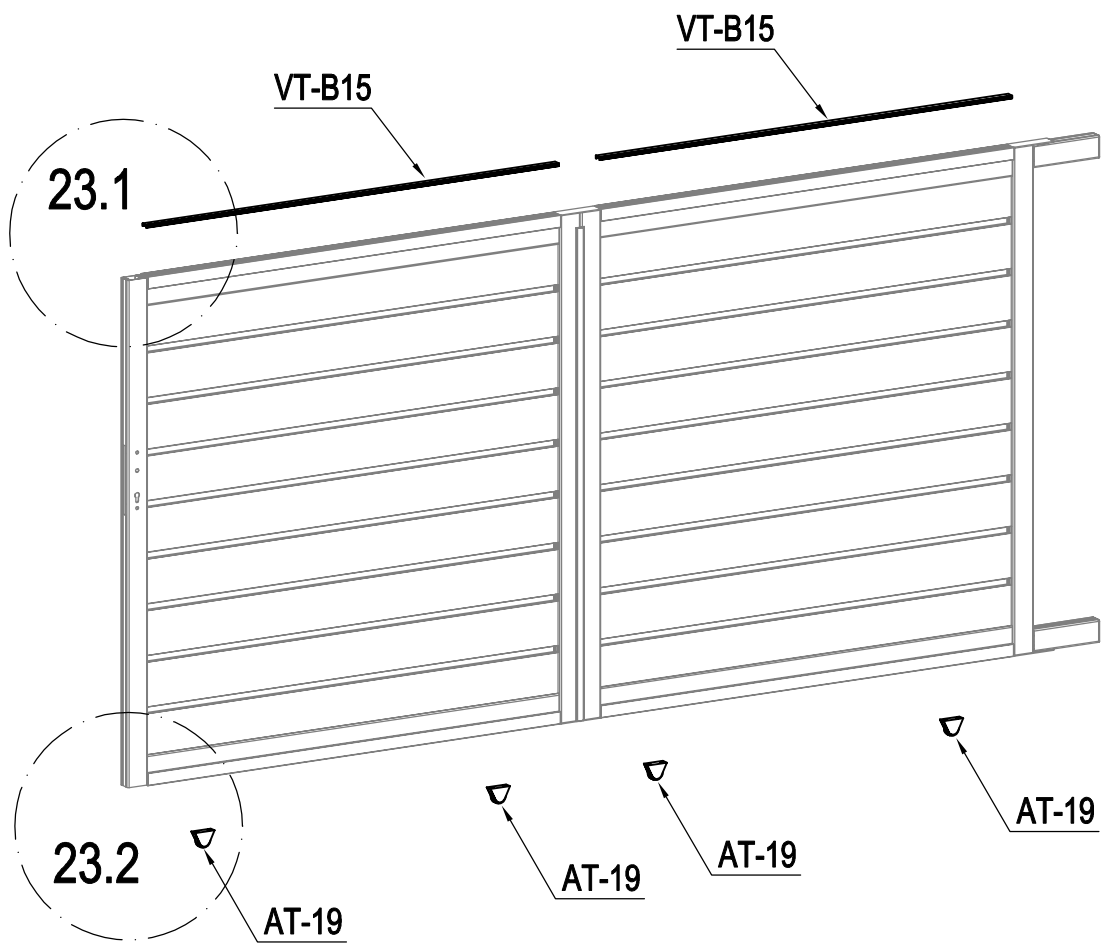

	AT-B14	2
	AT-B14a	2
	VT-V32	16

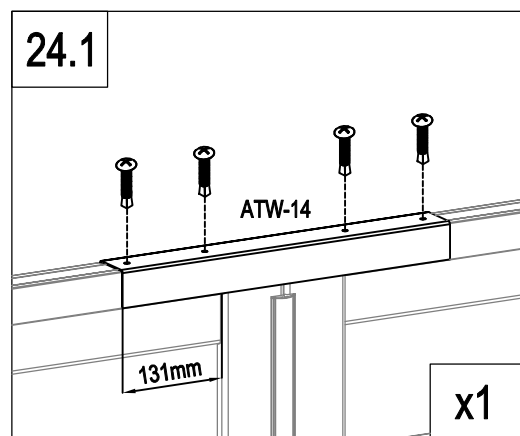
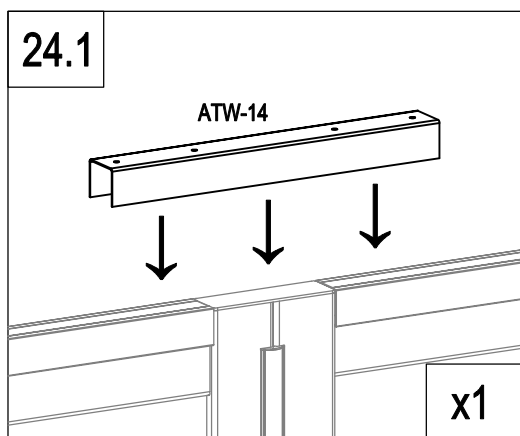
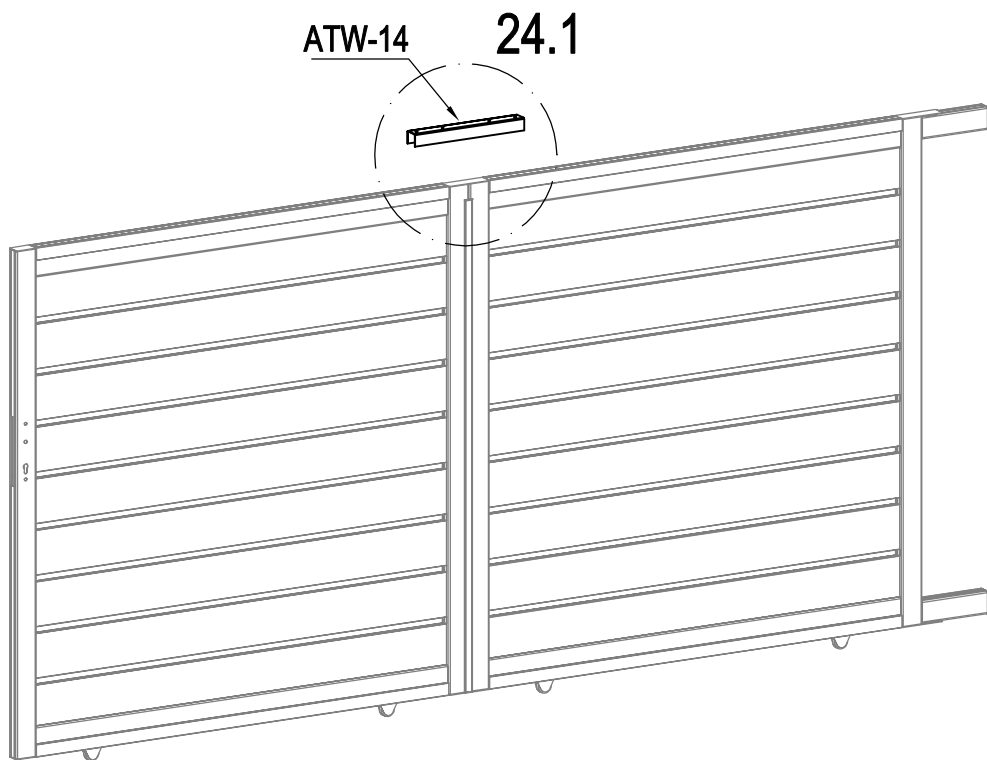

	VT-B15	2
	AT-19	4
	VT-V37	8



	ATW-14	1
	VT-V34	4

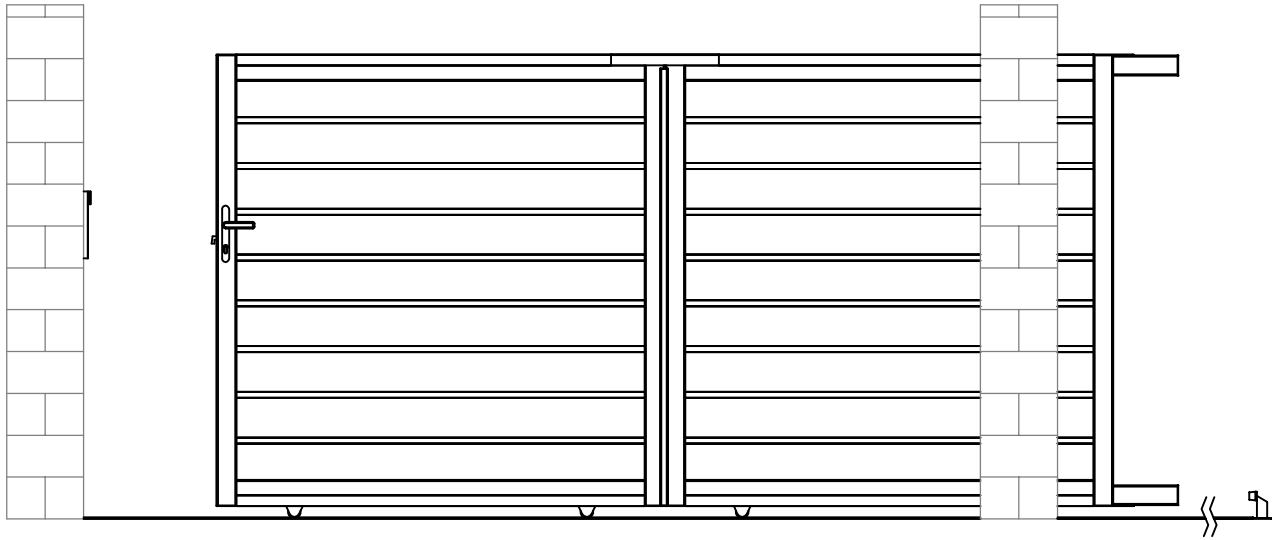

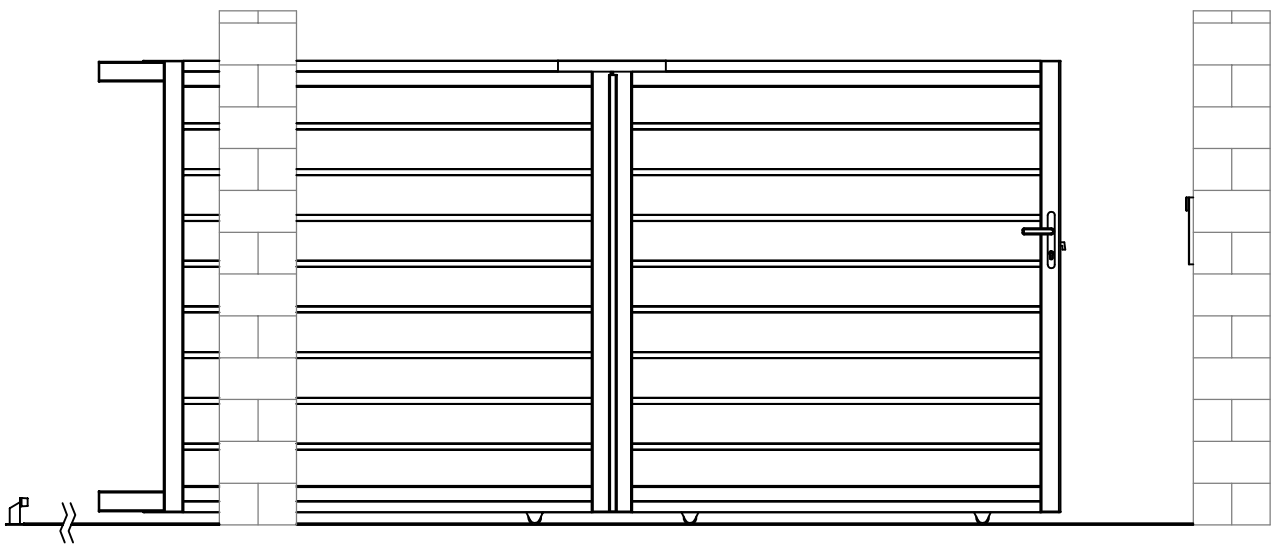

L : P25~30

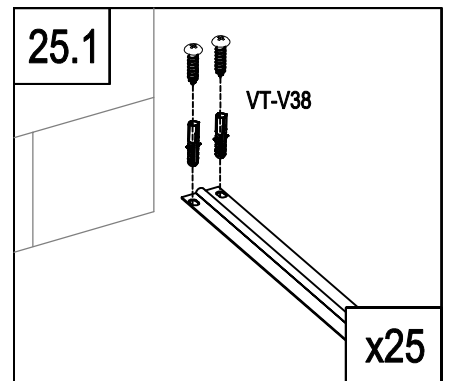
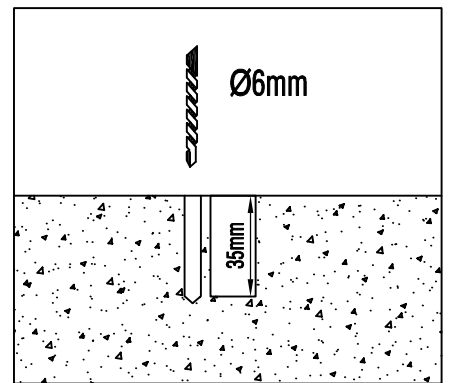
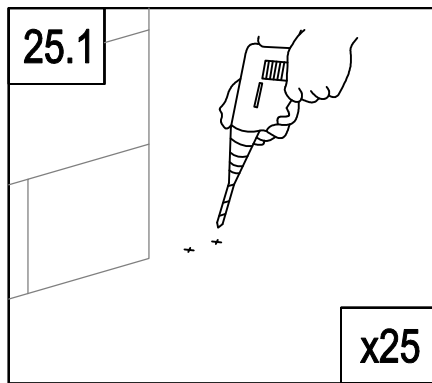
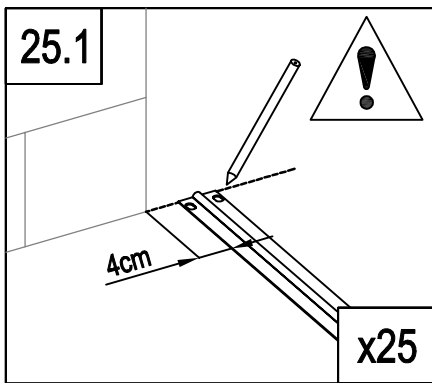
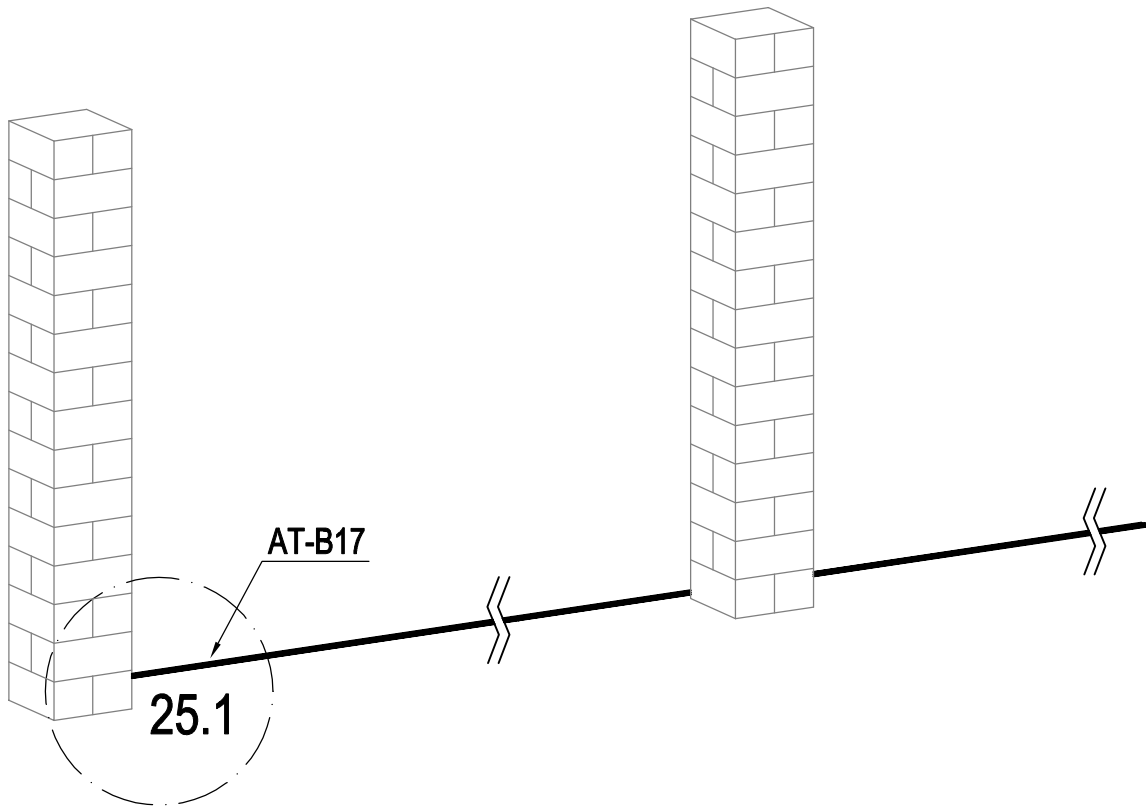

R : P31~36



	AT-B17	5
	VT-V38	50

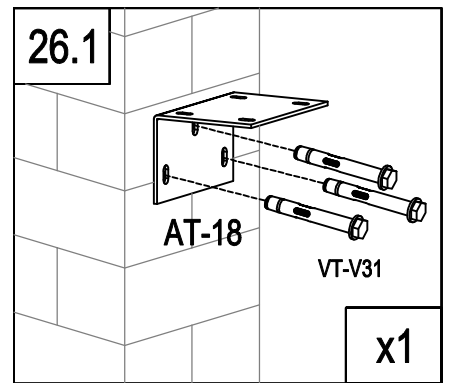
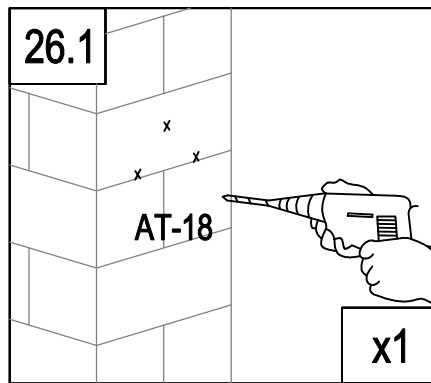
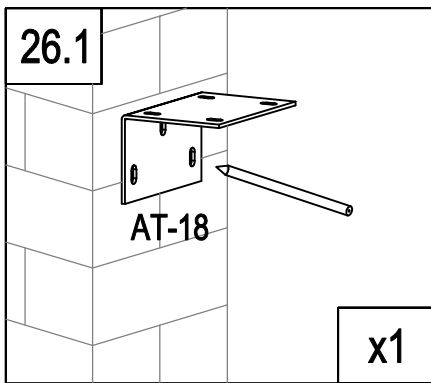
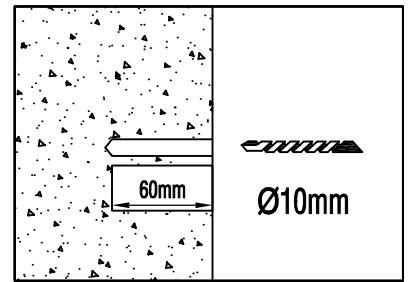
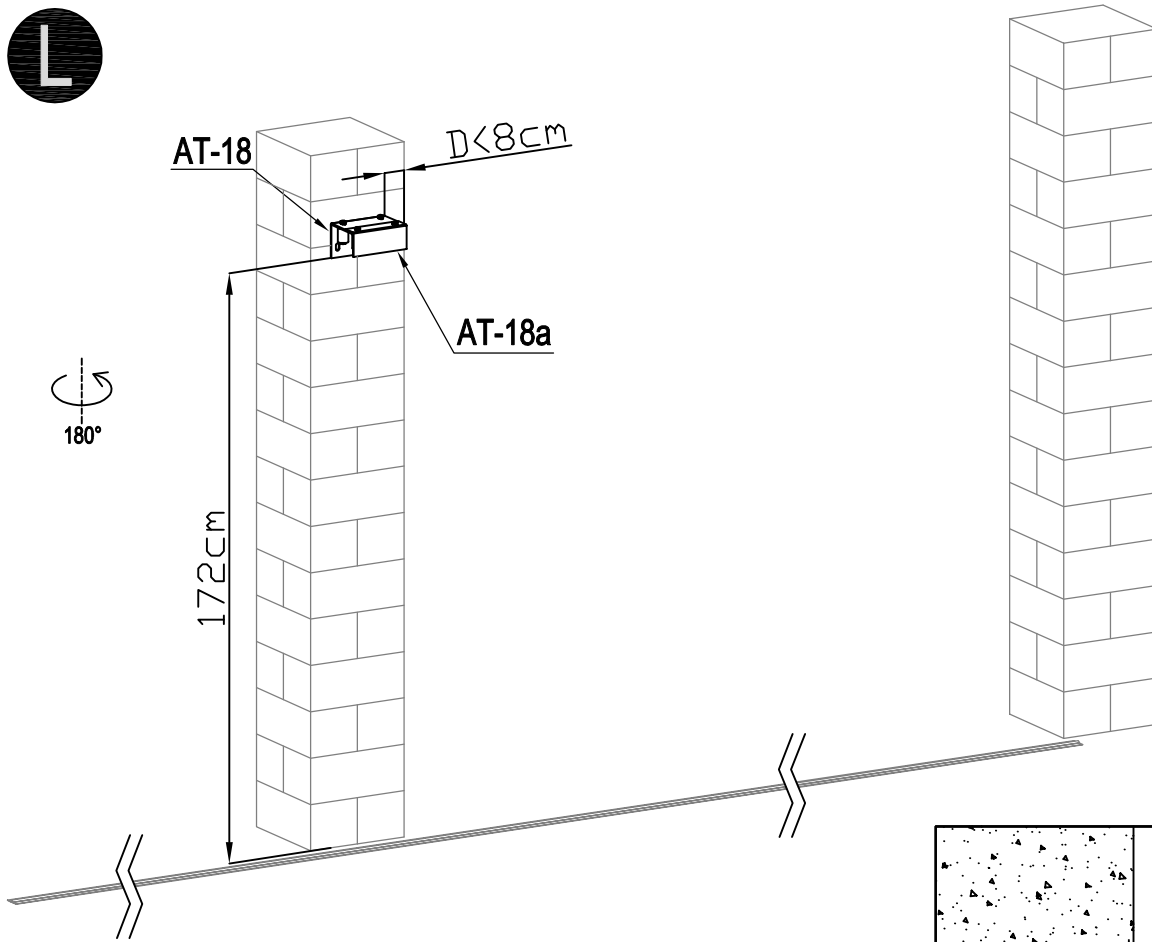

	AT-18	1
	AT-18a	1
	AT-20	4
	VT-V31	3

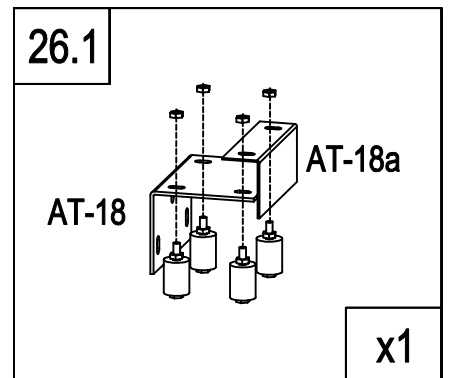
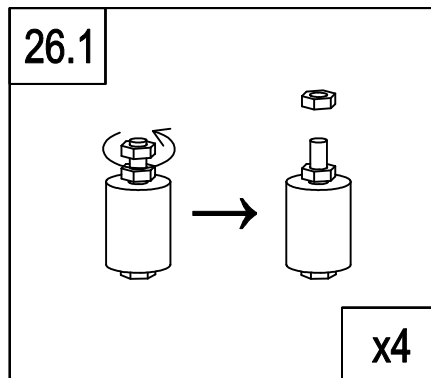

L

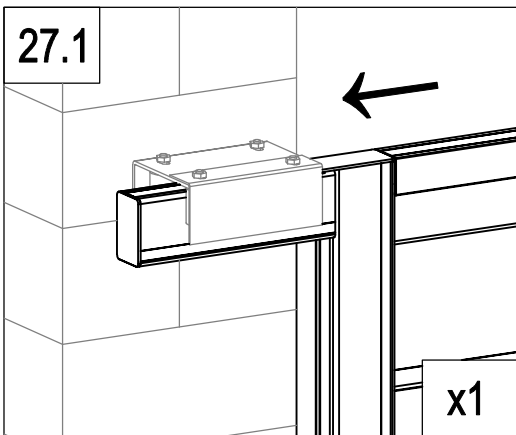
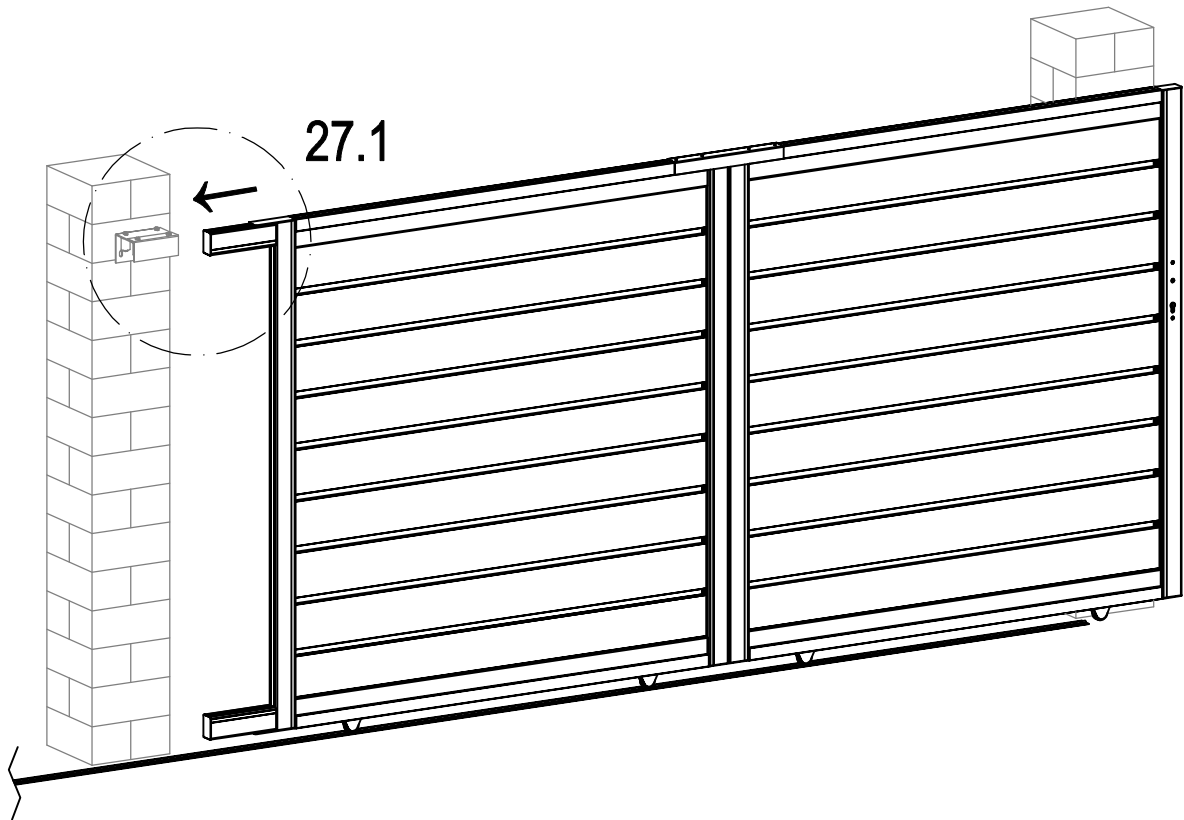

L

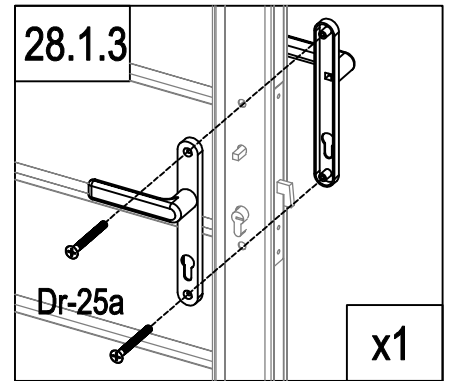
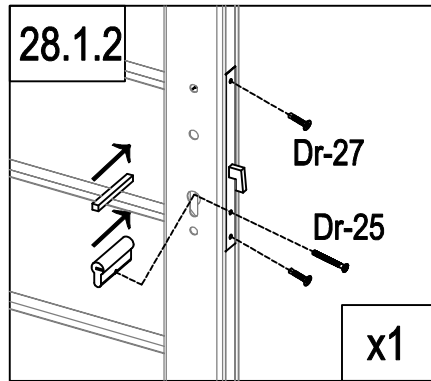
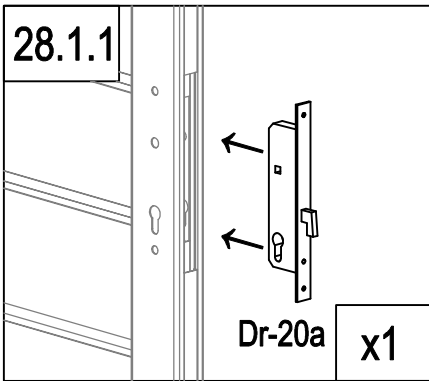
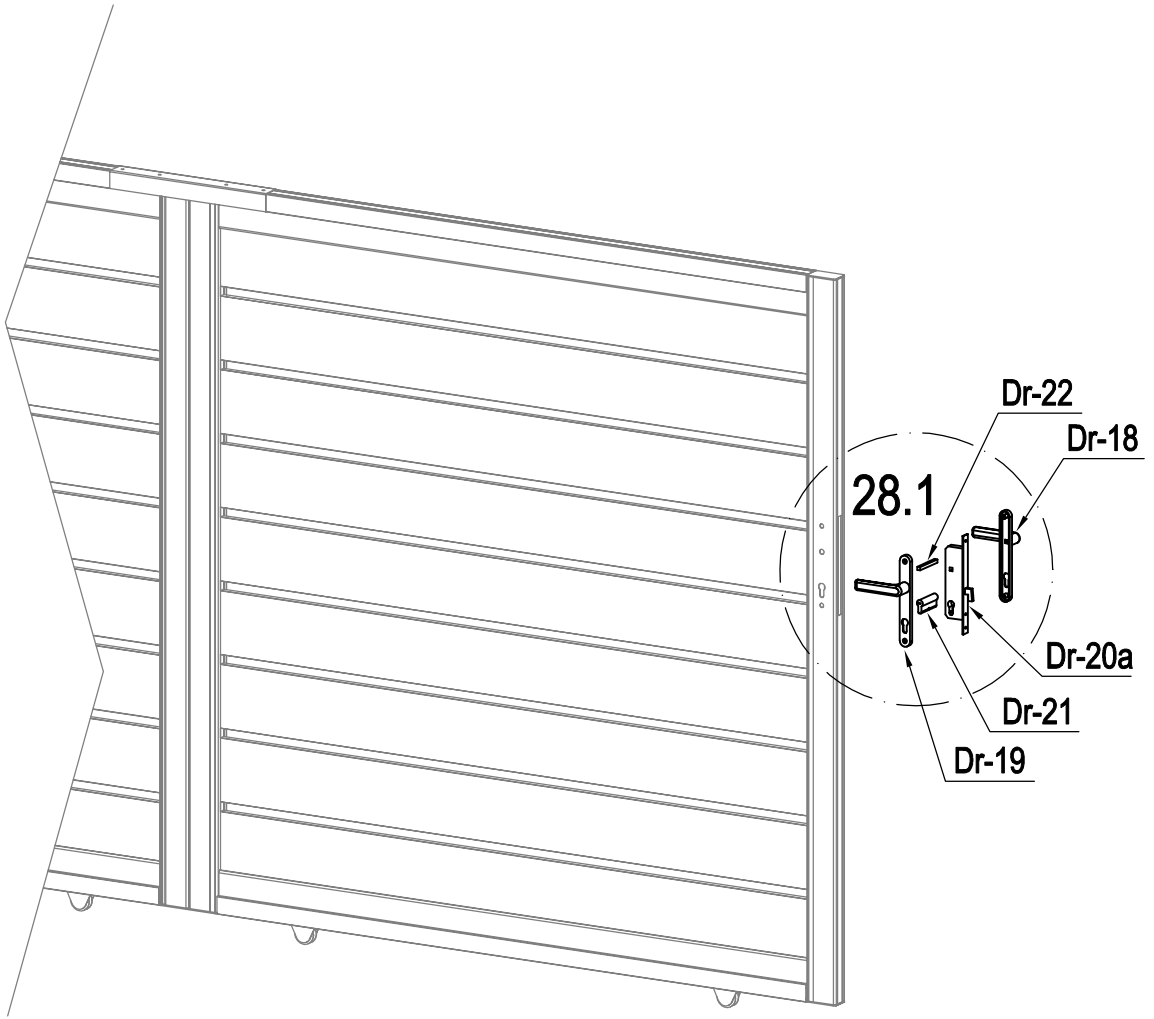

	Dr-20a	1
	Dr-21	1
	Dr-22	1
	Dr-25	1

	Dr-18	1
	Dr-19	1
	Dr-25a	2
	Dr-27	2

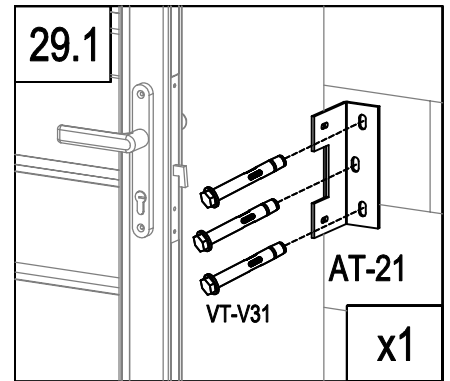
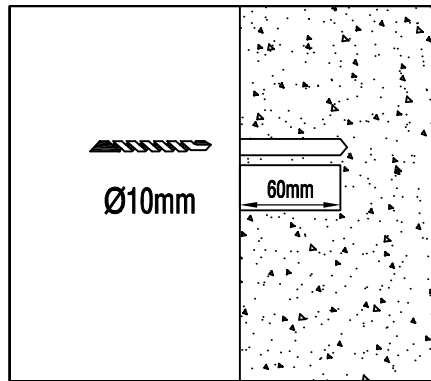
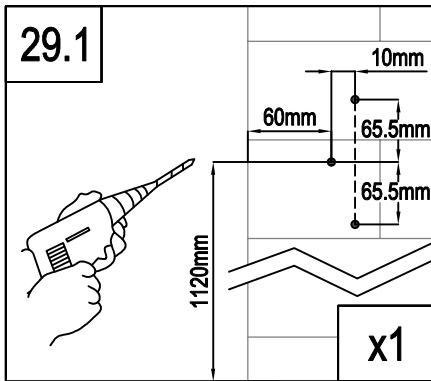
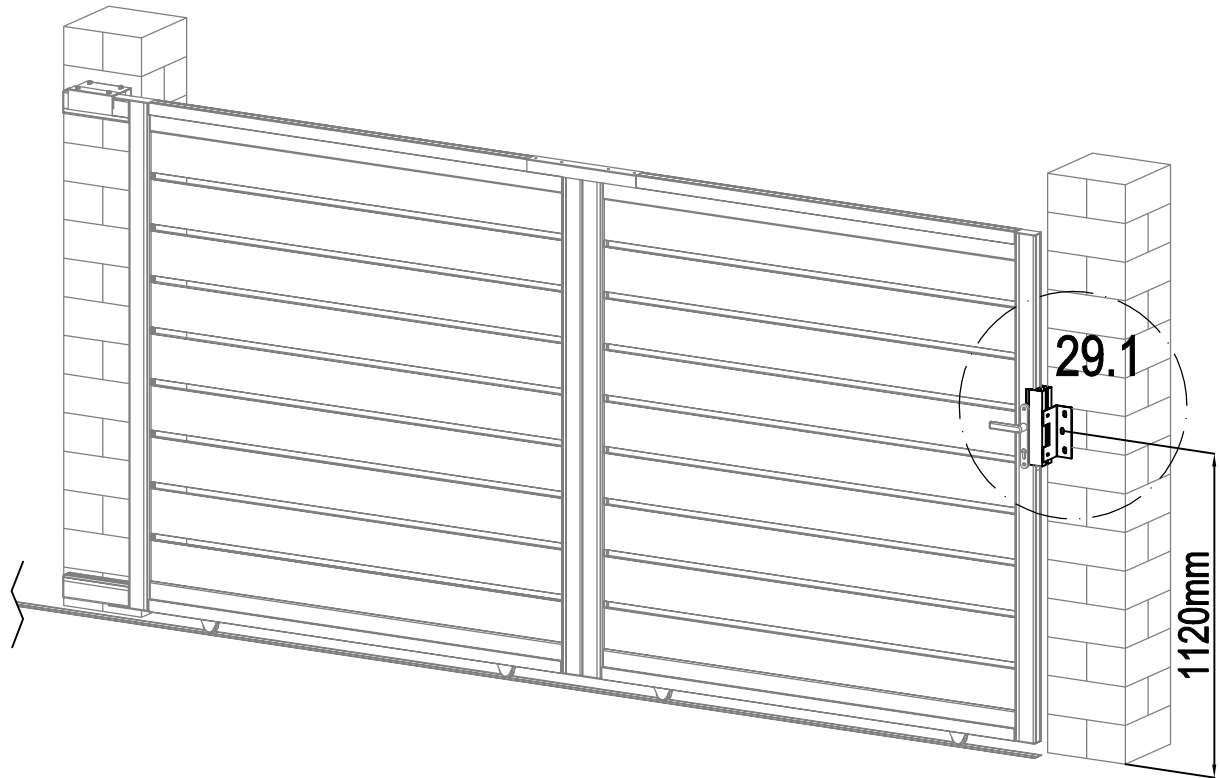

	AT-16	1
	AT-21	1
	VT-V36	2
	VT-V31	3
	AT-22J	3

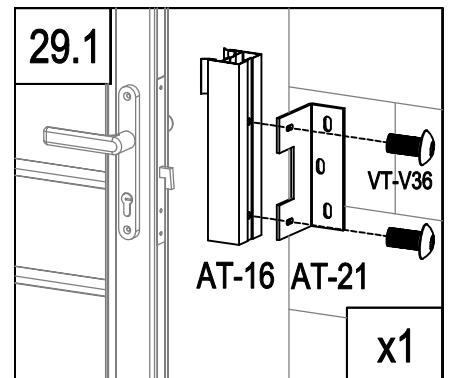
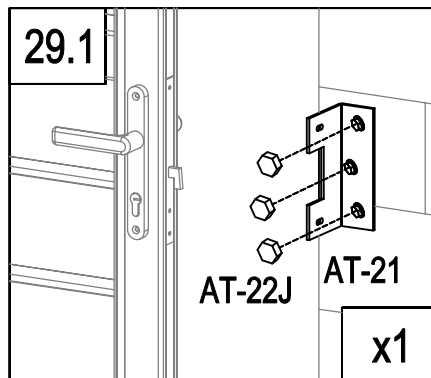

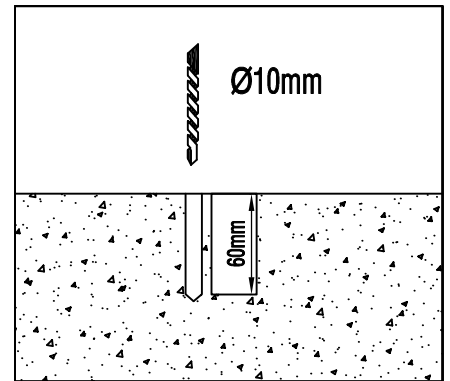
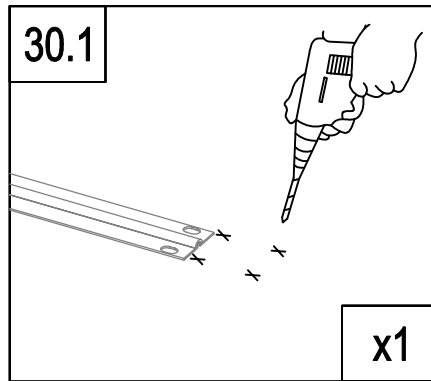
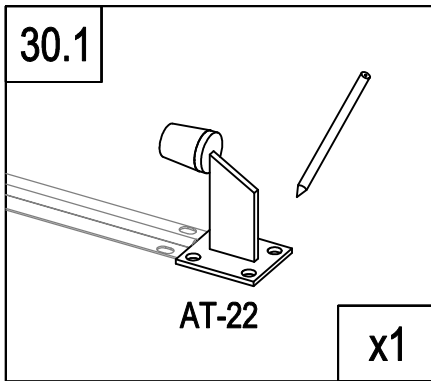
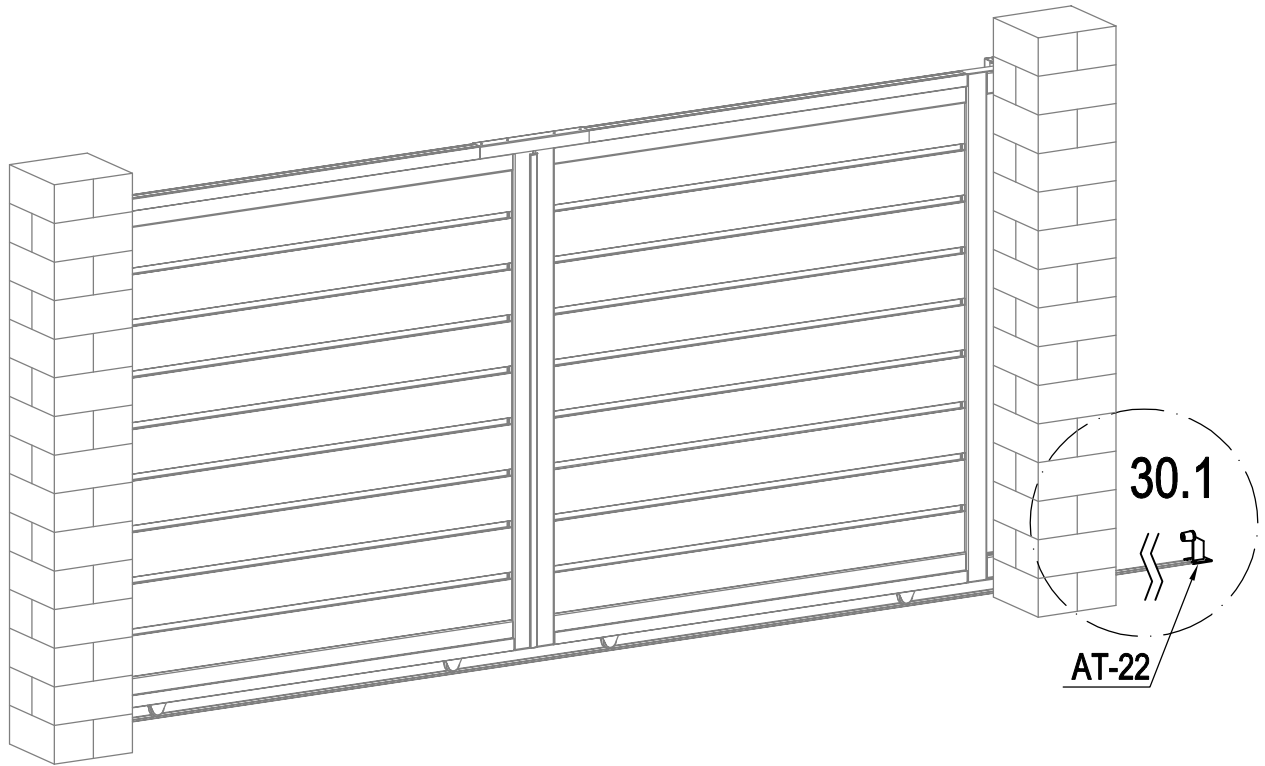

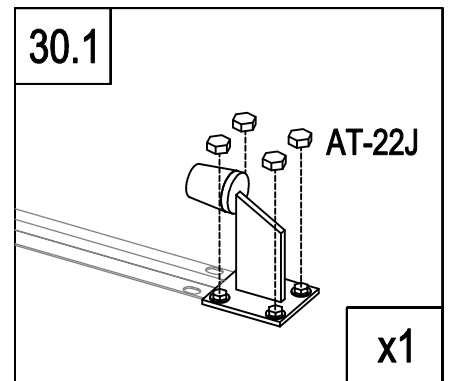
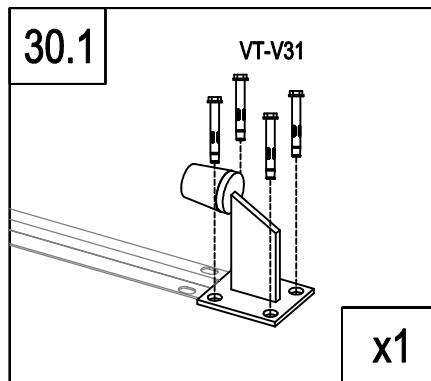

	AT-22	1
	VT-V31	4
	AT-22J	4

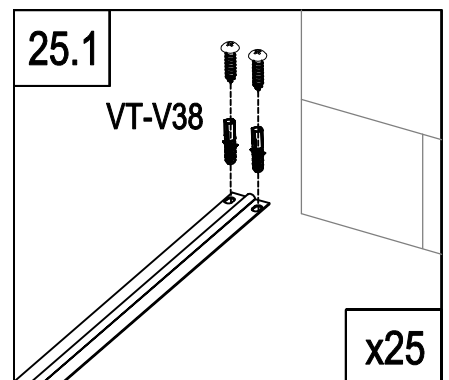
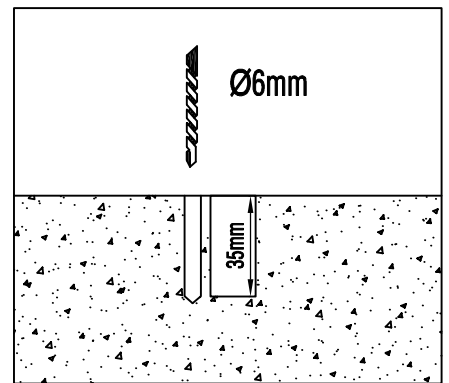
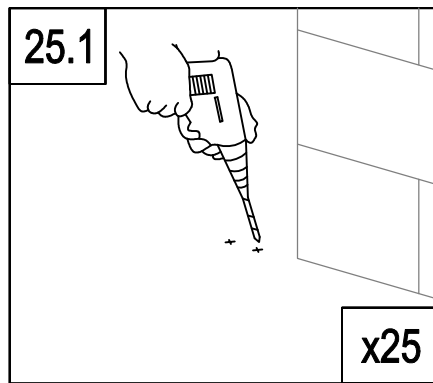
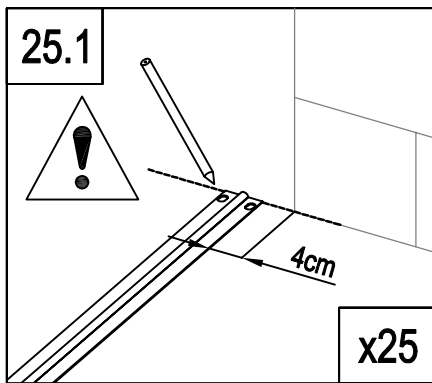
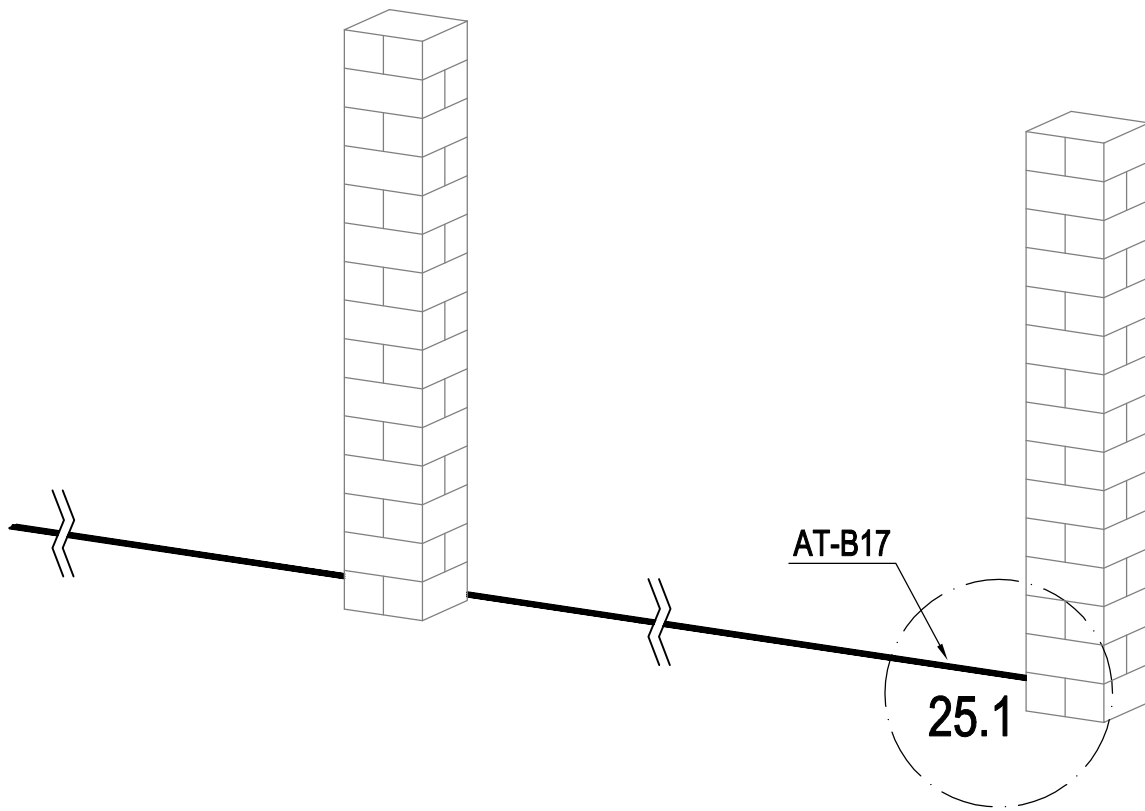



	AT-B17	5
	VT-V38	50

R

180°

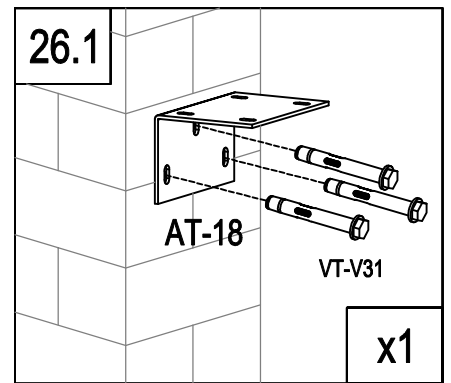
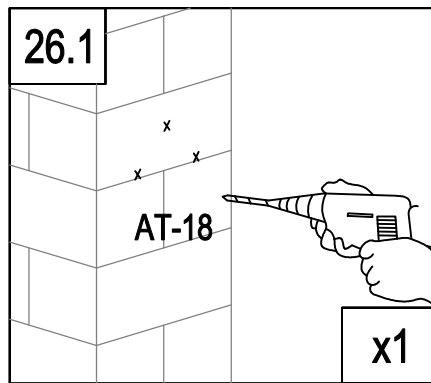
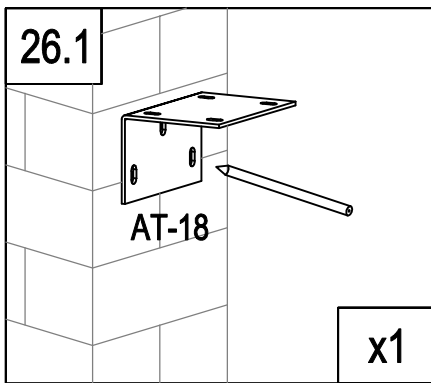
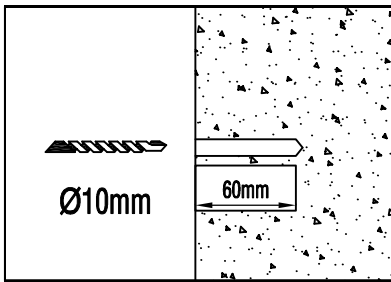
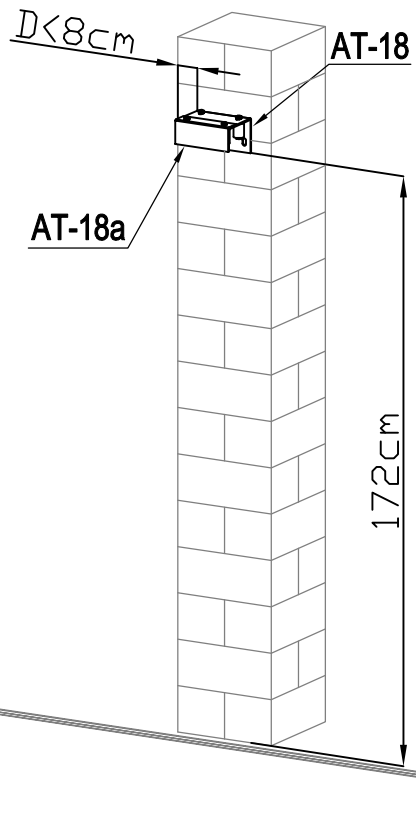
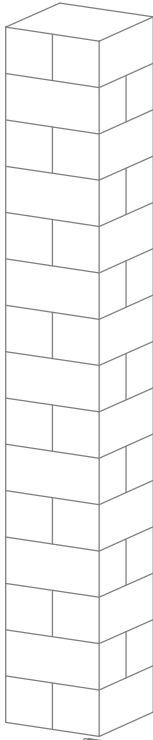

	AT-18	1
	AT-18a	1
	AT-20	4
	VT-V31	3

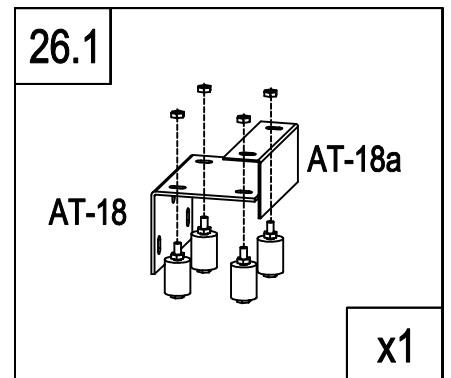
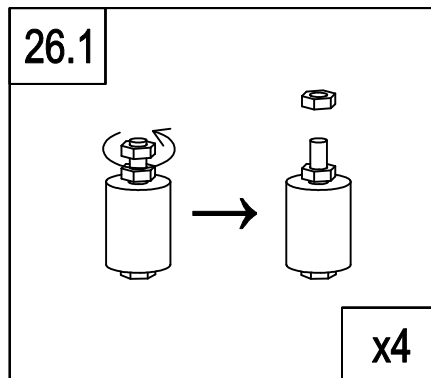

R

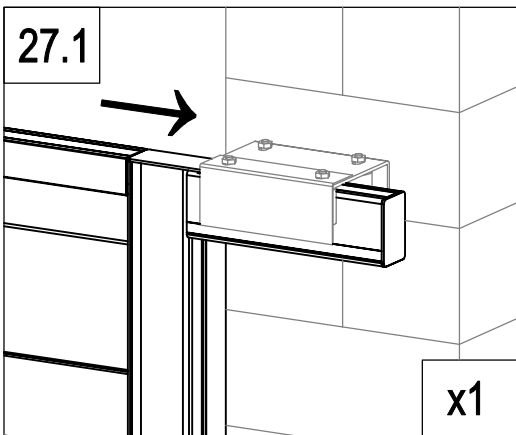
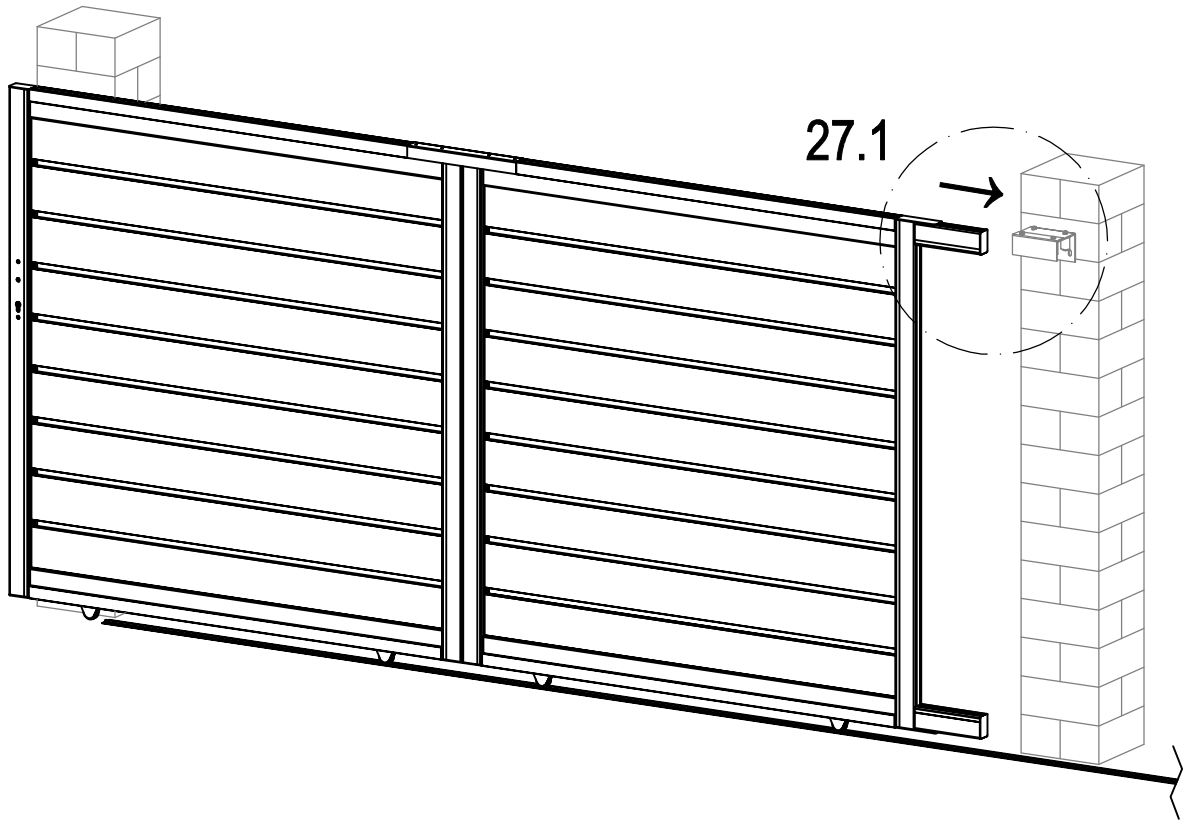

R

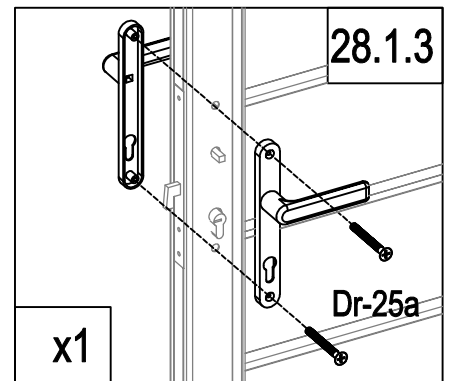
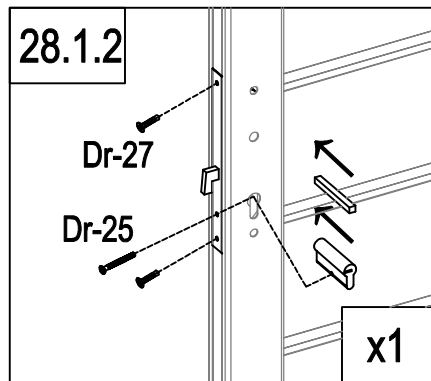
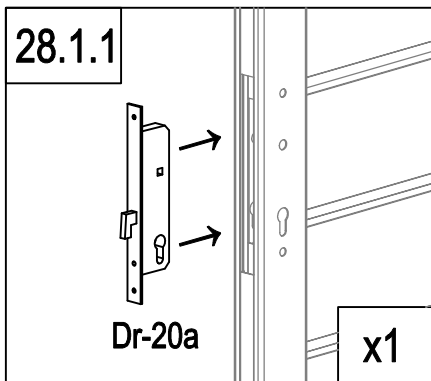
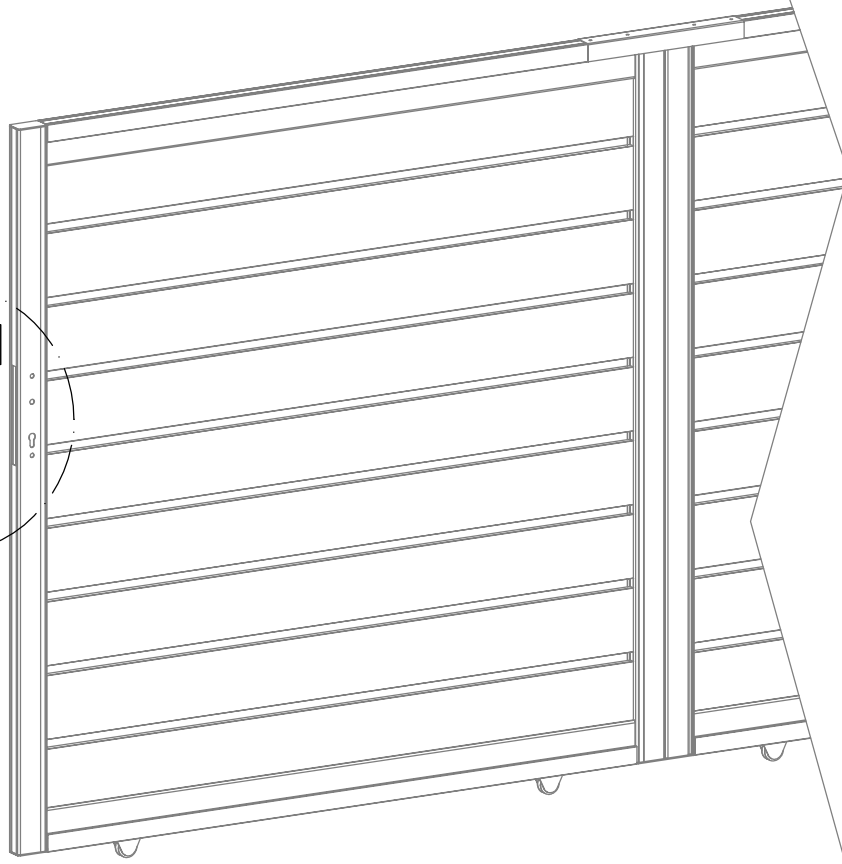
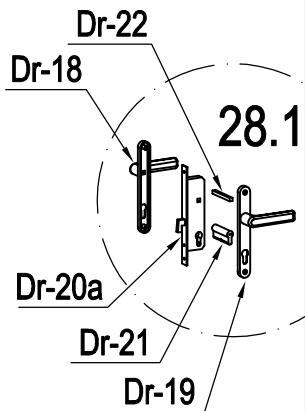

	Dr-20a	1
	Dr-21	1
	Dr-22	1
	Dr-25	1

	Dr-18	1
	Dr-19	1
	Dr-25a	2
	Dr-27	2

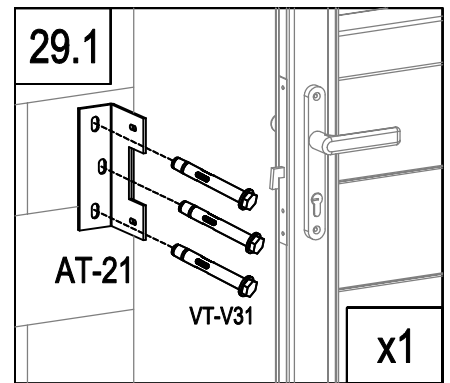
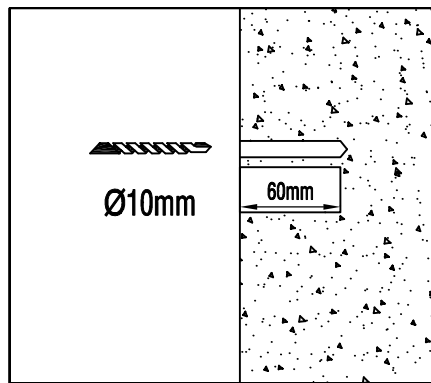
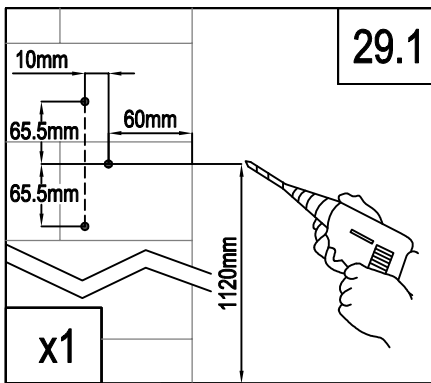
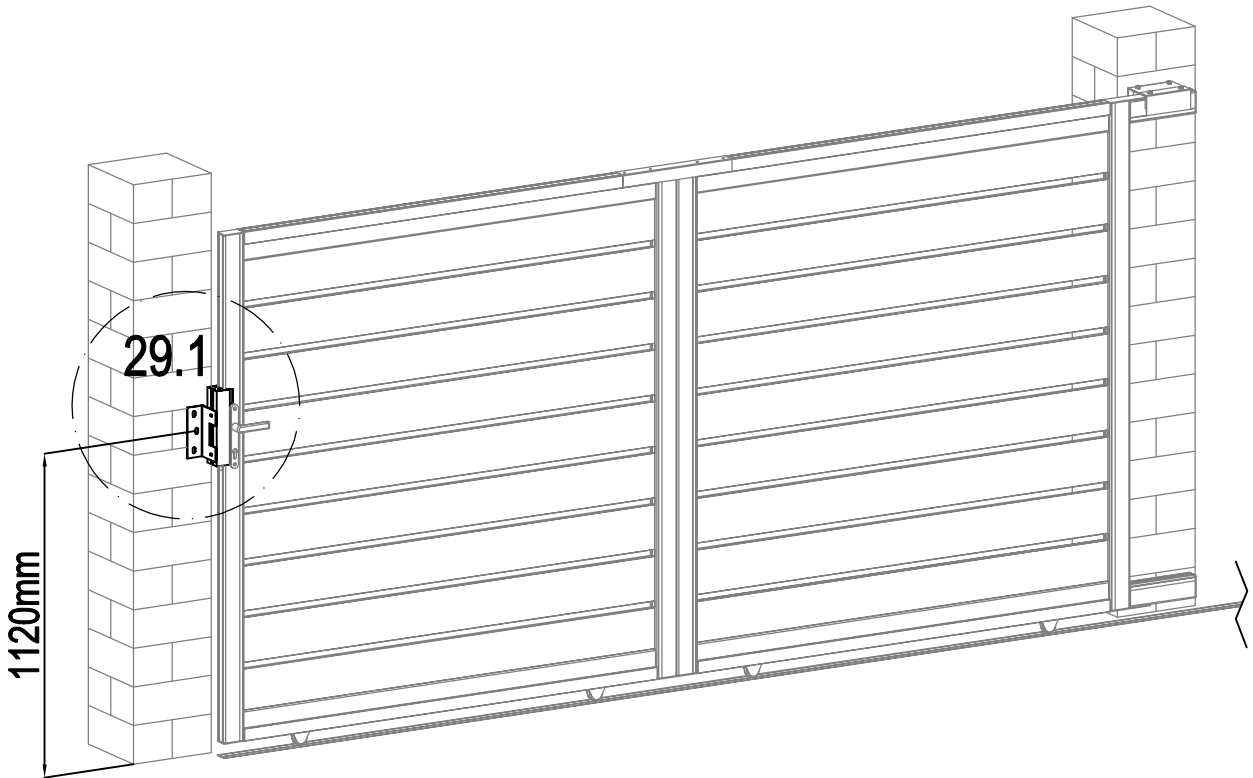

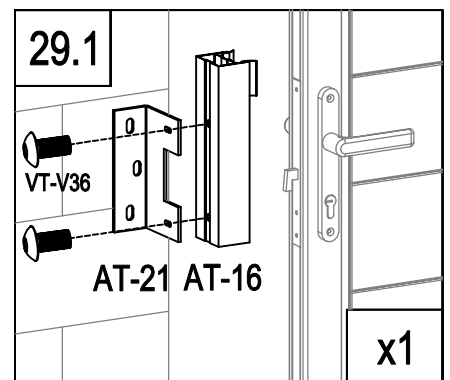
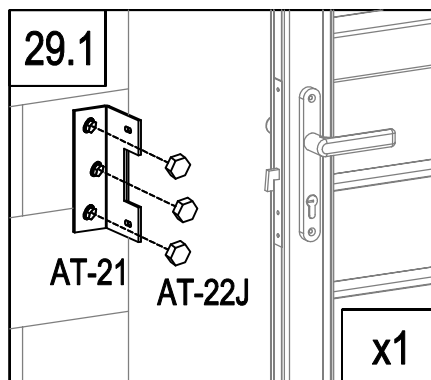

	AT-16	1
	AT-21	1
	VT-V36	2
	VT-V31	3
	AT-22J	3

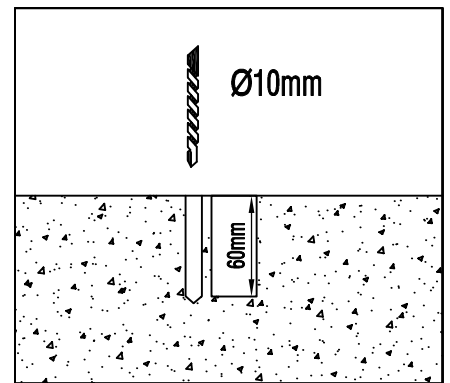
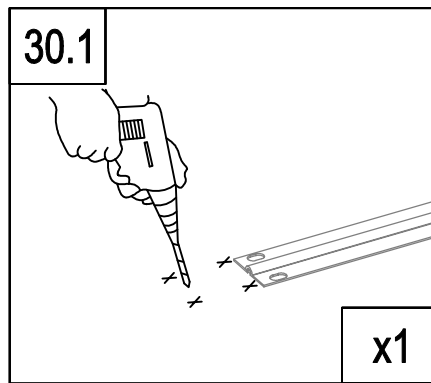
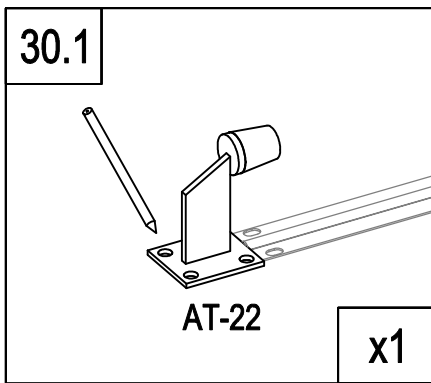
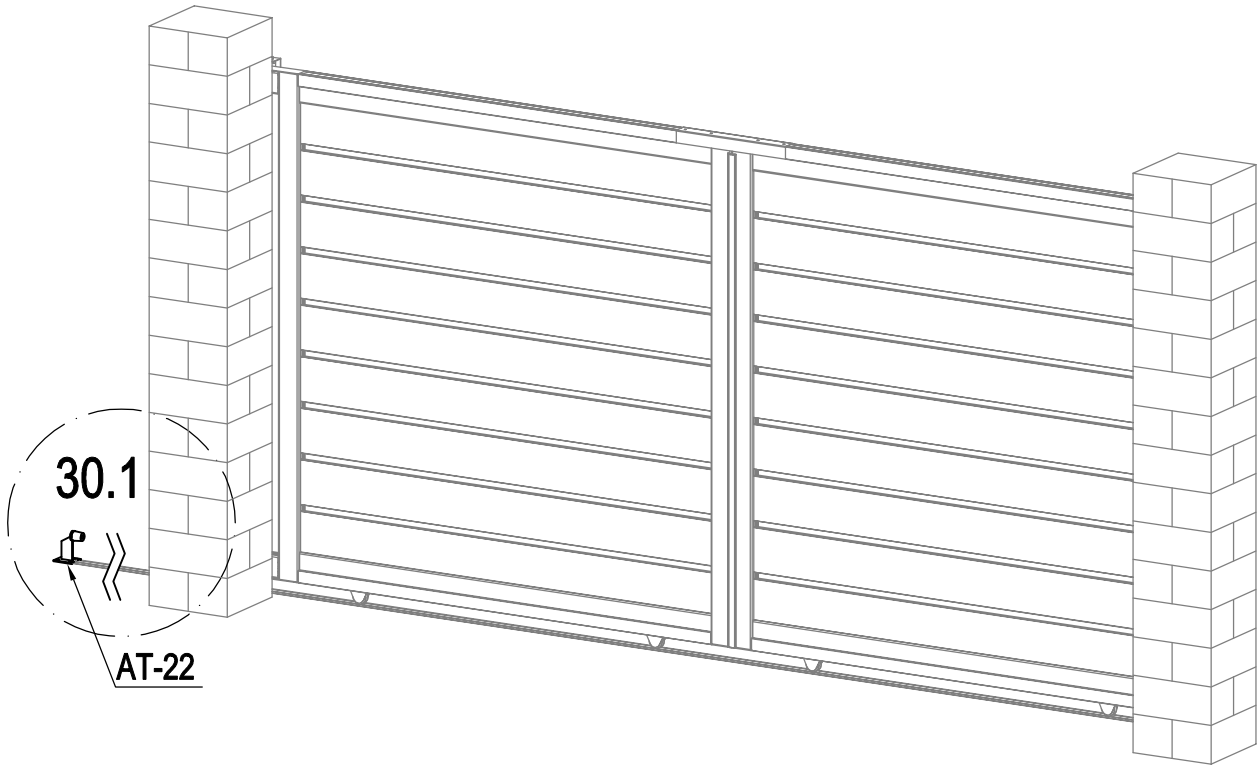

R



	AT-22	1
	VT-V31	4
	AT-22J	4

